

## Fenghua Technology Servo Precision Reducer Products



90 Degree Right Angle Gearbox

RV Reducer

Harmonic Reducer

Fenghua Transmission is committed to offering you quality products  
Specializing in R & D and production of  
various precision planetary gearboxes  
TEL: 400-8040-668

Click [www.3fgearbox.com](http://www.3fgearbox.com) for CAD, 3D, and 2D files of products



### Jiangsu Fenghua Transmission Technology Co.,Ltd.

Address: No.985 Jingwang Road, Development Zone,  
Kunshan City, Jiangsu Province  
Tel.: 0512-50167005 / 18117444109  
Email: [Info@3fgearbox.com](mailto:Info@3fgearbox.com)  
Website: [www.3fgearbox.com](http://www.3fgearbox.com)

### Guangdong Office

Add.: No.158 Zhen'an East Road, Chang'an Town,  
Dongguan City, Guangdong Province  
Tel.: 0755-23344659 Fax: 0755-23342973  
Mob.: 18928431587/18928431697/18038144705

### Jinan Office

Add.: Room 2004, Unit 1, Building 3, Lego International  
Building, Huayuan East Road, Lixia District, Jinan City  
Tel.: 0531-86956362 Fax: 0531-86956362  
Mob.: 15689738188

### Zhejiang Office

Add.: Room 413, Zhongqing Building, No. 75 Kangqiao Road,  
Gongshu District, Hangzhou City, Zhejiang Province  
Tel.: 0571-86699905 Fax: 0571-86699905

### Operation Center

### Fenghua Transmission Technology (Shanghai) Co.,Ltd.

Add.: No.4777 Minfeng Industrial Zone, Jiasong North  
Road, Jiading District, Shanghai  
Tel.:021-39948832 / 39948836 13701956498

### International Trading Department

Tel.: 0512-50167005 / 181 1744 4109  
Email: [Info@3fgearbox.com](mailto:Info@3fgearbox.com)  
Website: [www.3fgearbox.com](http://www.3fgearbox.com)

### Tianjin Office

Add.: No. 118, Inc. 1, Building 6, Block 2, Hardware City,  
Miyun Road, Nankai District, Tianjin City  
Tel.: 022-87809695 Fax: 022-87809695  
Mob.: 15620987332

### Fujian Office

Add.: No.50 Tianying Yiwo, Jimei North Industrial Zone,  
Xiamen City, Fujian Province  
Tel.: 0592-6066458 Fax: 0592-6066432

3F FAMED

Fenghua Transmission Technology (Shanghai) Co.,Ltd.



For stepper / servo motor

# Planetary Gearbox

Taiwan excellent technology/precision transmission solutions expert



Jiangsu Fenghua Transmission Technology Co.,Ltd.

Jiangsu Fenghua Transmission Technology Co.,Ltd.

2023

# 3F FAMED<sup>®</sup> Company Introduction

Fenghua Transmission Technology Co.,Ltd. is developed from a factory which professionally manufactures the gears. All staffs of factory and R & D team have more than 20 years' gear manufacturing and designing experience. The factory cooperated with professional planetary gearbox technology team in the early period, and then established business department of the planetary gearbox series. The servo exclusive-used precision gearbox series the company produced are with three features of low backlash (5~8 arcmin), low noise (60dAB) and high efficiency ( $\geq 95\%$ ). Products can be compatible with servo motors and stepper motors produced by any servo factory. High precision planetary reducers features of reducing rotating speed, increasing torque greatly, increasing inertia of the motor rotor, improving rigidity, shortening the locating time of start and stop, miniaturizing the motor power and improving the stability of the inertia load and reducing the vibration at the same time.

In order to upgrade products, and adapt to the applicable range of high precision grade products, the factory launched the whole series of high precision helical planetary gearbox in late stage. With ultra-low backlash (1-3 arcmin) precision grade, the newly developed products can directly replace the sizes of the products produced by Germany and Japan. All product series are completed, and sizes and precision can perfectly match with that of Japanese and Germany. While upgrading planetary reducer products, the factory insists on the concept of R&D as the development direction of the company. Then the factory successively developed and launched 90 degree precision right angle gearboxes which are suitable for automation with different installation and output requirements, multi-joint robot industry reducers (RV high precision pin-wheel reducers), and harmonic reducers making use of the principle of the wave gear device invented by American genius inventor C. W. Musser, and precision gear & rack products. The factory can also customize the reducer. The products are widely used in tool machines (Planning Machine Tools), laser cutting machines, woodworking engraving machines, 3C automation, photovoltaic equipment, lithium battery and other fields of new energy equipment. And Fenghua gearboxes can also be found in fully servo paper towel machines, precision concave-convex printing machines, precision coating machines, servo pipe benders, CNC spring machines and other highly automated equipment.

The company matches a large stocks of products to coordinate with servo motor manufacturers and system integration traders, rooting in the domestic market, and determined to serve the domestic automatic industry and robotic field by excellent products and serve for the Chinese robot cause and Industrial 4.0 direction.



## Production workshop



# Comprehensive catalogue

## Planetary reducer series

**VRB** High Precision Planetary Gearbox **VRB series**  **06-09**

**EVB** High Precision Right Angle Planetary Gearbox **EVB series**  **10-13**

**VRL** High Precision Planetary Gearbox **VRL series**  **14-17**

**EVL** High Precision Right Angle Planetary Gearbox **EVL series**  **18-21**

**VRT** High Precision Flange Output Planetary Gearbox **VRT series**  **22-26**

**EVT** High Precision Flange Output Right Angle Planetary Gearbox **EVT series**  **27-31**

**VRS** European High Precision High Torque Planetary Gearbox **VRS series**  **32-35**

**EVS** European High Precision High Torque Right Angle Planetary Gearbox **EVS series**  **36-39**

**PAB** High Precision High Torque Planetary Gearbox **PAB series**  **40-43**

**PAR** High Precision High Torque Right Angle Planetary Gearbox **PAR series**  **44-47**

**VRSF** Precision Planetary Gearbox **VRSF series**  **48-51**

## Servo reducer series

**FB** Precision Planetary Gearbox **FB series**  **52-55**

**FBR** Precision Right Angle Planetary Gearbox **FBR series**  **56-59**

**FE** Precision Planetary Gearbox **FE series**  **60-63**

**FER** Precision Right Angle Planetary Gearbox **FER series**  **64-67**

**PLF** Standard Type Planetary Gearbox **PLF series**  **68-71**

**PFR** Standard Type Right Angle Planetary Gearbox **PFR series**  **72-75**

**PLE** Standard Type Planetary Gearbox **PLE series**  **76-79**

**PER** Standard Type Right Angle Planetary Gearbox **PER series**  **80-83**

**ZR/RM** Precision Right Angle Gearbox **ZR/RT series**  **84-94**

**ZK/DG** Precision Hollow Rotary Actuator **ZK/DG series**  **95-120**

**DK** DK Series Heavy duty rotating platform **DK series**  **121-125**

# Product Application Industry

Semiconductor liquid crystal manufacturing equipment, robots, machine tools, and other frontier areas requiring precision motion control are widely used.

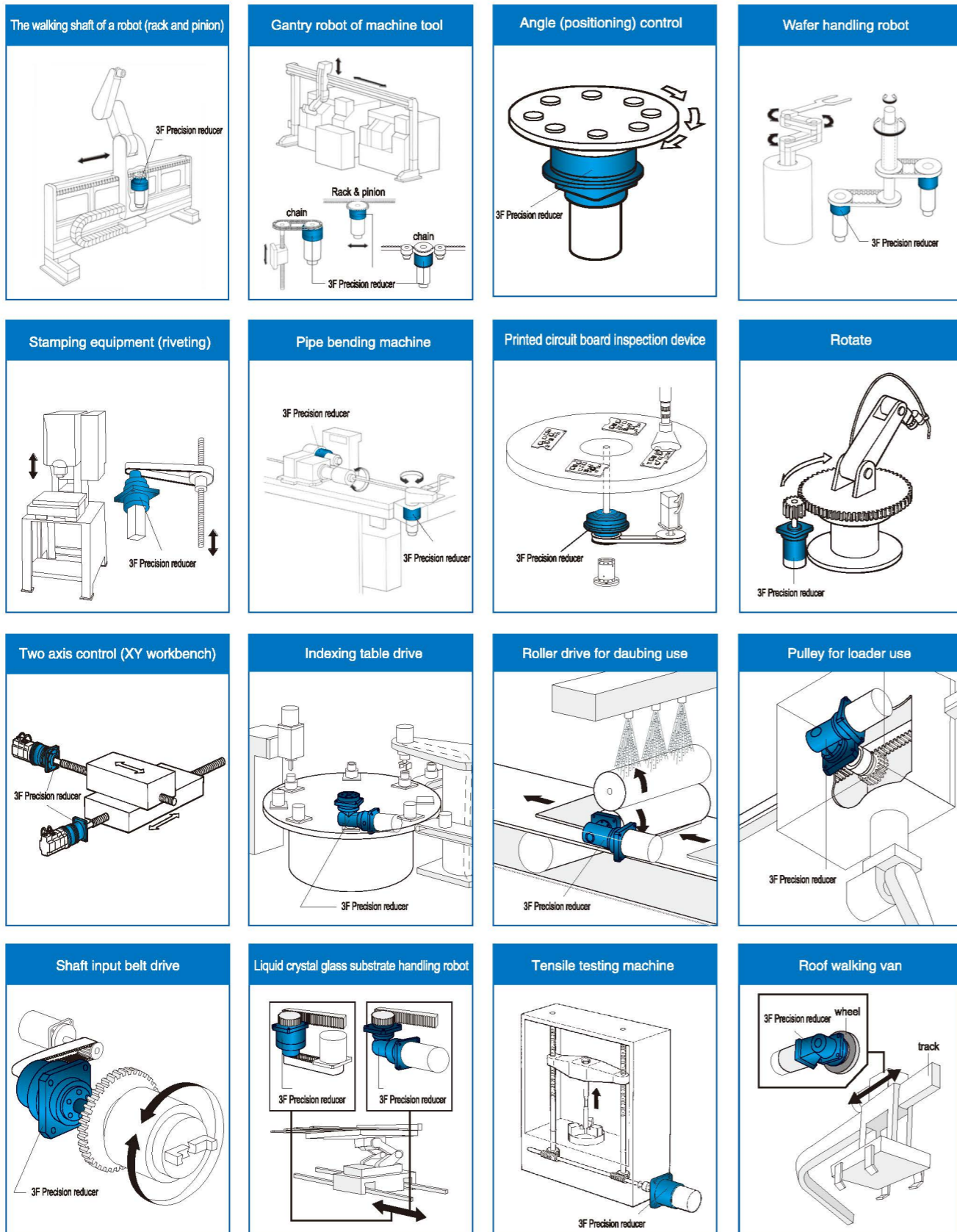

# Reference Table of Reducer Selection

Selecting reducer according to the output power of servo motor

Capacity	Model	1/3	1/4	1/5	1/7	1/10	1/12	1/15	1/16	1/20	1/25	1/28	1/30	1/35	1/40	1/50	1/70	1/100
100w	042	•	•	•	•	•	•	•	•	•	•	•	•	•	•			
	060	•	•	•	•	•	•	•	•	•	•	•	•	•	•	•	•	•
200w	060	•	•	•	•	•	•	•	•	•	•	•	•	•	•	•	•	•
	090	•	•	•	•	•	•	•	•	•	•	•	•	•	•	•	•	•
400w	060	•	•	•	•	•	•	•	•	•	•	•	•	•	•	•	•	•
	090	•	•	•	•	•	•	•	•	•	•	•	•	•	•	•	•	•
500w	090	•	•	•	•	•	•	•	•	•	•	•	•	•	•	•	•	•
	120	•	•	•	•	•	•	•	•	•	•	•	•	•	•	•	•	•
750w	090	•	•	•	•	•	•	•	•	•	•	•	•	•	•	•	•	•
	120	•	•	•	•	•	•	•	•	•	•	•	•	•	•	•	•	•
1.0kw	090	•	•	•	•	•	•	•	•	•	•	•	•	•	•	•	•	•
	120	•	•	•	•	•	•	•	•	•	•	•	•	•	•	•	•	•
1.5kw	150	•	•	•	•	•	•	•	•	•	•	•	•	•	•	•	•	•
	090	•	•	•	•	•	•	•	•	•	•	•	•	•	•	•	•	•
2.0kw	120	•	•	•	•	•	•	•	•	•	•	•	•	•	•	•	•	•
	150	•	•	•	•	•	•	•	•	•	•	•	•	•	•	•	•	•
2.0kw	180	•	•	•	•	•	•	•	•	•	•	•	•	•	•	•	•	•
	120	•	•	•	•	•	•	•	•	•	•	•	•	•	•	•	•	•
3.5kw	150	•	•	•	•	•	•	•	•	•	•	•	•	•	•	•	•	•
	180	•	•	•	•	•	•	•	•	•	•	•	•	•	•	•	•	•
3.5kw	220	•	•	•	•	•	•	•	•	•	•	•	•	•	•	•	•	•
	120	•	•	•	•	•	•	•	•	•	•	•	•	•	•	•	•	•
5.0kw	150	•	•	•	•	•	•	•	•	•	•	•	•	•	•	•	•	•
	180	•	•	•	•	•	•	•	•	•	•	•	•	•	•	•	•	•
5.0kw	220	•	•	•	•	•	•	•	•	•	•	•	•	•	•	•	•	•
	180	•	•	•	•	•	•	•	•	•	•	•	•	•	•	•	•	•
7.0kw	220	•	•	•	•	•	•	•	•	•	•	•	•	•	•	•	•	•
	180	•	•	•	•	•	•	•	•	•	•	•	•	•	•	•	•	•
11.0kw	220	•	•	•	•	•	•	•	•	•	•	•	•	•	•	•	•	•
	180	•	•	•	•	•	•	•	•	•	•	•	•	•	•	•	•	•
15.0kw	220	•	•	•	•	•	•	•	•	•	•	•	•	•	•	•	•	•

P.S : This mark "•" means available reduction ratio.

Note 1: Three-stage speed reduction ratios are not available in the above stable. If needed, pls inform our sales person.

Note 2: Choose a bigger level of reducer to use when the inertia is bigger.

# Product Technology

The 3F series planetary gearbox has two multi-national patent lubricating structure, which is used in the internal spiral gear structure to ensure the highest efficient output.

Patent 1: Reducing the axial thrust of the planetary gear operation.

Patent 2: Increase the lubrication, reduce the frictional resistance and noise.

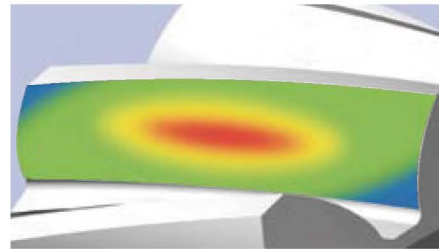

Finite element analysis of gear strength is carried out by using ANSYS technology. Tooth profile and lead trimming of tooth surface are also made to reduce the impact and noise of gear meshing, and increase the service life of gear system.



Carbon-nitriding heat-treated high quality alloy steel is adopted in gear materials to obtain the best wear resistance and impact toughness.



**PAB series**  
Take the PAB series as an example

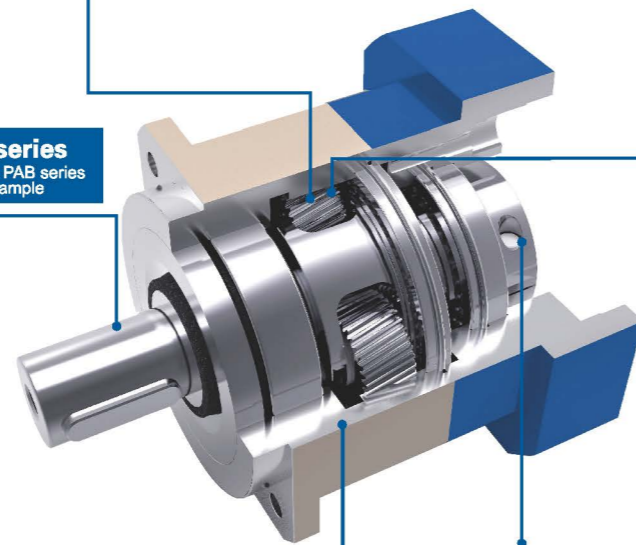

The output planet carrier adopts integral (double support) structure design. The large span of the front and rear bearings is distributed inside the box body, forming a stable integrated structure to ensure high torsion rigidity and accuracy.

An integrated design of the tooth ring and the output shell is adopted, and high quality steel is used to get high material density by hot forging. The integrated design can ensure that all geometric dimensions are finished in one time and have higher precision and strength compared with other embedded and clamped structures.

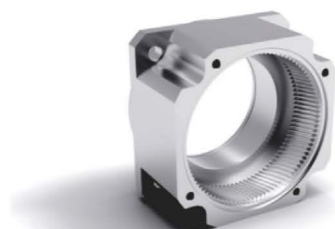

The input shaft and locking device are designed in an integrated way. The two bolts are symmetrically distributed to achieve dynamic balance. At the same time, through the strong locking of double bolts, the motor shaft transmission is effectively prevented from slipping and the high-precision zero backlash power transmission is achieved.



# PRECISION PLANETARY GEARBOX

## VRB

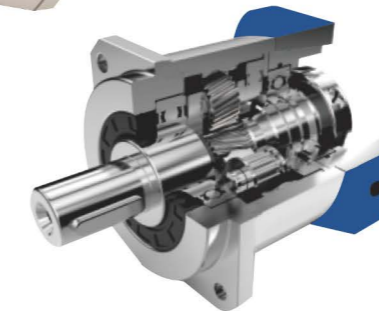

- 1. Quiet operation  
Helical gears are used to achieve smooth and quiet operation.
- 2. High precision  
The backlash is less than 3 arcmin and the positioning is accurate.
- 3. High rigidity & torque  
The use of integral ball bearings greatly improves the rigidity and torque.
- 4. Methods of flange and connector  
It can be installed on any motor in the world.
- 5. No grease leakage  
The use of grease with high viscosity which is not easy to separate effectively prevents the grease leakage.
- 6. Convenient maintenance  
No need to replace the grease in the product life period, and the installation is more convenient.

### Model Selection of Speed Reducers

VRB Type				
VRB090	-	10	-	S1 - P1 / Motor
<b>Reducer Model</b> VRB042, VRB060, VRB090, VRB115 VRB142, VRB180, VRB220		<b>Output Shaft Keyway</b> S1: (Solid Output Shaft No Keyway) S2: Standard (Keyway) S3: Output for holes		<b>Motor Model</b> Motor Manufacturer & Model
<b>Ratio</b> 1-stage: 3, 4, 5, 6, 7, 8, 9, 10 2-stage: 15, 20, 25, 30, 35, 40, 45, 50, 60, 70, 80, 90, 100			<b>Backlash Grade</b> P0: High precision backlash P1: Precision backlash P2: Standard backlash	

The gearbox matching motor needs to be confirmed with following dimensions :

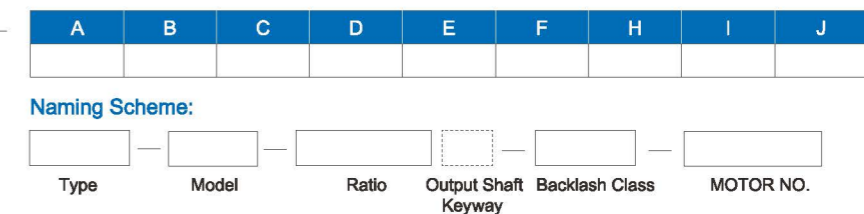
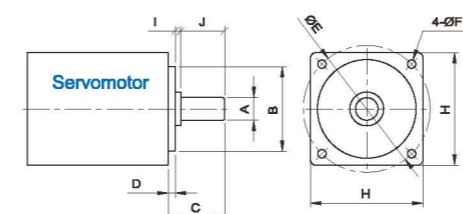

# VRB Reducer Specifications

Specs	Unit	Stage	Ratio	VRB042	VRB060	VRB090	VRB115	VRB142	VRB180	VRB220
Rated Output Torque / T2N	Nm	1	3	20	45	130	230	450	900	1500
			4	19	50	140	290	542	1050	1700
			5	22	60	160	330	650	1200	2000
			6	20	55	150	310	600	1100	1900
			7	19	50	140	300	550	1100	1800
			8	17	45	120	260	500	1000	1600
			9	14	40	100	230	450	900	1500
			10	14	40	100	208	342	588	1140
		2	15	20	45	130	230	450	900	1550
			20	19	50	140	290	542	1050	1700
			25	22	60	160	330	650	1200	2000
			30	20	55	150	310	600	1100	1900
			35	19	60	160	330	550	1100	1800
			40	17	45	120	260	500	1000	1600
			45	14	40	100	230	450	900	1500
			50	22	60	160	330	650	1200	2000
			60	20	55	150	310	600	1100	1900
			70	19	50	140	300	550	1100	1800
80	17	45	120	260	500	1000	1600			
90	14	40	100	230	450	900	1500			
100	14	40	100	208	342	588	1140			
Max.Output Torque / T2NOT <sup>1</sup>	Nm	1,2	3~100	3Times of Nominal Output Torque						
Rated Input Speed / ΠIN	rpm	1,2	3~100	5000	5000	4000	4000	3000	3000	2000
Max.Input Speed / ΠIS	rpm	1,2	3~100	10000	10000	8000	8000	6000	6000	4000
Micro Backlash P0	arcmin	1	3~10	≤1	≤1	≤1	≤1	≤1	≤1	≤1
		2	12~100	≤3	≤3	≤3	≤3	≤3	≤3	≤3
Precision Backlash P1	arcmin	1	3~10	≤3	≤3	≤3	≤3	≤3	≤3	≤3
		2	12~100	≤5	≤5	≤5	≤5	≤5	≤5	≤5
Precision Backlash P2	arcmin	1	3~10	≤5	≤5	≤5	≤5	≤5	≤5	≤5
		2	12~100	≤7	≤7	≤7	≤7	≤7	≤7	≤7
Torsional Rigidity	Nm/arcmin	1,2	3~100	3	7	14	25	50	145	225
Max.Radial Force / F2R <sup>2</sup>	N	1,2	3~100	780	1530	3250	6700	9400	14500	50000
Max.Axial Force / F2A <sup>2</sup>	N	1,2	3~100	390	765	1625	3350	4700	7250	25000
Service Life	hr	1,2	3~100	20000h						
		1	3~10	≥97%						
		2	15~100	≥94%						
Efficiency / η	%									
Weight	kg	1	3~10	0.5	1.3	3.3	7.8	15	28	52
		2	15~100	0.8	1.48	3.9	9.6	18.9	33	66
Operating Temperature	℃	1,2	3~100	(-15℃ ~ +90℃)						
Lubrication		1,2	3~100	(Synthetic Grease)						
Protection Class		1,2	3~100	IP65						
Mounting Position		1,2	3~100	(Any Direction)						
Noise Level (n1=3000rpm, No load)	dB(A)	1,2	3~100	≤56	≤58	≤60	≤63	≤65	≤67	≤70

## Reducer Rotary Inertia

Specs	Unit	Stage	Ratio	VRB042	VRB060	VRB090	VRB115	VRB142	VRB180	VRB220	
Rotary Inertia	kg.cm <sup>2</sup>	1	3	0.03	0.16	0.61	3.25	9.21	28.98	69.61	
			4	0.03	0.14	0.48	2.74	7.54	23.67	54.37	
			5	0.03	0.13	0.47	2.71	7.42	23.29	53.27	
			6	0.03	0.13	0.45	2.65	7.25	22.75	51.72	
			7	0.03	0.13	0.45	2.62	7.14	22.48	50.97	
			8	0.03	0.13	0.44	2.58	7.07	22.59	50.84	
			9	0.03	0.13	0.44	2.57	7.04	22.53	50.63	
			10	0.03	0.13	0.44	2.57	7.03	22.51	50.56	
			2	12~40	0.03	0.03	0.13	0.47	2.71	7.42	23.29
				50~100	0.03	0.03	0.13	0.44	2.57	7.03	22.51

1. Ratio (i=Nin/Nout) 2. When output speed is 100rpm, acting on the output shaft center position  
3. The Max. acceleration torque T2B=60% of T2NOT, continuous operation, service life is 10000hrs

# MODEL: VRB

1-Stage

Ratio: 3, 4, 5, 6, 7, 8, 9, 10



## Dimensions:

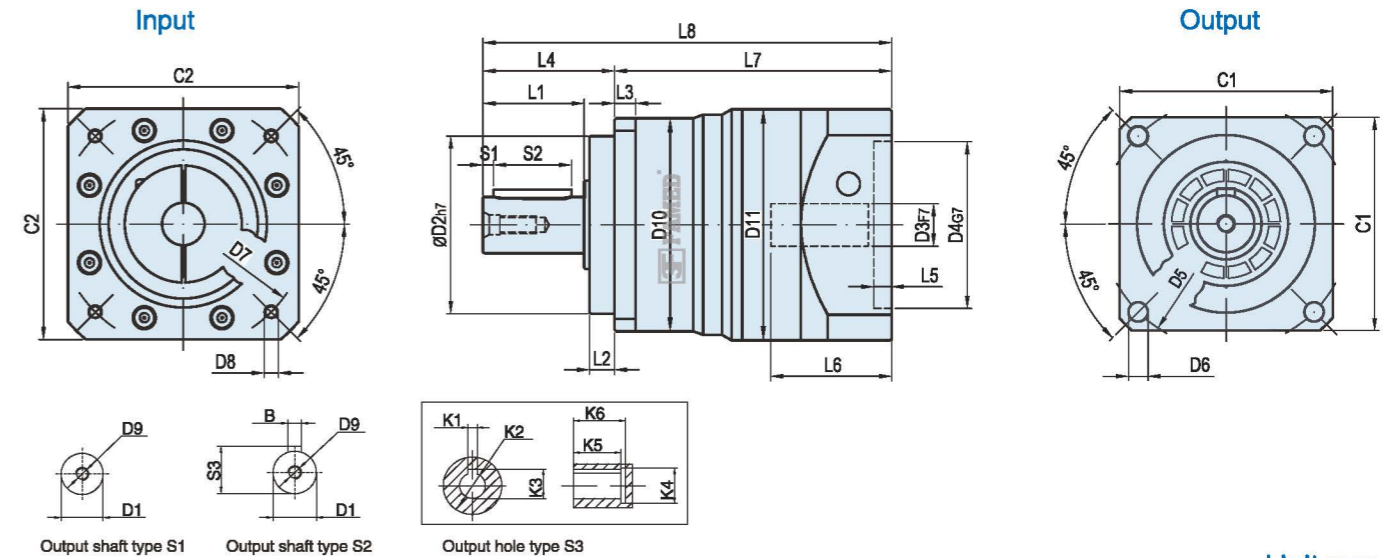

Unit:mm

Size	VRB042-L1	VRB060-L1	VRB090-L1	VRB115-L1	VRB142-L1	VRB180-L1	VRB220-L1
D1	φ 13	φ 16	φ 22	φ 32	φ 40	φ 55	φ 75
D2	φ 35	φ 50	φ 80	φ 110	φ 130	φ 160	φ 180
D3	φ 8 ( φ 6.35-11 )	φ 14 ( φ 11-19 )	φ 19 ( φ 16-24 )	φ 22 ( φ 19-35 )	φ 24 ( φ 22-35 )	φ 35 ( φ 35-42 )	φ 42 ( φ 35-55 )
D4	φ 30 ( φ 30-50 )	φ 50 ( φ 50-φ 70 )	φ 70 ( φ 70-φ 110 )	φ 110 ( φ 114.3 )	φ 110 ( φ 114.3 )	φ 114.3 ( φ 114.3-200 )	φ 180 ( φ 114.3-200 )
D5	φ 50	φ 70	φ 100	φ 130	φ 165	φ 215	φ 250
D6	4-φ 3.4	4-φ 5.5	4-φ 7	4-φ 9	4-φ 11	4-φ 13	4-φ 17
D7	φ 46 ( φ 45-70 )	φ 70 ( φ 70-φ 90 )	φ 90 ( φ 90-145 )	φ 145 ( φ 145-200 )	φ 145 ( φ 145-200 )	φ 200 ( φ 200-235 )	φ 215 ( φ 200-235 )
D8	4-M4(M3-M5)	4-M5 ( M4-M6 )	4-M6 ( M5-M8 )	4-M8 ( M8-M12 )	4-M8 ( M8-M12 )	4-M12	4-M12
D9	M4X0.7P	M5X0.8P	M8X1.25P	M12X1.75P	M16X2P	M20X2.5P	M20X2.5P
D10	φ 42	φ 60	φ 87	φ 114.5	φ 142	φ 180	φ 218
D11	φ 46	φ 65	φ 90	φ 118	φ 150	φ 184	φ 225.5
L1	19.5	28.5	36.5	51	79	82	105
L2	5.5	7	10	12	15	20	30
L3	4	6	8	10	12	15	20
L4	26	37	48	65	97	105	138
L5	5	5	7 ( 7-8 )	6 ( 6-11 )	8 ( 8-11 )	7 ( 7-10 )	8 ( 8-15 )
L6	27.5 ( ≤32 )	34 ( ≤44 )	44 ( ≤60 )	64.5 ( ≤81.5 )	72.5 ( ≤82 )	85 ( ≤120 )	109 ( ≤119 )
L7	65.5 ( 65.5-70 )	78 ( 78-88 )	98 ( 98-114 )	135 ( 135-153 )	154.5 ( 154.5-164 )	179 ( 179-214 )	220 ( 220-230 )
L8	91.5 ( 91.5-96 )	115 ( 115-125 )	146 ( 146-162 )	201 ( 201-218 )	251.5 ( 251.5-261 )	284 ( 284-319 )	358 ( 358-368 )
C1	42	60	90	115	142	180	220
C2	46(46-60)	65(65-80)	90 ( 90-130 )	130 ( 130-180 )	130 ( 130-180 )	180 ( 180-220 )	200 ( 200-220 )
S1	3	3	4	5	5	6	7
S2	14	22	28	40	65	70	90
S3	15	18	24.5	35	43	59	79.5
B	5	5	6	10	12	16	20
K1	-	4	6	8	10	14	18
K2	-	φ 11	φ 22	φ 28	φ 38	φ 50	φ 60
K3	-	12.8	24.5	31.3	41.3	53.8	64.4
K4	-	φ 16	φ 32	φ 38	φ 48	φ 60	φ 72
K5	-	15	20	27	35	43	60
K6	-	18	24	32	40	50	65

Note 1: Inside of ( ) is the optional range of sizes, outside of ( ) is the standard sizes.  
Note 2: The reducer output shaft size and length can be customized for customers.  
Note 3: The input size can be changed according to the servomotor or stepper motor of each brand.

# MODEL: VRB

2-Stage

Ratio: 15, 20, 25, 30, 35, 40, 45, 50, 60  
70, 80, 90, 100



## Dimensions:

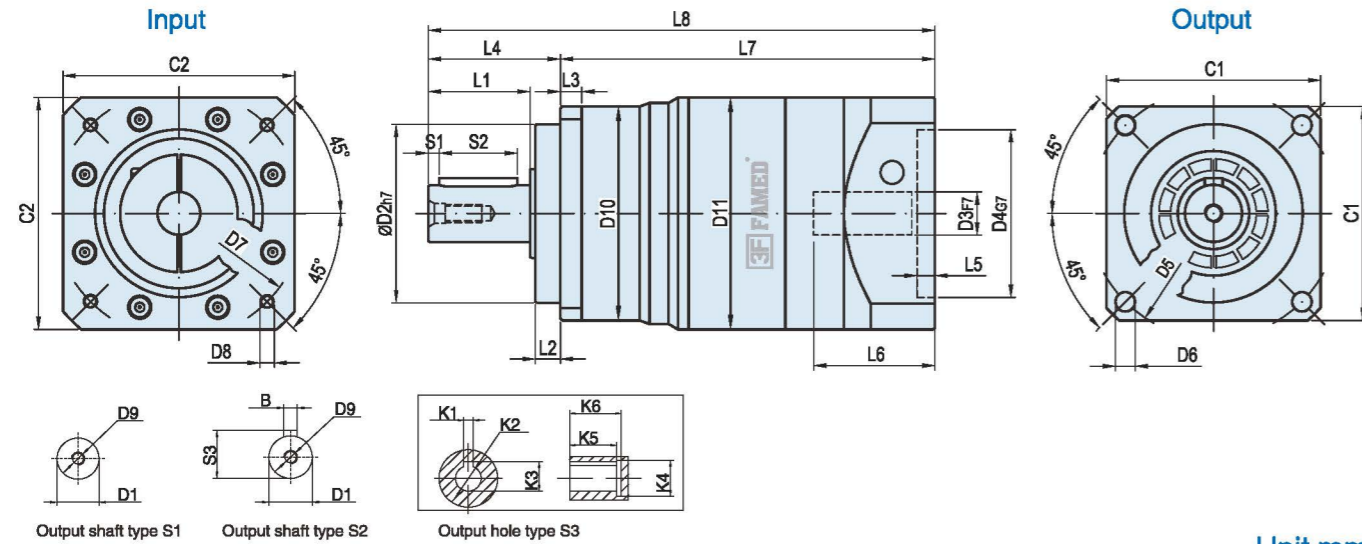

Unit:mm

Size	VRB042-L2	VRB060-L2	VRB090-L2	VRB115-L2	VRB142-L2	VRB180-L2	VRB220-L2
D1	φ 13	φ 16	φ 22	φ 32	φ 40	φ 55	φ 75
D2	φ 35	φ 50	φ 80	φ 110	φ 130	φ 160	φ 180
D3	φ 8 ( φ 6.35-8 )	φ 14 ( φ 11-14 )	φ 19 ( φ 11-19 )	φ 22 ( φ 16-24 )	φ 24 ( φ 19-35 )	φ 35 ( φ 22-35 )	φ 42 ( φ 35-42 )
D4	φ 30 ( φ 30-38.1 )	φ 50	φ 70 ( φ 50-φ 80 )	φ 110 ( φ 70-110 )	φ 110 ( φ 70-114.3 )	φ 114.3 ( φ 110-114.3 )	φ 180 ( φ 114.3-200 )
D5	φ 50	φ 70	φ 100	φ 130	φ 165	φ 215	φ 250
D6	4-φ 3.4	4-φ 5.5	4-φ 7	4-φ 9	4-φ 11	4-φ 13	4-φ 17
D7	φ 46 ( φ 45-66.67 )	φ 70	φ 90 ( φ 70-100 )	φ 145 ( φ 90-145 )	φ 145 ( φ 145-200 )	φ 200 ( φ 145-200 )	φ 215 ( φ 200-235 )
D8	4-M4(M3)	4-M5 (M4)	4-M6 (M4-M6)	4-M8 (M5-M8)	4-M8 (M8-M12)	4-M12 (M8-M12)	4-M12
D9	M4X0.7P	M5X0.8P	M8X1.25P	M12X1.75P	M16X2P	M20X2.5P	M20X2.5P
D10	φ 42	φ 60	φ 87	φ 114.5	φ 142	φ 180	φ 218
D11	φ 46	φ 65	φ 90	φ 118	φ 150	φ 184	φ 225.5
L1	19.5	28.5	36.5	51	79	82	105
L2	5.5	7	10	12	15	20	30
L3	4	6	8	10	12	15	20
L4	26	37	48	65	97	105	138
L5	5	5	5	8 (7-8)	11 (6-11)	8 (8-11)	8 (7-10)
L6	27.5	34	34 ( ≤44 )	44 ( ≤60 )	64.5 ( ≤81.5 )	72.5 ( ≤82 )	85 ( ≤120 )
L7	86	105	124.5 ( 114.5-124.5 )	165.5 ( 149.5-165.5 )	206 ( 189-206 )	235 ( 225.5-235 )	269 ( 264-299 )
L8	112	142	172.5 ( 162.5-172.5 )	230.5 ( 214.5-230.5 )	303 ( 286-303 )	340 ( 330.5-340 )	407 ( 402-437 )
C1	42	60	90	115	142	180	220
C2	46 ( 46-57 )	65	65 ( 65-86 )	90 ( 90-130 )	130 ( 130-180 )	150 ( 150-180 )	200 ( 180-220 )
S1	3	3	4	5	5	6	7
S2	14	22	28	40	65	70	90
S3	15	18	24.5	35	43	59	79.5
B	5	5	6	10	12	16	20
K1	-	4	6	8	10	14	18
K2	-	φ 11	φ 22	φ 28	φ 38	φ 50	φ 60
K3	-	12.8	24.5	31.3	41.3	53.8	64.4
K4	-	φ 16	φ 32	φ 38	φ 48	φ 60	φ 72
K5	-	15	20	27	35	43	60
K6	-	18	24	32	40	50	65

Note 1: Inside of ( ) is the optional range of sizes, outside of ( ) is the standard sizes.  
 Note 2: The reducer output shaft size and length can be customized for customers.  
 Note 3: The input size can be changed according to the servomotor or stepper motor of each brand.

# PRECISION PLANETARY GEARBOX

## EVB



- 1. Quiet operation  
Helical gears are used to achieve smooth and quiet operation.
- 2. High precision  
The backlash is less than 3 arcmin and the positioning is accurate.
- 3. High rigidity & torque  
The use of integral ball bearings greatly improves the rigidity and torque.
- 4. Methods of flange and connector  
It can be installed on any motor in the world.
- 5. No grease leakage  
The use of grease with high viscosity which is not easy to separate effectively prevents the grease leakage.
- 6. Convenient maintenance  
No need to replace the grease in the product life period, and the installation is more convenient.

## Model Selection of Speed Reducers

**EVB Type**

EVB090 - 10 - S1 - P1 / Motor

**Reducer Model**

EVB042, EVB060, EVB090, EVB115  
EVB142, EVB180, EVB220

**Output Shaft Keyway**

S1: (Solid Output Shaft No Keyway)  
S2: Standard (Keyway)  
S3: Output for holes

**Motor Model**

Motor Manufacturer & Model

**Ratio**

1-stage: 3, 4, 5, 6, 7, 8, 9, 10, 14, 16, 20  
2-stage: 15, 20, 25, 30, 35, 40, 50, 70, 80, 100, 120, 140, 160, 180, 200

**Backlash Grade**

P0: High precision backlash  
P1: Precision backlash  
P2: Standard backlash

The gearbox matching motor needs to be confirmed with following dimensions :

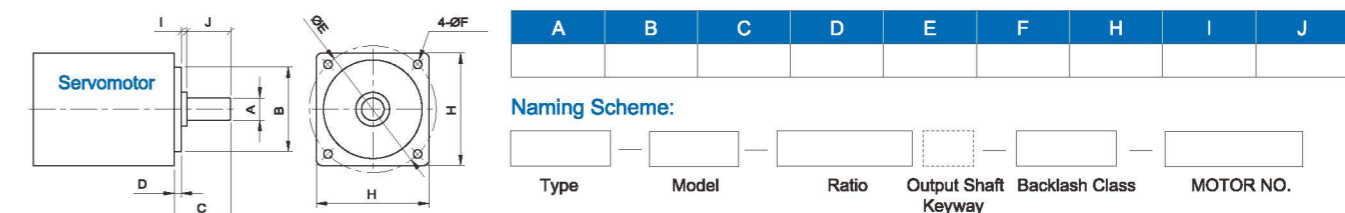

## Reducer Specifications

Specs	Unit	Stage	Ratio	EVB042	EVB060	EVB090	EVB115	EVB142	EVB180	EVB220
Rated Output Torque / T2N	Nm	1	3	20	45	130	230	450	900	1500
			4	19	50	140	290	542	1050	1700
			5	22	60	160	330	650	1200	2000
			6	20	55	150	310	600	1100	1900
			7	19	50	140	300	550	1100	1800
			8	17	45	120	260	500	1000	1600
			9	14	40	100	230	450	900	1500
			10	14	40	100	208	342	588	1140
			14	19	50	140	230	450	900	1550
			20	14	40	100	290	542	1050	1700
		2	15	20	55	130	230	650	900	1140
			20	20	55	150	310	600	1100	1900
			25	22	60	160	330	550	1100	1800
			30	20	45	120	260	500	1000	1600
			35	19	40	100	230	450	900	1500
			40	17	60	160	330	650	1200	2000
			50	22	50	140	300	550	1100	1800
			70	19	45	120	260	500	1000	1600
			80	17	40	100	230	450	900	1500
			100	14	40	100	208	342	588	1140
120	—	—	128	305	495	1095	1895			
140	—	—	128	295	525	1095	1795			
160	—	—	118	255	515	995	1595			
180	—	—	98	225	445	895	1495			
200	—	—	98	225	445	895	1495			
Max. Output Torque / T2NOT <sup>1</sup>	Nm	1,2	3~200	3Times of Nominal Output Torque						
Rated Input Speed / Π <sub>IN</sub>	rpm	1,2	3~200	3000	3000	3000	3000	2500	2000	2000
Max. Input Speed / Π <sub>IS</sub>	rpm	1,2	3~200	6000	6000	6000	5500	4500	4500	4000
Precision Backlash P0	arcmin	1	3~20	≤2	≤2	≤2	≤2	≤2	≤2	≤2
		2	15~200	≤4	≤4	≤4	≤4	≤4	≤4	≤4
Precision Backlash P1	arcmin	1	3~20	≤4	≤4	≤4	≤4	≤4	≤4	≤4
		2	15~200	≤6	≤6	≤6	≤6	≤6	≤6	≤6
Standard Backlash P2	arcmin	1	3~20	≤6	≤6	≤6	≤6	≤6	≤6	≤6
		2	15~200	≤8	≤8	≤8	≤8	≤8	≤8	≤8
Torsional Rigidity	Nm/arcmin	1,2	3~200	3	6	14	25	56	140	220
Max. Radial Force / F <sub>2R</sub> <sup>2</sup>	N	1,2	3~200	780	1300	3200	6750	9400	14500	50000
Max. Axial Force / F <sub>2A</sub> <sup>2</sup>	N	1,2	3~200	330	700	1580	3300	4700	7200	28000
Service Life	hr	1,2	3~200	21000 h						
		1	3~20	≥93%						
Efficiency / η	%	2	25~200	≥90%						
		1	3~20	0.9	1.5	6.4	13	24.5	51	83
Weight	kg	2	25~200	1.2	2.1	7.8	14.2	27.5	54	95
		1,2	3~200	(-15°C ~ +90°C)						
Operating Temperature	°C	1,2	3~200	(Synthetic Grease)						
Lubrication		1,2	3~200	IP65						
Protection Class		1,2	3~200	(Any Direction)						
Mounting Position		1,2	3~200							
Noise Level (n1=3000rpm, No load)	dB(A)	1,2	3~200	≤65	≤65	≤68	≤68	≤70	≤72	≤74

## Reducer Rotary Inertia

Specs	Unit	Stage	Ratio	EVB042	EVB060	EVB090	EVB115	EVB142	EVB180	EVB220
Moment of Inertia	kg.cm <sup>2</sup>	1	3~10	0.09	0.35	2.25	6.84	23.4	68.9	135.4
			14~20	0.03	0.07	1.87	6.25	21.8	65.6	119.8
		2	15~100	0.09	0.09	0.35	2.25	6.84	23.4	68.9
120~200	—		—	0.31	1.87	6.25	21.8	65.6		

1. The Max. acceleration torque T2B=60% of T2NOT 2. When output speed is 100rpm, inertia acts on the output shaft center position.  
3. 3-stage big ratios are not in the above table. There is shaft lengthening and enlarging design. Please tell sales person if you need it.

# MODEL: EVB

1-Stage

Ratio: 3, 4, 5, 6, 7, 8, 9, 10, 14, 16, 20



## Dimensions:

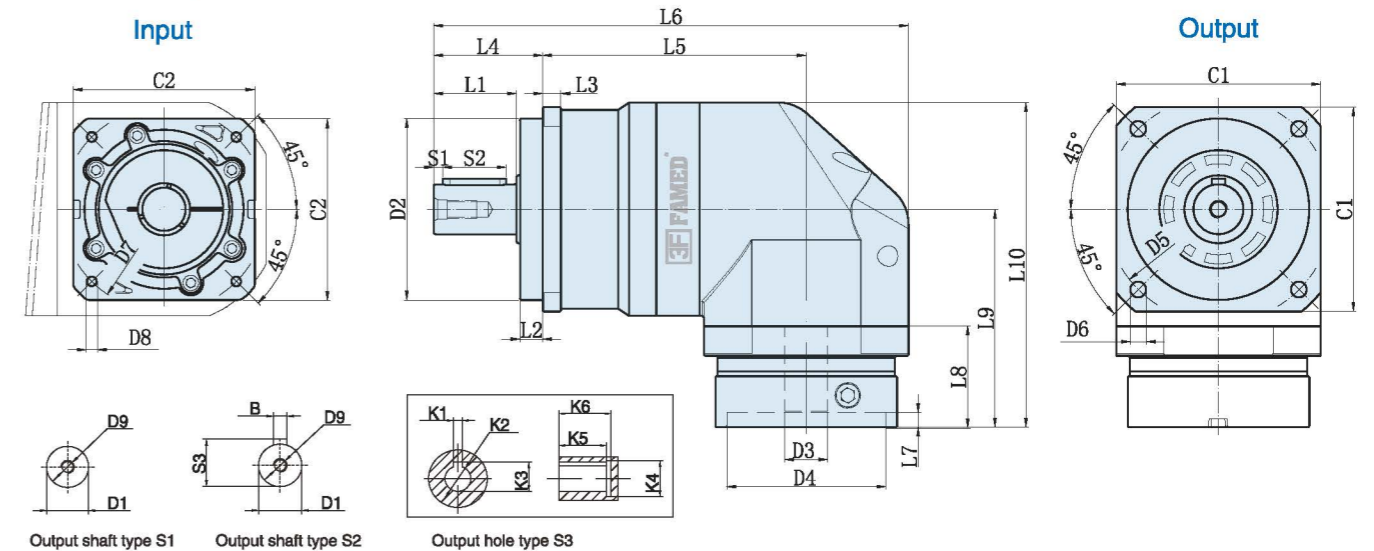

Unit:mm

Size	EVB042-L1	EVB060-L1	EVB090-L1	EVB115-L1	EVB142-L1	EVB180-L1	EVB220-L1
D1	φ 13	φ 16	φ 22	φ 32	φ 40	φ 55	φ 75
D2	φ 35	φ 50	φ 80	φ 110	φ 130	φ 160	φ 180
D3	φ 8(≤11)	φ 14(≤14)	φ 19(≤24)	φ 24(≤32)	φ 35(≤42)	φ 38(≤50)	φ 55(≤55)
D4	φ 30(30~50)	φ 50 (50~70)	φ 70 (50~110)	φ 110 (50~130)	φ 114.3(95~180)	φ 180(95~180)	φ 215(180~255)
D5	φ 50	φ 70	φ 100	φ 130	φ 165	φ 215	φ 250
D6	4-φ 3.4	4-φ 5.5	4-φ 7	4-φ 9	4-φ 11	4-φ 13	4-φ 17
D7	φ 46(22~70)	φ 70 (70~130)	φ 90 (70~145)	φ 145 (70~145)	φ 200(90~215)	φ 200(90~300)	φ 235(200~300)
D8	(4-M3X8L)	(4-M4*8L)	(4-M6*10L)	(4-M8*20L)	(4-M12X30L)	(4-M12X30L)	(4-M12X30L)
D9	M4X0.7P	M5*0.8P*18L	M6*1.25P*19L	M12*1.75P*28L	M16X2.0P	M20X2.5P	M20X2.5P
L1	19	28.5	36.5	51	79	82	105
L2	5.5	7	10	12	15	20	30
L3	4	6	8	10	12	15	20
L4	26	37	48	65	97	105	138
L5	96	86	116	137.5	255	289	346
L6	(122)	153	209	260	(352)	(394)	(484)
L7	(3.5)	(5)	(6.5)	(10)	(14)	(15)	(7)
L8	(30)	(33)	(45)	(64)	(81)	(85)	(85)
L9	(69.5)	(77.5)	(96)	(135.5)	(165)	(213.5)	(268.5)
L10	(95.5)	(111.75)	(143)	(195)	(230)	(303.5)	(378.5)
C1	□42	□60	□90	□115	□142	□180	□220
C2	(□42)	(□60)	(□80)	(□130)	(□142)	(□180)	(□220)
S1	2	3	4	5	5	5	7
S2	16	22	28	40	65	70	90
S3	15	18	24.5	35	43	59	79
B	5	5	6	10	12	16	20
K1	—	3	6	8	10	14	16
K2	—	φ 8	φ 18	φ 28	φ 38	φ 50	φ 60
K3	—	9.2	21	31.3	42	53.8	64.4
K4	—	φ 11	φ 24	φ 38	φ 48	φ 60	φ 72
K5	—	16	30	27	35	43	60
K6	—	18	35	32	40	50	65

Note 1: Inside of ( ) is the optional range of sizes, outside of ( ) is the standard sizes.

Note 2: The reducer output shaft size and length can be customized for customers.

Note 3: The input size can be changed according to the servomotor or stepper motor of each brand.

# MODEL: EVB

2-Stage

Ratio: 15, 20, 25, 30, 35, 40, 50, 70, 80  
100, 120, 140, 160, 180, 200



## Dimensions:

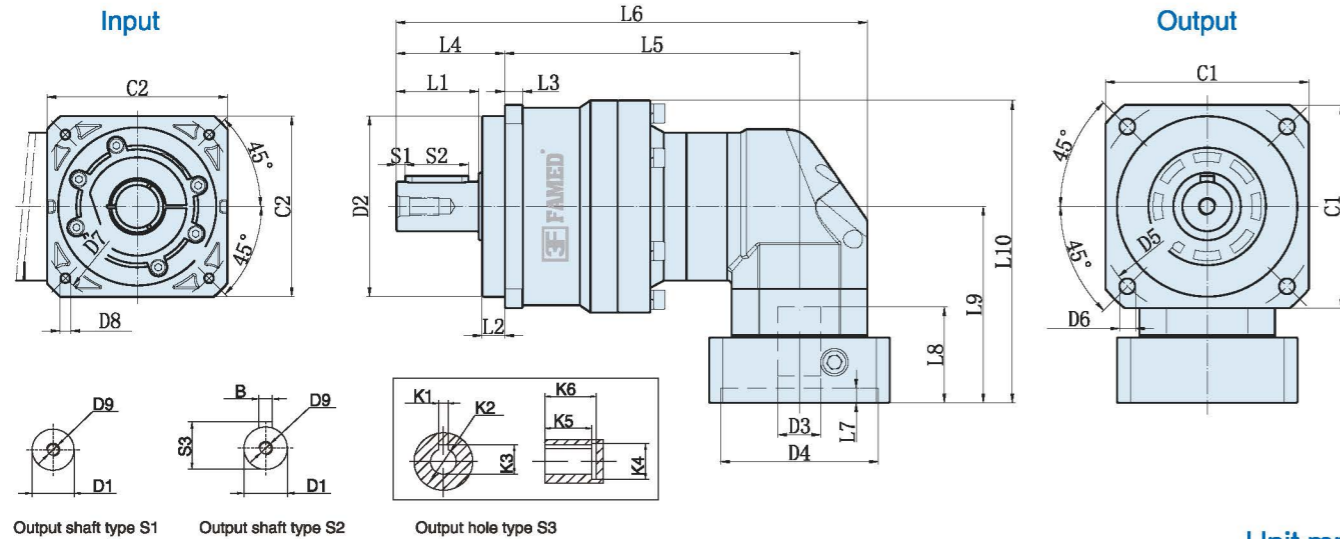

Unit:mm

Size	EVB042-L2	EVB060-L2	EVB090-L2	EVB115-L2	EVB142-L2	EVB180-L2	EVB220-L2
D1	φ 13	φ 16	φ 22	φ 32	φ 40	φ 55	φ 75
D2	φ 35	φ 50	φ 80	φ 110	φ 130	φ 160	φ 180
D3	φ 8(≤11)	φ 14(≤14)	φ 19(≤24)	φ 24(≤32)	φ 35(≤42)	φ 38(≤50)	φ 55(≤55)
D4	φ 30(30-50)	φ 50 ( 50-70 )	φ 70 ( 50-110 )	φ 110 ( 50-130 )	φ 114.3(95-180)	φ 180(95-180)	φ 215(180-255)
D5	φ 50	φ 70	φ 100	φ 130	φ 165	φ 215	φ 250
D6	4-φ 3.4	4-φ 5.5	4-φ 7	4-φ 9	4-φ 11	4-φ 13	4-φ 17
D7	φ 46(22-70)	φ 70 ( 70-130 )	φ 90 ( 70-145 )	φ 145 ( 70-145 )	φ 200(90-215)	φ 200(90-300)	φ 235(200-300)
D8	(4-M3X8L)	( 4-M4*8L )	( 4-M6*10L )	( 4-M8*20L )	(4-M12X30L)	(4-M12X30L)	(4-M12X30L)
D9	M4X0.7P	M5*0.8P*18L	M6*1.25P*19L	M12*1.75P*28L	M16X2.0P	M20X2.5P	M20X2.5P
L1	19	28.5	36.5	51	79	82	105
L2	5.5	7	10	12	15	20	30
L3	4	6	8	10	12	15	20
L4	26	37	48	65	97	105	138
L5	113	115	130.5	167.5	282	322	383
L6	139	182	208.5	277.5	(378)	(427)	(521)
L7	( 3.5 )	( 5 )	( 6.5 )	( 10 )	( 14 )	( 15 )	( 7 )
L8	(30)	(33)	(42.5)	(59)	( 81 )	( 85 )	( 85 )
L9	(69.5)	(77.5)	(87)	(120)	(165)	(213.5)	(268.5)
L10	( 90.5 )	(111.75)	(134)	(179.5)	( 236 )	( 303.5 )	( 378.5 )
C1	□42	□60	□90	□115	□142	□180	□220
C2	(□42)	( □60 )	( □80 )	( □130 )	(□142)	(□180)	(□220)
S1	2	3	4	5	5	5	7
S2	16	22	28	40	65	70	90
S3	15	18	24.5	35	43	59	79
B	5	5	6	10	12	16	20
K1	-	3	6	8	10	14	16
K2	-	φ 8	φ 18	φ 28	φ 38	φ 50	φ 60
K3	-	9.2	21	31.3	42	53.8	64.4
K4	-	φ 11	φ 24	φ 38	φ 48	φ 60	φ 72
K5	-	20	30	27	35	43	60
K6	-	24	35	32	40	50	65

Note 1: Inside of ( ) is the optional range of sizes, outside of ( ) is the standard sizes.  
Note 2: The reducer output shaft size and length can be customized for customers.  
Note 3: The input size can be changed according to the servomotor or stepper motor of each brand.

# PRECISION PLANETARY GEARBOX

## VRL

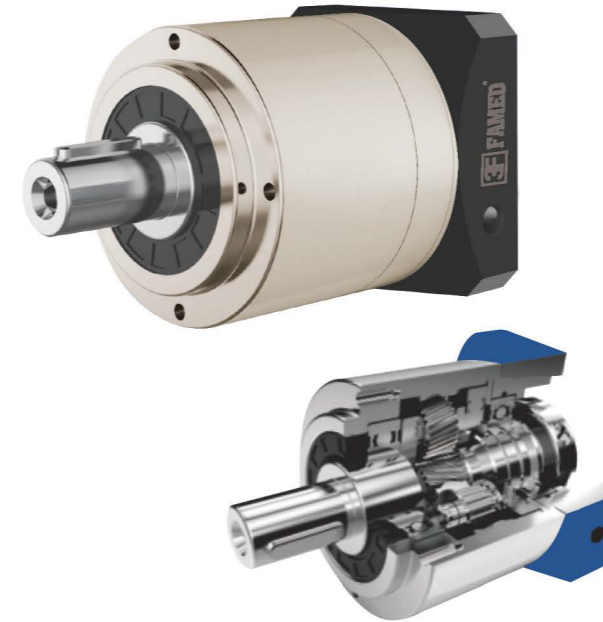

- 1. Quiet operation  
Helical gears are used to achieve smooth and quiet operation.
- 2. High precision  
The backlash is less than 3 arcmin and the positioning is accurate.
- 3. High rigidity & torque  
The use of integral ball bearings greatly improves the rigidity and torque.
- 4. Methods of flange and connector  
It can be installed on any motor in the world.
- 5. No grease leakage  
The use of grease with high viscosity which is not easy to separate effectively prevents the grease leakage.
- 6. Convenient maintenance  
No need to replace the grease in the product life period, and the installation is more convenient.

## Model Selection of Speed Reducers

### VRL Type

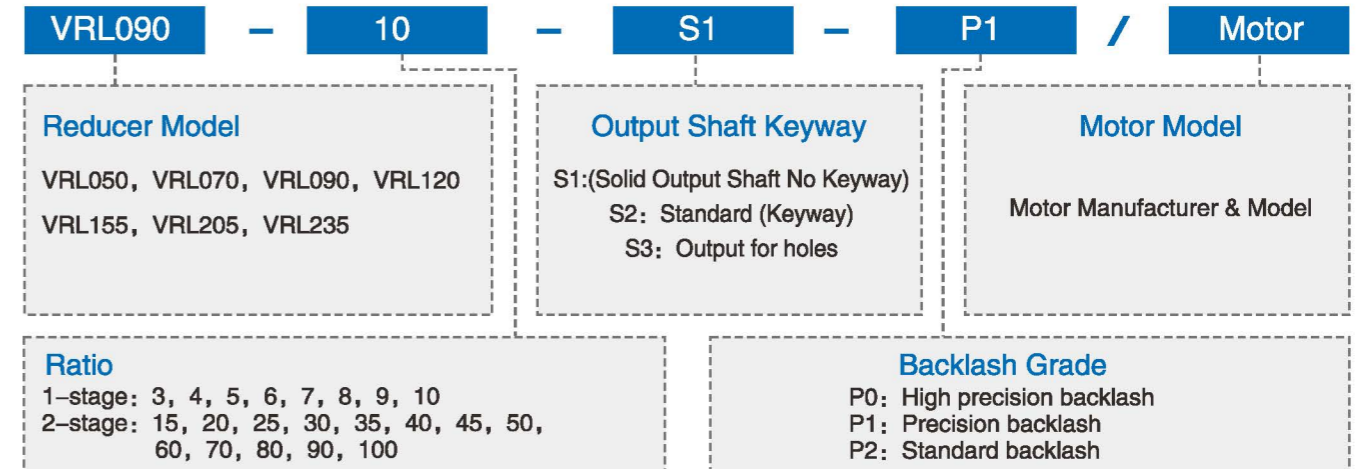

The gearbox matching motor needs to be confirmed with following dimensions :

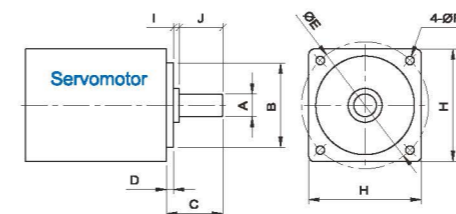

A	B	C	D	E	F	H	I	J

Naming Scheme:

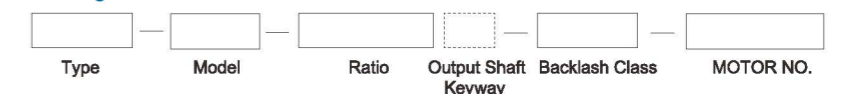

# VRL Reducer Specifications

Specs	Unit	Stage	Ratio	VRL050	VRL070	VRL090	VRL120	VRL155	VRL205	VRL235
Rated Output Torque / T2N	Nm	1	3	20	45	130	230	450	900	1500
			4	19	50	140	290	542	1050	1700
			5	22	60	160	330	650	1200	2000
			6	20	55	150	310	600	1100	1900
			7	19	50	140	300	550	1100	1800
			8	17	45	120	260	500	1000	1600
			9	14	40	100	230	450	900	1500
		10	14	40	100	208	342	588	1140	
		2	15	20	45	130	230	450	900	1550
			20	19	50	140	290	542	1050	1700
			25	22	60	160	330	650	1200	2000
			30	20	55	150	310	600	1100	1900
			35	19	60	160	330	550	1100	1800
			40	17	45	120	260	500	1000	1600
			45	14	40	100	230	450	900	1500
			50	22	60	160	330	650	1200	2000
			60	20	55	150	310	600	1100	1900
			70	19	50	140	300	550	1100	1800
80	17		45	120	260	500	1000	1600		
90	14	40	100	230	450	900	1500			
100	14	40	100	208	342	588	1140			
Max.Output Torque / T <sub>2NOT</sub> <sup>1</sup>	Nm	1,2	3~100	3Times of Nominal Output Torque						
Rated Input Speed / Π <sub>1N</sub>	rpm	1,2	3~100	5000	5000	4000	4000	3000	3000	2000
Max.Input Speed / Π <sub>1B</sub>	rpm	1,2	3~100	10000	10000	8000	8000	6000	6000	4000
Micro Backlash P0	arcmin	1	3~10	≤1	≤1	≤1	≤1	≤1	≤1	≤1
		2	15~100	≤3	≤3	≤3	≤3	≤3	≤3	≤3
Precision Backlash P1	arcmin	1	3~10	≤3	≤3	≤3	≤3	≤3	≤3	≤3
		2	15~100	≤5	≤5	≤5	≤5	≤5	≤5	≤5
Precision Backlash P2	arcmin	1	3~10	≤5	≤5	≤5	≤5	≤5	≤5	≤5
		2	15~100	≤7	≤7	≤7	≤7	≤7	≤7	≤7
Torsional Rigidity	Nm/arcmin	1,2	3~100	3	7	14	25	50	145	225
Max.Radial Force / F <sub>2B</sub> <sup>2</sup>	N	1,2	3~100	680	1260	2880	6000	8200	12800	27800
Max.Axial Force / F <sub>2A1B</sub> <sup>2</sup>	N	1,2	3~100	370	760	1580	3360	4660	7250	18500
Service Life	hr	1,2	3~100	20000h						
Efficiency / η	%	1	3~10	≥97%						
		2	15~100	≥94%						
Weight	kg	1	3~10	0.5	1.2	3.5	7.8	14.5	30	50
		2	15~100	0.8	1.4	4.1	9	17.5	33	63
Operating Temperature	℃	1,2	3~100	(-15℃ ~ +90℃)						
Lubrication		1,2	3~100	(Synthetic Grease)						
Protection Class		1,2	3~100	IP65						
Mounting Position		1,2	3~100	(Any Direction)						
Noise Level (n1=3000rpm, No load)	dB(A)	1,2	3~100	≤56	≤58	≤60	≤63	≤65	≤67	≤70

## Reducer Rotary Inertia

Specs	Unit	Stage	Ratio	VRL050	VRL070	VRL090	VRL120	VRL155	VRL205	VRL235
Moment of Inertia	kg.cm <sup>2</sup>	1	3	0.03	0.16	0.61	3.25	9.21	28.98	69.61
			4	0.03	0.14	0.48	2.74	7.54	23.67	54.37
			5	0.03	0.13	0.47	2.71	7.42	23.29	53.27
			6	0.03	0.13	0.45	2.65	7.25	22.75	51.72
			7	0.03	0.13	0.45	2.62	7.14	22.48	50.97
			8	0.03	0.13	0.44	2.58	7.07	22.59	50.84
			9	0.03	0.13	0.44	2.57	7.04	22.53	50.63
		10	0.03	0.13	0.44	2.57	7.03	22.51	50.56	
		2	12~40	0.03	0.03	0.13	0.47	2.71	7.42	23.29
			50~100	0.03	0.03	0.13	0.44	2.57	7.03	22.51

1. Ratio (i=Nin/Nout) 2. Output revolutions 100rpm, acting on the output shaft center position.  
3. The Max. acceleration torque T2B=60% of T2NOT, continuous operation, service life is 10000hrs.

# MODEL: VRL

1-Stage

Ratio: 3, 4, 5, 6, 7, 8, 9, 10



## Dimensions:

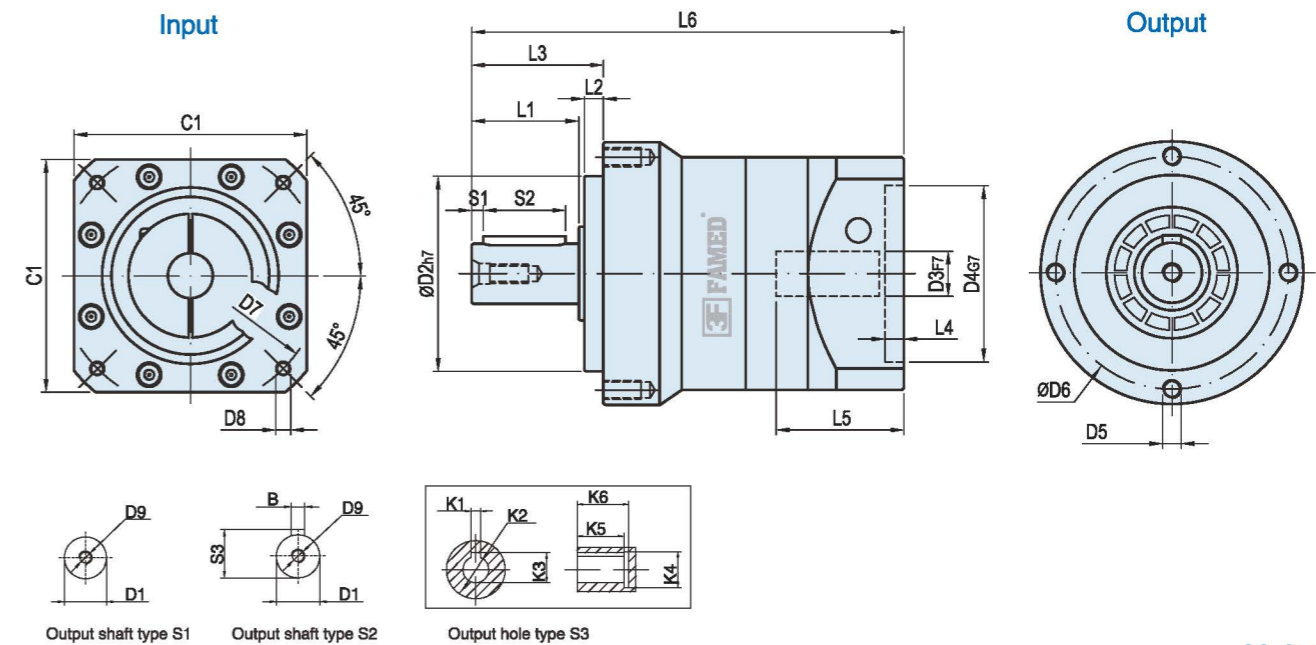

Unit:mm

Size	VRL070-L1	VRL090-L1	VRL120-L1	VRL155-L1	VRL205-L1	VRL235-L1
D1	φ 16	φ 22	φ 32	φ 40	φ 55	φ 75
D2	φ 52	φ 68	φ 90	φ 120	φ 160	φ 180
D3	φ 14 ( φ 11-14 )	φ 19 ( φ 16-24 )	φ 22 ( φ 19-35 )	φ 24 ( φ 22-35 )	φ 35 ( φ 35-φ 42 )	φ 42 ( φ 35-55 )
D4	φ 50 ( φ 50-70 )	φ 70 ( φ 70-φ 110 )	φ 110 ( φ 114.3 )	φ 110 ( φ 114.3 )	φ 114.3 ( φ 114.3-200 )	φ 180 ( φ 114.3-200 )
D5	4-M5X10L	4-M6X12L	4-M8X16L	4-M10X20L	4-M12X22L	4-M16X28L
D6	φ 62	φ 80	φ 108	φ 140	φ 184	φ 210
D7	φ 70 ( φ 70-90 )	φ 90 ( φ 90-145 )	φ 145 ( φ 145-200 )	φ 145 ( φ 145-200 )	φ 200 ( φ 200-235 )	φ 215 ( φ 200-235 )
D8	4-M5 ( M4-M6 )	4-M6 ( M5-M8 )	4-M8 ( M8-M12 )	4-M8 ( M8-M12 )	4-M12	4-M12
D9	M5X0.8P	M8X1.25P	M12X1.75P	M16X2P	M20X2.5P	M20X2.5P
L1	28.5	36.5	51	79	82	105
L2	5	6	9	12	15	18
L3	35	44	62	94	100	126
L4	5	7-8	6-11	8-11	7-10	8-15
L5	34 ( ≤44 )	44 ( ≤60 )	64.5 ( ≤81.5 )	72.5 ( ≤82 )	85 ( ≤120 )	109 ( ≤119 )
L6	115 ( 115-125 )	146 ( 146-162 )	201 ( 201-218 )	251.5 ( 251.5-261 )	284 ( 284-319 )	358 ( 358-368 )
C1	65 ( 65-80 )	90 ( 90-130 )	130 ( 130-180 )	150 ( 150-180 )	180 ( 180-220 )	200 ( 200-220 )
S1	3	4	5	5	6	7
S2	22	28	40	65	70	90
S3	18	24.5	35	43	59	79.5
B	5	6	10	12	16	20
K1	4	6	8	10	14	18
K2	φ 11	φ 22	φ 28	φ 38	φ 50	φ 60
K3	12.8	24.5	31.3	41.3	53.8	64.4
K4	φ 16	φ 32	φ 38	φ 48	φ 60	φ 72
K5	15	20	27	35	43	60
K6	18	24	32	40	50	65

Note 1: Inside of ( ) is the optional range of sizes, outside of ( ) is the standard sizes.  
Note 2: The reducer output shaft size and length can be customized for customers.  
Note 3: The input size can be changed according to the servomotor or stepper motor of each brand.

# MODEL: VRL

2-Stage

Ratio: 15, 20, 25, 30, 35, 40, 45, 50,  
60, 70, 80, 90, 100



## Dimensions:

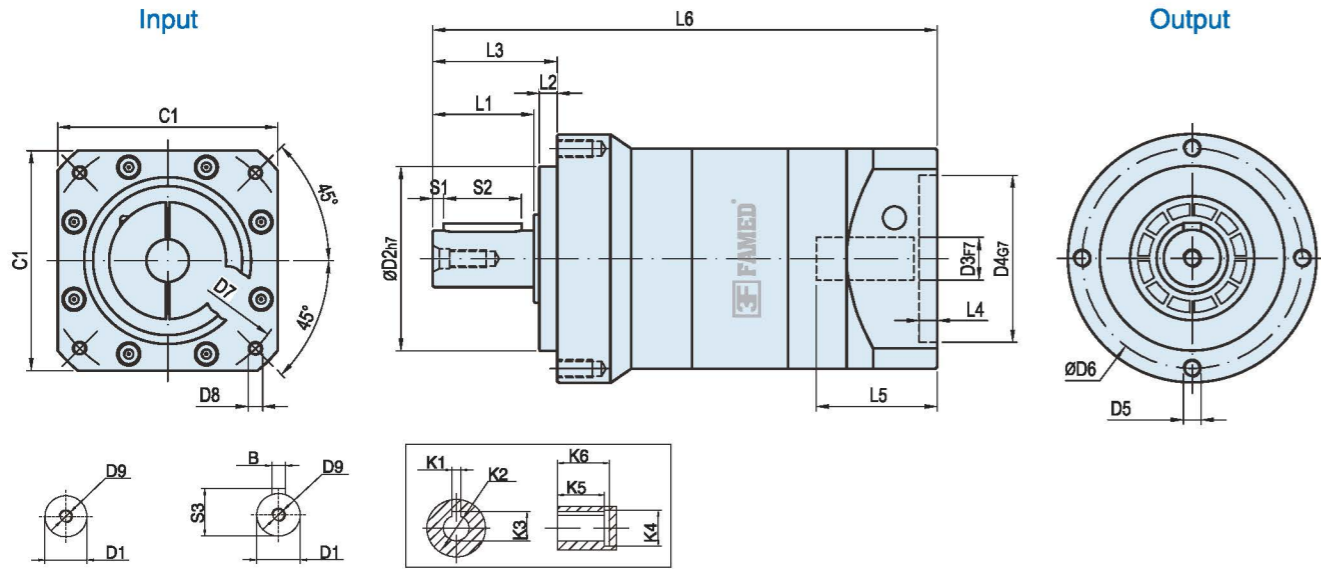

Unit:mm

Size	VRL070-L1	VRL090-L2	VRL120-L2	VRL155-L2	VRL205-L2	VRL235-L2
D1	φ 16	φ 22	φ 32	φ 40	φ 55	φ 75
D2	φ 52	φ 68	φ 90	φ 120	φ 160	φ 180
D3	φ 14 ( φ 11-14 )	φ 19 ( φ 11-19 )	φ 22 ( φ 16-24 )	φ 24 ( φ 19-35 )	φ 35 ( φ 22-35 )	φ 42 ( φ 35-42 )
D4	φ 50	φ 70 ( φ 50-φ 80 )	φ 110 ( φ 70-φ 110 )	φ 110 ( φ 114.3 )	φ 110 ( φ 114.3 )	φ 180 ( φ 114.3-200 )
D5	4-M5X10L	4-M6X12L	4-M8X16L	4-M10X20L	4-M12X22L	4-M16X28L
D6	φ 62	φ 80	φ 108	φ 140	φ 184	φ 210
D7	φ 70	φ 90 ( φ 70-100 )	φ 145 ( φ 90-145 )	φ 145 ( φ 145-200 )	φ 145 ( φ 145-200 )	φ 215 ( φ 200-235 )
D8	4-M5 ( M4 )	4-M6 ( M4-M6 )	4-M8 ( M5-M8 )	4-M8 ( M8-M12 )	4-M8 ( M8-M12 )	4-M12
D9	M5X0.8P	M8X1.25P	M12X1.75P	M16X2P	M20X2.5P	M20X2.5P
L1	28.5	36.5	51	79	82	105
L2	5	6	9	12	15	18
L3	35	44	62	94	100	126
L4	5	5	8 ( 7-8 )	11 ( 6-11 )	8 ( 8-11 )	8 ( 7-10 )
L5	34	34 ( ≤44 )	44 ( ≤60 )	64.5 ( ≤81.5 )	72.5 ( ≤82 )	85 ( ≤120 )
L6	142	172.5 ( 162.5-172.5 )	230.5 ( 214.5-230.5 )	286 ( 286-303 )	340 ( 330.5-340 )	407 ( 402-437 )
C1	65	80 ( 65-86 )	130 ( 90-130 )	130 ( 130-180 )	150 ( 150-180 )	200 ( 180-220 )
S1	3	4	5	5	6	7
S2	22	28	40	65	70	90
S3	18	24.5	35	43	59	79.5
B	5	6	10	12	16	20
K1	4	6	8	10	14	18
K2	φ 11	φ 22	φ 28	φ 38	φ 50	φ 60
K3	12.8	24.5	31.3	41.3	53.8	64.4
K4	φ 16	φ 32	φ 38	φ 48	φ 60	φ 72
K5	15	20	27	35	43	60
K6	18	24	32	40	50	65

Note 1: Inside of ( ) is the optional range of sizes, outside of ( ) is the standard sizes.

Note 2: The reducer output shaft size and length can be customized for customers.

Note 3: The input size can be changed according to the servomotor or stepper motor of each brand.

# PRECISION PLANETARY GEARBOX

## EVL



- 1. Quiet operation  
Helical gears are used to achieve smooth and quiet operation.
- 2. High precision  
The backlash is less than 3 arcmin and the positioning is accurate.
- 3. High rigidity & torque  
The use of integral ball bearings greatly improves the rigidity and torque.
- 4. Methods of flange and connector  
It can be installed on any motor in the world.
- 5. No grease leakage  
The use of grease with high viscosity which is not easy to separate effectively prevents the grease leakage.
- 6. Convenient maintenance  
No need to replace the grease in the product life period, and the installation is more convenient.

## Model Selection of Speed Reducers

**EVL Type**

**EVL090 - 10 - S1 - P1 / Motor**

**Reducer Model**

EVL070, EVL090, EVL120  
EVL145, EVL180

**Output Shaft Keyway**

S1: (Solid Output Shaft No Keyway)  
S2: Standard (Keyway)  
S3: Output for holes

**Motor Model**

Motor Manufacturer & Model

**Ratio**

1-stage: 3, 4, 5, 6, 7, 8, 9, 10  
2-stage: 15, 20, 25, 30, 35, 40, 45, 50,  
60, 70, 80, 90, 100

**Backlash Grade**

P0: High precision backlash  
P1: Precision backlash  
P2: Standard backlash

The gearbox matching motor needs to be confirmed with following dimensions :

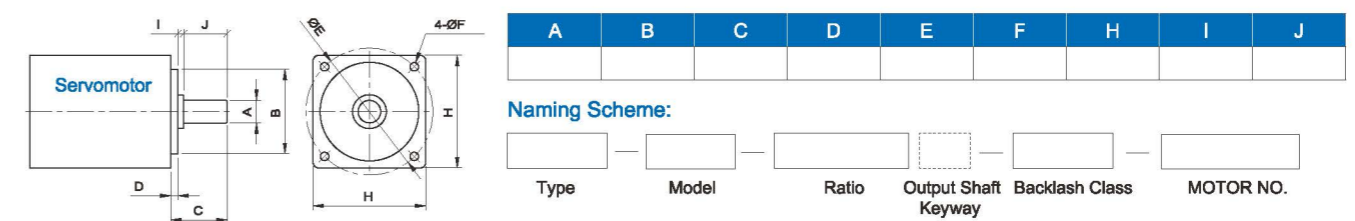

# EVL Reducer Specifications

Specs	Unit	Stage	Ratio	EVL070	EVL090	EVL120	EVL145	EVL180
Rated Output Torque / T2N	Nm	1	3	45	130	230	450	900
			4	50	140	290	542	1050
			5	60	160	330	650	1200
			6	55	150	310	600	1100
			7	50	140	300	550	1100
			8	45	120	260	500	1000
			9	40	100	230	450	900
			10	40	100	208	342	588
			14	45	130	230	450	900
			20	50	140	290	542	1050
		2	15	60	160	330	650	1200
			20	55	150	310	600	1100
			25	60	160	330	550	1100
			30	45	120	260	500	1000
			35	40	100	230	450	900
			40	60	160	330	650	1200
			50	50	140	300	550	1100
			70	45	120	260	500	1000
			80	40	100	230	450	900
			100	40	100	208	342	588
120	—	128	305	495	1095			
140	—	128	295	525	1095			
160	—	118	255	515	995			
180	—	98	225	445	895			
200	—	98	225	445	895			
Max. Output Torque / T2NOT <sup>1</sup>	Nm	1,2	3~200	3Times of Nominal Output Torque				
Rated Input Speed / Π <sub>IN</sub>	rpm	1,2	3~200	3000	3000	3000	2500	2000
Max. Input Speed / Π <sub>IS</sub>	rpm	1,2	3~200	6000	6000	5500	4500	4500
Precision Backlash P0	arcmin	1	3~20	≤2	≤2	≤2	≤2	≤2
		2	15~200	≤4	≤4	≤4	≤4	≤4
Precision Backlash P1	arcmin	1	3~20	≤4	≤4	≤4	≤4	≤4
		2	15~200	≤6	≤6	≤6	≤6	≤6
Standard Backlash P2	arcmin	1	3~20	≤6	≤6	≤6	≤6	≤6
		2	15~200	≤8	≤8	≤8	≤8	≤8
Torsional Rigidity	Nm/arcmin	1,2	3~200	6	14	25	56	140
Max. Radial Force / F <sub>2B</sub> <sup>2</sup>	N	1,2	3~200	1300	3200	6750	9400	14500
Max. Axial Force / F <sub>2A1B</sub> <sup>2</sup>	N	1,2	3~200	700	1580	3300	4700	7200
Service Life	hr	1,2	3~200	21000 h				
		1	3~20	≥93%				
Efficiency / η	%	2	25~200	≥90%				
		1	3~20	1.5	6.4	13	24.5	51
Weight	kg	2	25~200	2.1	7.8	14.2	27.5	54
		1,2	3~200	(-15°C ~ +90°C)				
Lubrication		1,2	3~200	(Synthetic Grease)				
Protection Class		1,2	3~200	IP65				
Mounting Position		1,2	3~200	(Any Direction)				
Noise Level (n1=3000rpm, No load)	dB(A)	1,2	3~200	≤65	≤68	≤68	≤70	≤72

## Reducer Rotary Inertia

Specs	Unit	Stage	Ratio	EVL070	EVL090	EVL120	EVL145	EVL180
Moment of Inertia	kg.cm <sup>2</sup>	1	3~10	0.35	2.25	6.84	23.4	68.9
			14~20	0.07	1.87	6.25	21.8	65.6
		2	15~100	0.09	0.35	2.25	6.84	23.4
			120~200	—	0.31	1.87	6.25	21.8

1. The Max. acceleration torque T2B=60% of T2NOT 2. When output speed is 100rpm, inertia acts on the output shaft center position.  
3. 3-stage big ratios are not in the above table. There is shaft lengthening and enlarging design. Please tell sales person if you need it.

# MODEL: EVL

1-Stage

Ratio: 3, 4, 5, 6, 7, 8, 9, 10



## Dimensions:

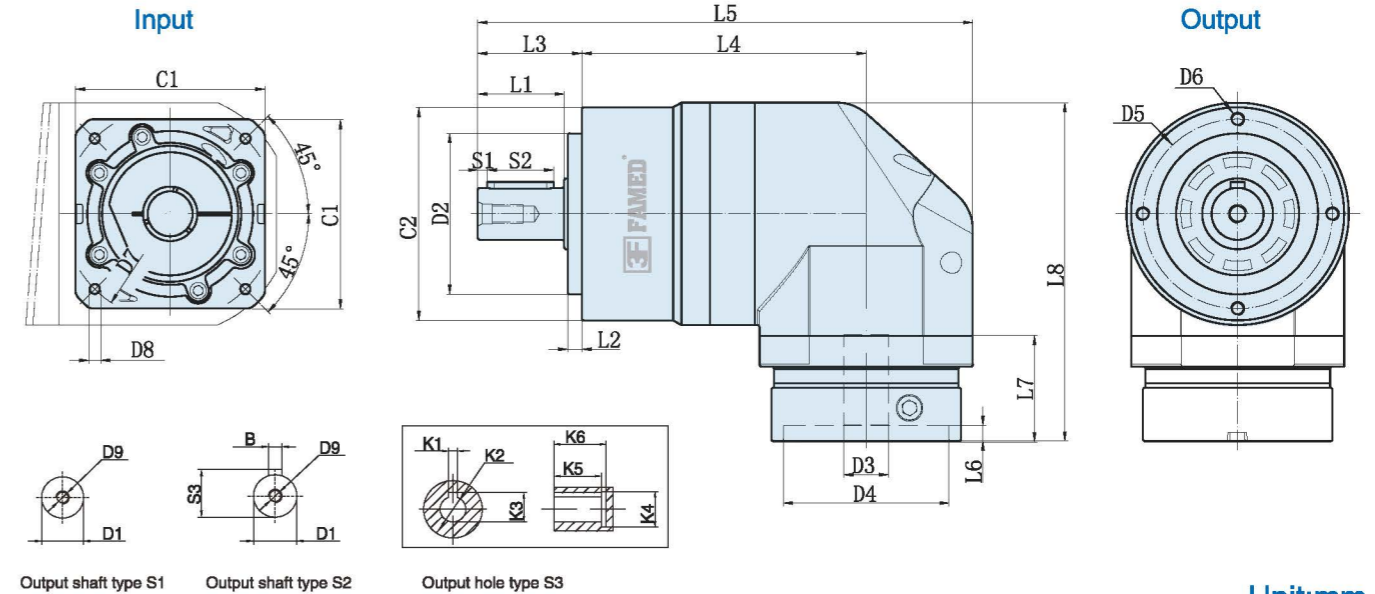

Unit:mm

Size	EVL070-L1	EVL090-L1	EVL120-L1	EVL145-L1	EVL180-L1
D1	φ 16	φ 22	φ 32	φ 40	φ 55
D2	φ 52	φ 68	φ 90	φ 120	φ 160
D3	φ 14 ( ≤19 )	φ 19(11~24)	φ 24(16~24)	φ 24 ( ≤42 )	φ 35 ( ≤55 )
D4	φ 50 ( 50~70 )	φ 70 ( 50~110 )	φ 110 ( 50~110 )	φ 110 ( ≤180 )	φ 114.3 ( ≤180 )
D5	φ 62	φ 80	φ 108	φ 140	φ 184
D6	4-M5*10	4-M6*12	4-M8*16	4-M10*20L	4-M12*30L
D7	φ 70 ( 70~130 )	φ 90 ( 70~145 )	φ 145 ( 90~155 )	φ 145 ( ≤215 )	φ 200 ( ≤300 )
D8	( 4-M4*10L)	( 4-M5*12L)	( 4-M8*20L)	( 4-M12*30L)	( 4-M12*30L)
D9	M5*0.8P*15L	M6*1.25P*19L	M12*1.75P*28L	M16*36L	M20*42L
L1	28.5	36.5	51	97	100
L2	5	6	9	79	84
L3	35	44	62	15	15
L4	88	120	140.5	172	294
L5	153	209	260	340	365
L6	(5)	(6.5)	(10)	(10)	(19)
L7	(33)	(45)	(64)	(84)	(81)
L8	(112.50)	(143)	(195.5)	(238)	(278)
C1	( □60 )	( □80 )	( □130 )	( □130 )	( □180 )
C2	φ 70	φ 90	φ 120	φ 155	φ 205
S1	3	4	5	5	6
S2	22	28	40	63	70
S3	18	24.5	35	43	59
B	5	6	10	12	16
K1	4	6	8	10	14
K2	φ 11	φ 22	φ 28	φ 38	φ 50
K3	12.8	24.5	31.3	42	53.8
K4	φ 16	φ 32	φ 38	φ 48	φ 60
K5	15	20	27	35	43
K6	18	24	32	40	50

Note 1: Inside of ( ) is the optional range of sizes, outside of ( ) is the standard sizes.  
Note 2: The reducer output shaft size and length can be customized for customers.  
Note 3: The input size can be changed according to the servomotor or stepper motor of each brand.

# MODEL: EVL

2-Stage

Ratio: 15, 20, 25, 30, 35, 40, 45, 50,  
60, 70, 80, 90, 100



## Dimensions:

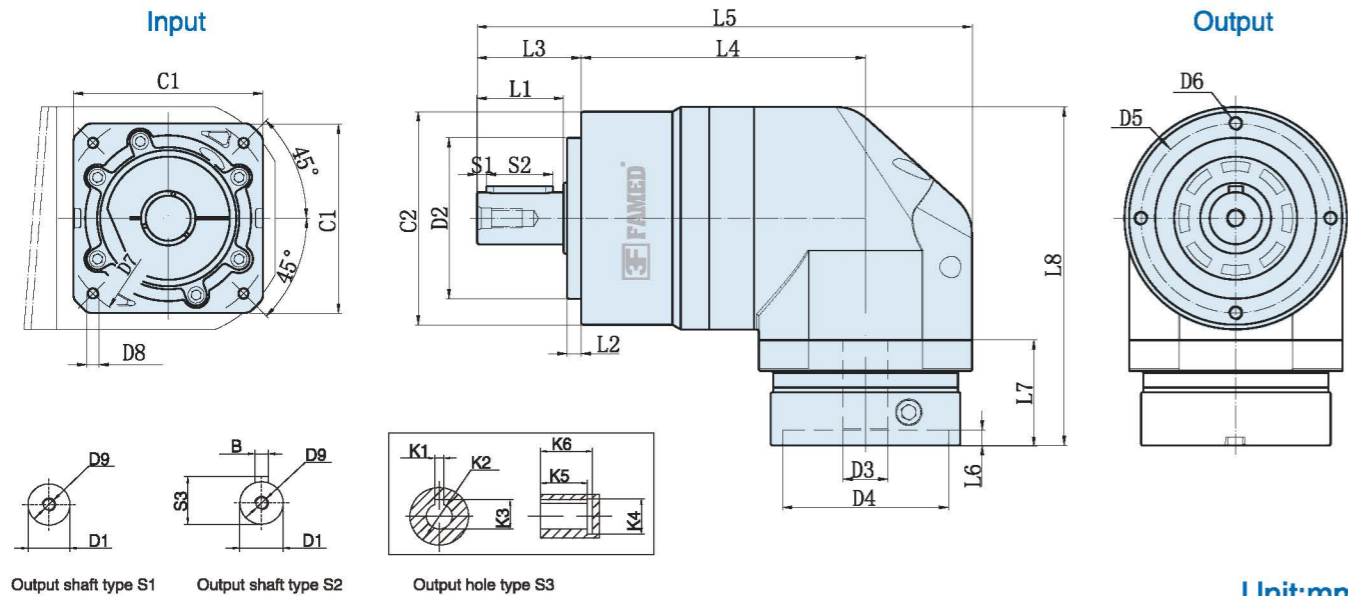

Unit:mm

Size	EVL070-L2	EVL090-L2	EVL120-L2	EVL145-L2	EVL180-L2
D1	φ 16	φ 22	φ 32	φ 40	φ 55
D2	φ 52	φ 68	φ 90	φ 120	φ 160
D3	φ 14 ( ≤19 )	φ 19(11-24)	φ 24(16-24)	φ 24 ( ≤42 )	φ 35 ( ≤55 )
D4	φ 50 ( 50-70 )	φ 70 ( 50-110 )	φ 110 ( 50-110 )	φ 110 ( ≤180 )	φ 114.3 ( ≤180 )
D5	φ 62	φ 80	φ 108	φ 140	φ 184
D6	4-M5*10	4-M6*12	4-M8*16	4-M10*20L	4-M12*30L
D7	φ 70 ( 70-130 )	φ 90 ( 70-145 )	φ 145 ( 90-155 )	φ 145 ( ≤215 )	φ 200 ( ≤300 )
D8	( 4-M4*10L)	( 4-M5*12L)	( 4-M8*20L)	( 4-M12*30L)	( 4-M12*30L)
D9	M5*0.8P*15L	M6*1.25P*19L	M12*1.75P*28L	M16*36L	M20*42L
L1	28.5	36.5	51	97	100
L2	5	6	9	79	84
L3	35	44	62	15	15
L4	117	134.5	170.5	233	362.5
L5	182	208.5	277.5	401	433.5
L6	(5)	(6.5)	(10)	(10)	(19)
L7	(33)	(42.5)	(59)	(84)	(81)
L8	(112.50)	(134)	(180)	(238)	(278)
C1	( □60 )	( □80 )	( □130 )	( □130 )	( □180 )
C2	φ 70	φ 90	φ 120	φ 155	φ 205
S1	3	4	5	5	6
S2	22	28	40	63	70
S3	18	24.5	35	43	59
B	5	6	10	12	16
K1	4	6	8	10	14
K2	φ 11	φ 22	φ 28	φ 38	φ 50
K3	12.8	24.5	31.3	42	53.8
K4	φ 16	φ 32	φ 38	φ 48	φ 60
K5	15	20	27	35	43
K6	18	24	32	40	50

Note 1: Inside of ( ) is the optional range of sizes, outside of ( ) is the standard sizes.  
 Note 2: The reducer output shaft size and length can be customized for customers.  
 Note 3: The input size can be changed according to the servomotor or stepper motor of each brand.

# High Precision Flange Output Planetary Gearbox

## VRT

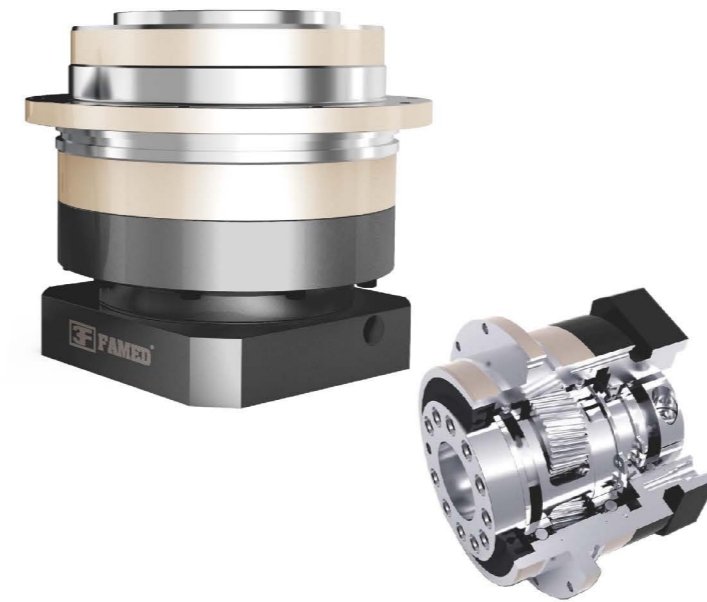

- 1. Quiet operation  
Helical gears are used to achieve smooth and quiet operation.
- 2. High precision  
The backlash is less than 3 arcmin and the positioning is accurate.
- 3. High rigidity & torque  
The use of integral ball bearings greatly improves the rigidity and torque.
- 4. Methods of flange and connector  
It can be installed on any motor in the world.
- 5. No grease leakage  
The use of grease with high viscosity which is not easy to separate effectively prevents the grease leakage.
- 6. Convenient maintenance  
No need to replace the grease in the product life period, and the installation is more convenient.

## Model Selection of Speed Reducers

**VRT Type**

VRT090 - 10 - S1 - P1 / Motor

**Reducer Model**

VRT047, VRT064, VRT090, VRT110  
VRT140, VRT200, VRT255

**Output flange mode**

S1: Standard flange face output  
S2: Non standard flange face output

**Motor Model**

Motor Manufacturer & Model

**Ratio**

1-stage: 3, 4, 5, 6, 7, 8, 9, 10  
2-stage: 12, 15, 16, 20, 25, 28, 30, 35,  
40, 50, 70, 80, 100

**Backlash Grade**

P0: High precision backlash  
P1: Precision backlash  
P2: Standard backlash

The gearbox matching motor needs to be confirmed with following dimensions :

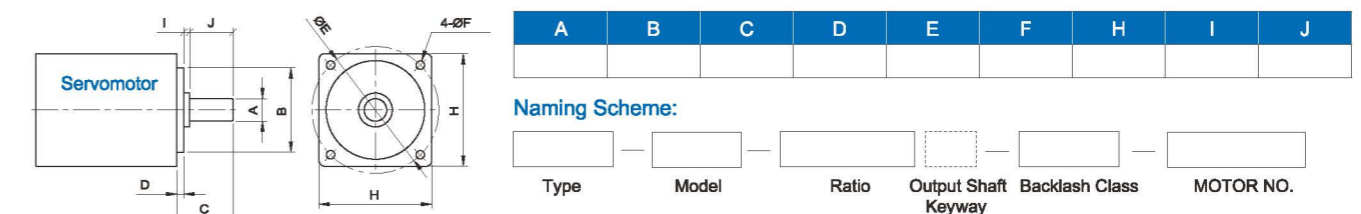

## VRT Reducer Specifications

Specs	Unit	Stage	Ratio	VRT047	VRT064	VRT090	VRT110	VRT140	VRT200	VRT255
Rated Output Torque / T2N	Nm	1	4	19	50	133	278	555	1050	1700
			5	22	60	160	330	650	1200	2000
			7	19	50	140	300	550	1100	1800
			10	14	40	100	230	450	900	1500
		2	20	19	50	133	278	555	1050	1700
			25	22	60	160	330	650	1200	2000
			35	19	50	140	300	550	1100	1800
			40	19	45	120	260	500	1000	1600
			50	22	60	160	330	650	1200	2000
			70	19	50	140	300	550	1100	1800
100	14	40	100	230	450	900	1500			
Max.Output Torque / T2NOT <sup>1</sup>	Nm	1,2	4~100	3Times of Nominal Output Torque						
Rated Input Speed / Π1N	rpm	1,2	4~100	5000	5000	4000	4000	3000	3000	2000
Max.Input Speed / Π1B	rpm	1,2	4~100	10000	10000	8000	8000	6000	6000	4000
Micro Backlash P0	arcmin	1	4~10	≤1	≤1	≤1	≤1	≤1	≤1	≤1
Precision Backlash P1	arcmin	2	12~100	≤3	≤3	≤3	≤3	≤3	≤3	≤3
		1	4~10	≤3	≤3	≤3	≤3	≤3	≤3	≤3
Standard Backlash P2	arcmin	2	20~100	≤5	≤5	≤5	≤5	≤5	≤5	≤5
		1	4~10	≤5	≤5	≤5	≤5	≤5	≤5	≤5
Torsional Rigidity	Nm/arcmin	1,2	4~100	8	13	30	80	150	450	1010
Max.Radial Force / F2a <sup>2</sup>	N	1,2	4~100	43	125	235	430	1300	3064	5900
Max.Axial Force / F2a1a <sup>2</sup>	N	1,2	4~100	990	1050	2850	2990	10590	16660	29430
Service Life	hr	1,2	4~100	22000h						
Efficiency / η	%	1	4~10	≥97%						
		2	20~100	≥94%						
Weight	kg	1	4~10	0.7	1.3	3.2	5.8	12.3	33	57.9
		2	20~100	1	1.5	4.1	7.6	16.8	38	72.6
Operating Temperature	°C	1,2	4~100	(-15°C ~ +90°C)						
Lubrication		1,2	4~100	(Synthetic Grease)						
Protection Class		1,2	4~100	IP65						
Mounting Position		1,2	4~100	(Any Direction)						
Noise Level (n1=3000rpm, No load)	dB(A)	1,2	4~100	≤56	≤58	≤60	≤63	≤65	≤67	≤70

## Reducer Rotary Inertia

Specs	Unit	Stage	Ratio	VRT047	VRT064	VRT090	VRT110	VRT140	VRT200	VRT255
Moment of Inertia	kg.cm <sup>2</sup>	1	4	0.03	0.14	0.48	2.74	7.54	23.67	54.37
			5	0.03	0.13	0.47	2.71	7.42	23.29	53.27
			7	0.03	0.13	0.45	2.62	7.14	22.48	50.97
			10	0.03	0.13	0.44	2.57	7.03	22.51	50.56
		2	20~40	0.03	0.03	0.13	0.47	2.71	7.42	23.29
			50~100	0.03	0.03	0.13	0.44	2.57	7.03	22.51

1. Max. reduction ratio(i=Nin/Nout) 2.The Max. acceleration torque T2B=60% of T2NOT  
3. When output speed is 100rpm, acting on the output shaft center position, \*Continuous operation, service life is 15000hrs.

## MODEL: VRT

1-Stage

Ratio: 3, 4, 5, 6, 7, 8, 9, 10

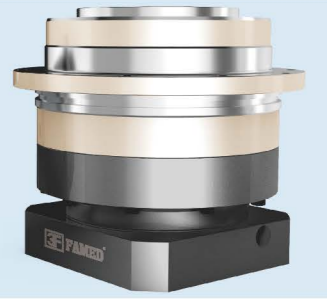

### Dimensions:

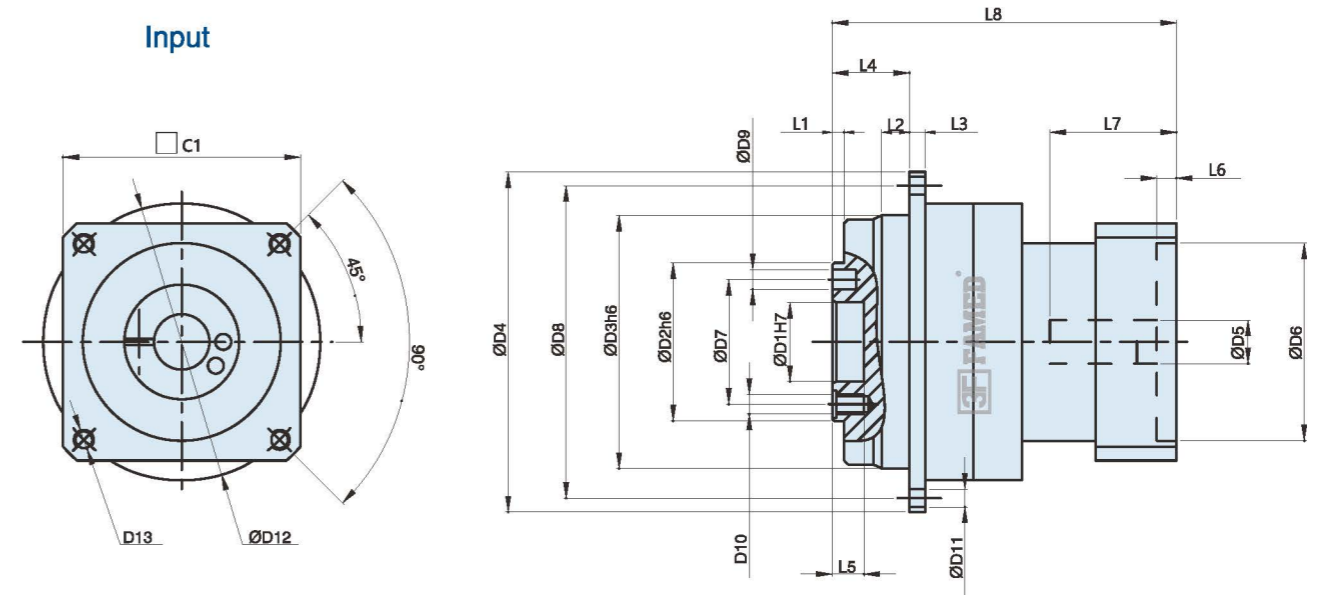

Unit:mm

Size	VRT047-L1	VRT064-L1	VRT090-L1	VRT110-L1	VRT140-L1	VRT200-L1	PAD255-L1
D1	12	20	31.5	40	50	80	100
D2	28	40	63	80	100	160	180
D3	47	64	90	110	140	200	255
D4	72	86	118	145	179	247	300
D5	≤11/≤12	11(8~14)	19(14~22)	24(22~28)	24(24~48)	35(35~48)	48(48~55)
D6	30	30(30~50)	50(50~110)	110	110(110~114.3)	114.3(114.3~200)	200
D7	20	31.5	50	63	80	125	140
D8	67	79	109	135	168	233	280
D9	Ø3	Ø5x深度(D)8	Ø6x深度(D)7	Ø6x深度(D)7	Ø8x深度(D)7	Ø10x深度(D)10	Ø12x深度(D)10
D10	4-M3	7-M5x深度(D)8	8-M6x深度(D)12	11-M6x深度(D)12	11-M8x深度(D)17	11-M10x深度(D)20	12-M16x深度(D)25
D11	8-Ø3.4	8-Ø4.5	8-Ø5.5	8-Ø5.5	12-Ø6.6	12-Ø9	16-Ø13.5
D12	46	45(45~70)	70(70~145)	145	145(145~200)	200(200~235)	235
D13	M4	M4~M5	M5~M8	M8	M8~M12	M12	M12
L1	3	3	6	6	6	8	12
L2	7	7	10	10	14.5	15	21.5
L3	4	4	7	8	10	12	18
L4	19.5	19.5	30	29	38	50	66
L5	4	8	12	13	12	16	20
L6	3.5	4~5	5~10	10	6~8	6~10	10
L7	30	28(28~34)	32(32~59)	60	73(73~115)	88(88~117)	119.5
L8	70	80.5~87	97(97~120)	142	159(159~201)	196(196~229)	255
C1	48	60(40~60)	90(60~130)	130	130(130~180)	180(180~220)	220

- Note 1: Inside of ( ) is the optional range of sizes, outside of ( ) is the standard sizes.  
Note 2: The reducer output shaft size and length can be customized for customers.  
Note 3: The input size can be changed according to the servomotor or stepper motor of each brand.

# MODEL: VRT

2-Stage

Ratio: 12, 15, 16, 20, 25, 28, 30, 35  
40, 50, 70, 80, 100

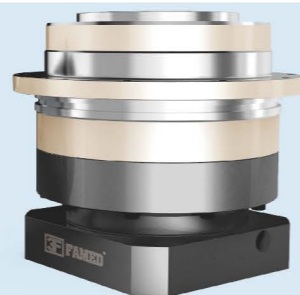

# MODEL: VRT

Output Dimensions:

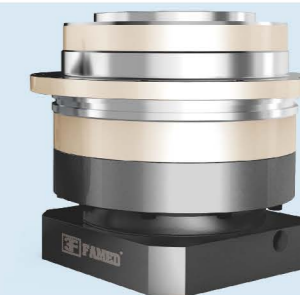

Dimensions:

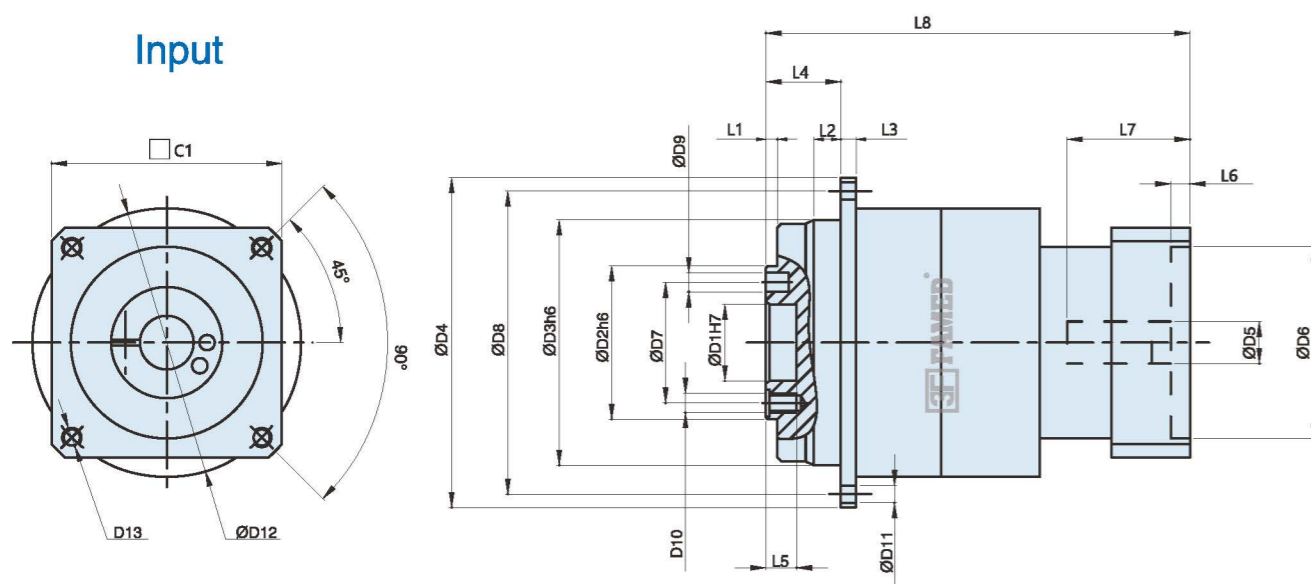

Unit:mm

Size	VRT047-L2	VRT064-L2	VRT090-L2	VRT110-L2	VRT140-L2	VRT200-L2	VRT255-L2
D1	12	20	31.5	40	50	80	100
D2	28	40	63	80	100	160	180
D3	47	64	90	110	140	200	255
D4	72	86	118	145	179	247	300
D5	≤11/≤12	11(8 ~ 14)	19(14 ~ 22)	19(22 ~ 28)	19(19 ~ 38)	35(24 ~ 48)	38(38 ~ 55)
D6	30	30(30 ~ 50)	50(50 ~ 110)	70(70 ~ 110)	70(70 ~ 114.3)	110(110 ~ 200)	114.3(114.3 ~ 200)
D7	20	31.5	50	63	80	125	140
D8	67	79	109	135	168	233	280
D9	Ø3	Ø5x深度(D)8	Ø6x深度(D)7	Ø6x深度(D)7	Ø8x深度(D)7	Ø10x深度(D)10	Ø12x深度(D)10
D10	4-M3	7-M5x深度(D)8	8-M6x深度(D)12	11-M6x深度(D)12	11-M8x深度(D)17	11-M10x深度(D)20	12-M16x深度(D)25
D11	8-Ø3.4	8-Ø4.5	8-Ø5.5	8-Ø5.5	12-Ø6.6	12-Ø9	16-Ø13.5
D12	46	45(45 ~ 70)	70(70 ~ 145)	90(90 ~ 145)	90(90 ~ 200)	145(145 ~ 235)	200(200 ~ 235)
D13	M4	M4 ~ M5	M5 ~ M8	M6 ~ M8	M5 ~ M12	M8 ~ M12	M12
L1	3	3	6	6	6	8	12
L2	7	7	10	10	14.5	15	20
L3	4	4	7	8	10	12	18
L4	19.5	19.5	30	29	38	50	66
L5	4	8	12	13	12	16	20
L6	3.5	4 ~ 5	5 ~ 10	6 ~ 10	6 ~ 8	6 ~ 10	6 ~ 10
L7	30	28(28 ~ 34)	34(34 ~ 59)	43(43 ~ 60)	65(65 ~ 85)	73(73 ~ 117)	73(73 ~ 117)
L8	97.5	103(103 ~ 110)	123(123 ~ 139)	150(150 ~ 176)	195(195 ~ 211)	292(292 ~ 336)	306(306 ~ 322)
C1	48	60(40 ~ 60)	90(60 ~ 130)	90(90 ~ 130)	90(90 ~ 180)	180(130 ~ 220)	180(180 ~ 220)

Note 1: Inside of ( ) is the optional range of sizes, outside of ( ) is the standard sizes.

Note 2: The reducer output shaft size and length can be customized for customers.

Note 3: The input size can be changed according to the servomotor or stepper motor of each brand.

VRT047 OUTPUT

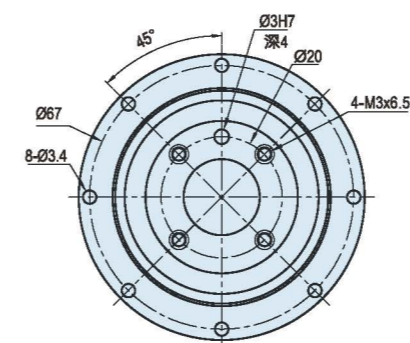

VRT064 OUTPUT

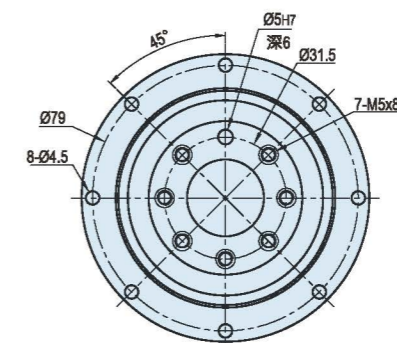

VRT090 OUTPUT

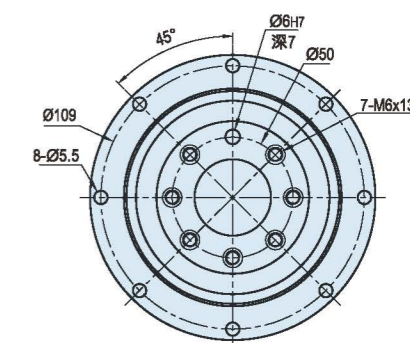

VRT110 OUTPUT

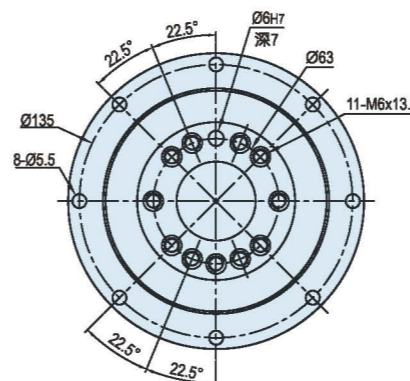

VRT140 OUTPUT

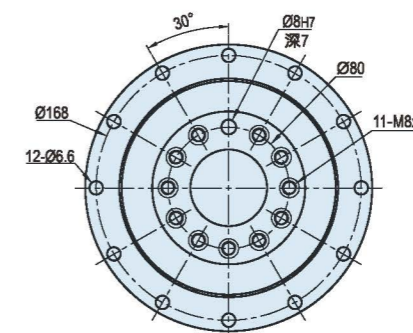

VRT200 OUTPUT

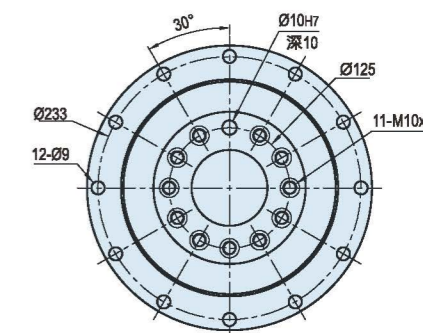

VRT255 OUTPUT

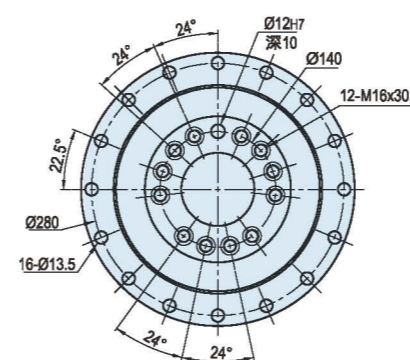

# High Precision Flange Output Right Angle Planetary Gearbox

## EVT



- 1. Quiet operation**  
 Helical gears are used to achieve smooth and quiet operation.
- 2. High precision**  
 The backlash is less than 3 arcmin and the positioning is accurate.
- 3. High rigidity & torque**  
 The use of integral ball bearings greatly improves the rigidity and torque.
- 4. Methods of flange and connector**  
 It can be installed on any motor in the world.
- 5. No grease leakage**  
 The use of grease with high viscosity which is not easy to separate effectively prevents the grease leakage.
- 6. Convenient maintenance**  
 No need to replace the grease in the product life period, and the installation is more convenient.

## Model Selection of Speed Reducers

### EVT Type

**EVT090**

**Reducer Model**

EVT047, EVT064, EVT090  
EVT110, EVT140, EVT200  
EVT255

**10**

**Ratio**

1-stage: 3, 4, 5, 6, 7, 8, 9, 10  
2-stage: 12, 15, 16, 20, 25, 28, 30, 35, 40, 50, 70, 80, 100

**S1**

**Output flange mode**

S1: Standard flange face output  
S2: Non standard flange face output

**P1**

**Backlash Grade**

P0: High precision backlash  
P1: Precision backlash  
P2: Standard backlash

**Motor**

**Motor Model**

Motor Manufacturer & Model

The gearbox matching motor needs to be confirmed with following dimensions :

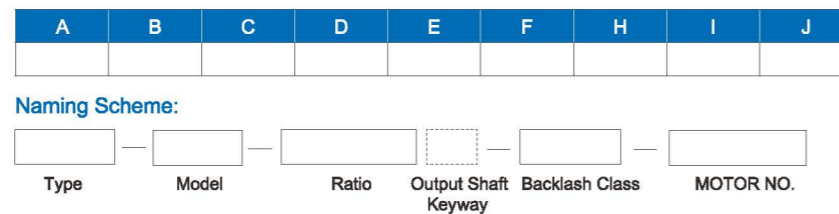
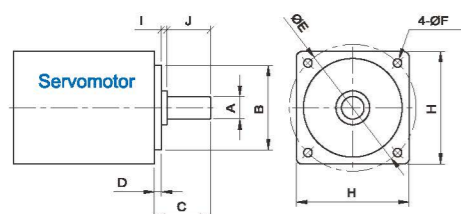

## EVT Reducer Specifications

Specs	Unit	Stage	Ratio	EVT047	EVT064	EVT090	EVT110	EVT140	EVT200	EVT255
Rated Output Torque / T <sub>2N</sub>	Nm	1	4	19	50	133	278	555	1050	1700
			5	22	60	160	330	650	1200	2000
			7	19	50	140	300	550	1100	1800
			10	14	40	100	230	450	900	1500
		2	20	19	50	133	278	555	1050	1700
			25	22	60	160	330	650	1200	2000
			35	19	50	140	300	550	1100	1800
			40	19	45	120	260	500	1000	1600
			50	22	60	160	330	650	1200	2000
			70	19	50	140	300	550	1100	1800
100	14	40	100	230	450	900	1500			
Max. Output Torque / T <sub>2NOT</sub> <sup>1</sup>	Nm	1,2	4~100	3Times of Nominal Output Torque						
Rated Input Speed / n <sub>1N</sub>	rpm	1,2	4~100	5000	5000	4000	4000	3000	3000	2000
Max. Input Speed / n <sub>1B</sub>	rpm	1,2	4~100	10000	10000	8000	8000	6000	6000	4000
Micro Backlash P0	arcmin	1	4~10	≤2	≤2	≤2	≤2	≤2	≤2	≤2
		2	12~100	≤4	≤4	≤4	≤4	≤4	≤4	≤4
Precision Backlash P1	arcmin	1	4~10	≤4	≤4	≤4	≤4	≤4	≤4	≤4
		2	20~100	≤6	≤6	≤6	≤6	≤6	≤6	≤6
Standard Backlash P2	arcmin	1	4~10	≤6	≤6	≤6	≤6	≤6	≤6	≤6
		2	20~100	≤8	≤8	≤8	≤8	≤8	≤8	≤8
Torsional Rigidity	Nm/arcmin	1,2	4~100	8	13	30	80	150	450	1010
Max. Radial Force / F <sub>2B</sub> <sup>2</sup>	N	1,2	4~100	43	125	235	430	1300	3064	5900
Max. Axial Force / F <sub>2A</sub> <sup>2</sup>	N	1,2	4~100	990	1050	2850	2990	10590	16660	29430
Service Life	hr	1,2	4~100	22000h						
Efficiency / η	%	1	4~10	≥97%						
		2	20~100	≥94%						
Weight	kg	1	4~10	0.7	1.3	3.2	5.8	12.3	33	57.9
		2	20~100	1	1.5	4.1	7.6	16.8	38	72.6
Operating Temperature	℃	1,2	4~100	(-15℃ ~ +90℃)						
Lubrication		1,2	4~100	(Synthetic Grease)						
Protection Class		1,2	4~100	IP65						
Mounting Position		1,2	4~100	(Any Direction)						
Noise Level (n1=3000rpm, No load)	dB(A)	1,2	4~100	≤58	≤59	≤62	≤65	≤68	≤69	≤70

## Reducer Rotary Inertia

Specs	Unit	Stage	Ratio	EVT047	EVT064	EVT090	EVT110	EVT140	EVT200	EVT255
Moment of Inertia	kg.cm <sup>2</sup>	1	4	0.03	0.14	0.48	2.74	7.54	23.67	54.37
			5	0.03	0.13	0.47	2.71	7.42	23.29	53.27
			7	0.03	0.13	0.45	2.62	7.14	22.48	50.97
			10	0.03	0.13	0.44	2.57	7.03	22.51	50.56
		2	20~40	0.03	0.03	0.13	0.47	2.71	7.42	23.29
			50~100	0.03	0.03	0.13	0.44	2.57	7.03	22.51

- Ratio (i=N<sub>in</sub>/N<sub>out</sub>) .
- The Max. acceleration torque T<sub>2B</sub>=60% of T<sub>2NOT</sub>.
- When output speed is 100rpm, acting on the output shaft center position \*Continuous operation, service life is 15000hrs.

# MODEL: EVT

1-Stage

Ratio: 3, 4, 5, 6, 7, 8, 9, 10



Dimensions:

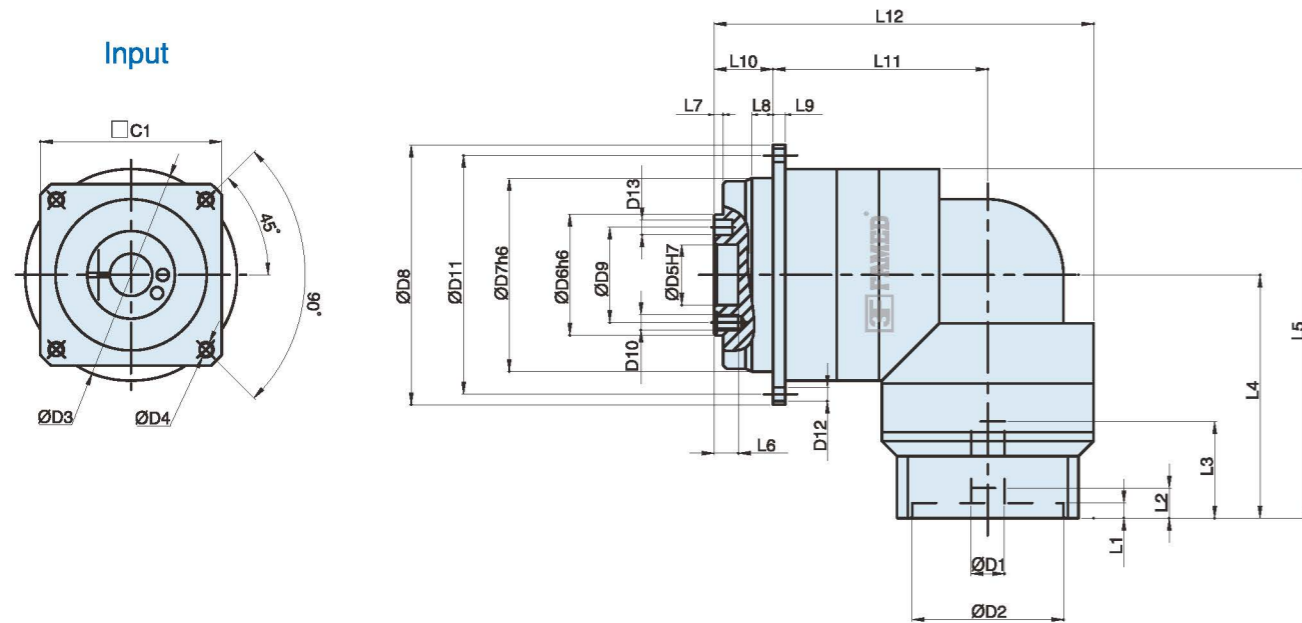

Unit:mm

Size	EVT047-L1	EVT064-L1	EVT090-L1	EVT110-L1	EVT140-L1	EVT200-L1	EVT255-L1
D1	≤11/≤12	11(11 ~ 14)	19(19 ~ 24)	24(22 ~ 32)	32(24 ~ 35)	≤48	≤55
D2	30	50	70(70 ~ 110)	110(110 ~ 130)	110(110 ~ 114.3)	85	116
D3	46	70	90(90 ~ 145)	145(145 ~ 165)	145(145 ~ 200)	215	235
D4	M4	M4	M8	M8 ~ M10	M8 ~ M12	M12	M12
D5	12	20	31.5	40	50	80	100
D6	28	40	63	80	100	160	180
D7	47	64	90	110	140	200	255
D8	72	86	118	145	179	247	300
D9	20	31.5	50	63	80	125	140
D10	4-M3	7-M5x深度(D)8	8-M6x深度(D)12	11-M6x深度(D)12	11-M8x深度(D)17	11-M10x深度(D)20	12-M16x深度(D)25
D11	67	79	109	135	168	233	280
D12	8-Ø3.4	8-Ø4.5	8-Ø5.5	8-Ø5.5	12-Ø6.6	12-Ø9	16-Ø13.5
D13	Ø3	Ø5x深度(D)8	Ø6x深度(D)7	Ø6x深度(D)7	Ø8x深度(D)7	Ø10x深度(D)10	Ø12x深度(D)10
L1	3.5	5	12	10	8	6	6
L2	8	10	13	19	17	20	24
L3	30	32	42 ~ 47	57 ~ 60	67 ~ 77	85	116
L4	74	80.5	107 ~ 112	134 ~ 147.5	166.5 ~ 167	213.5	268.5
L5	104	115.5	152 ~ 157	195 ~ 208.5	217.5 ~ 241.5	316	398.5
L6	6.5	8	12	13	12	22.5	30.5
L7	3	3	6	6	6	8	12
L8	7	7	10	11	15	15	20
L9	4	4	7	8	10	12	18
L10	19.5	19.5	25	29	38	50	66
L11	60	71	102	130	142.5	189	216
L12	107.5	125.5	172	220	255.5	334.5	392
C1	48	60	90(90 ~ 130)	130 ~ 160	130(130 ~ 220)	190	220

# MODEL: EVT

2-Stage

Ratio: 12, 15, 16, 20, 25, 28, 30, 35  
40, 50, 70, 80, 100



Dimensions:

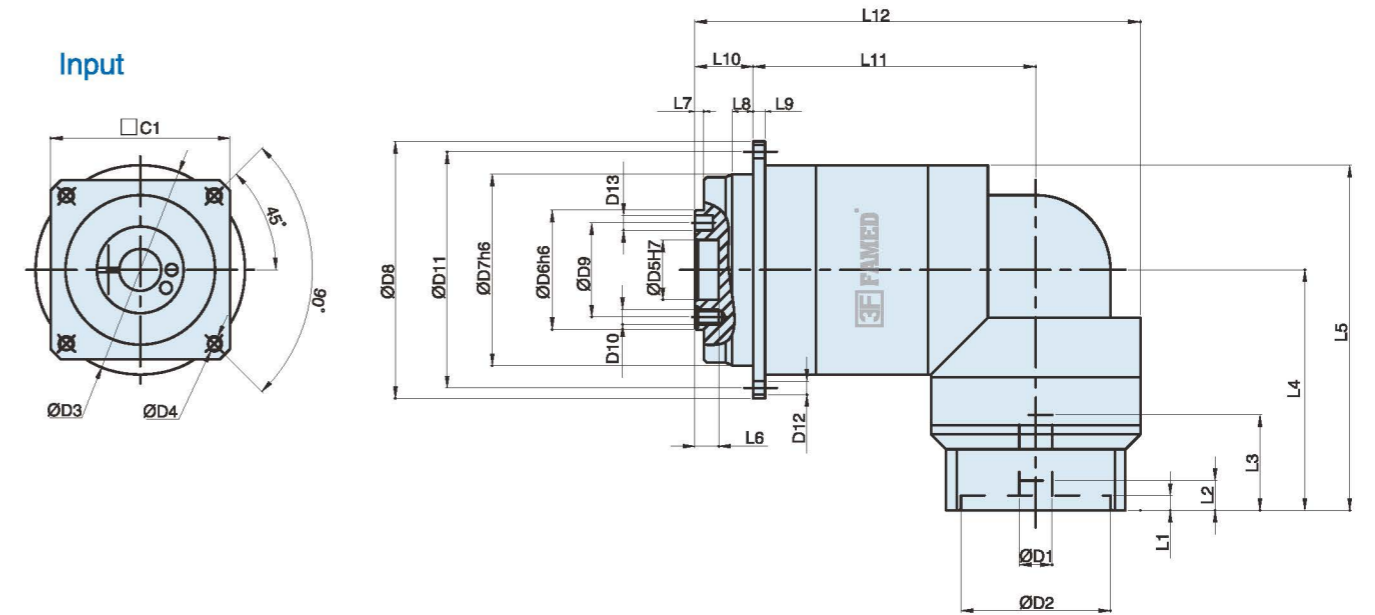

Unit:mm

Size	EVT47-L2	EVT064-L2	EVT090-L2	EVT110-L2	EVT140-L2	EVT200-L2	EVT255-L2
D1	≤11/≤12	11(11 ~ 14)	19(19 ~ 24)	24(22 ~ 32)	32(24 ~ 35)	≤48	≤55
D2	30	50	70(70 ~ 110)	110(110 ~ 130)	110(110 ~ 114.3)	85	116
D3	46	70	90(90 ~ 145)	145(145 ~ 165)	145(145 ~ 200)	215	235
D4	M4	M4	M8	M8 ~ M10	M8 ~ M12	M12	M12
D5	12	20	31.5	40	50	80	100
D6	28	40	63	80	100	160	180
D7	47	64	90	110	140	200	255
D8	72	86	118	145	179	247	300
D9	20	31.5	50	63	80	125	140
D10	4-M3	7-M5x深度(D)8	8-M6x深度(D)12	11-M6x深度(D)12	11-M8x深度(D)17	11-M10x深度(D)20	12-M16x深度(D)25
D11	67	79	109	135	168	233	280
D12	8-Ø3.4	8-Ø4.5	8-Ø5.5	8-Ø5.5	12-Ø6.6	12-Ø9	16-Ø13.5
D13	Ø3	Ø5x深度(D)8	Ø6x深度(D)7	Ø6x深度(D)7	Ø8x深度(D)7	Ø10x深度(D)10	Ø12x深度(D)10
L1	3.5	5	12	10	8	6	6
L2	8	10	13	19	17	20	24
L3	30	32	42 ~ 47	57 ~ 60	67 ~ 77	85	116
L4	74	80.5	107 ~ 112	134 ~ 147.5	166.5 ~ 167	213.5	268.5
L5	103	115.5	152 ~ 157	195 ~ 208.5	217.5 ~ 241.5	269.5	340
L6	4	8	12	13	12	22.5	30.5
L7	3	3	6	6	6	8	12
L8	7	7	10	11	15	15	20
L9	4	4	7	8	10	12	18
L10	19.5	19.5	30	29	38	50	66
L11	79	94.5	117	163.5	187	243	270
L12	122	149	187	253.5	300	382	403
C1	48	60	90(90 ~ 130)	130 ~ 160	130(130 ~ 220)	190	220

# MODEL: EVT

## Output Dimensions

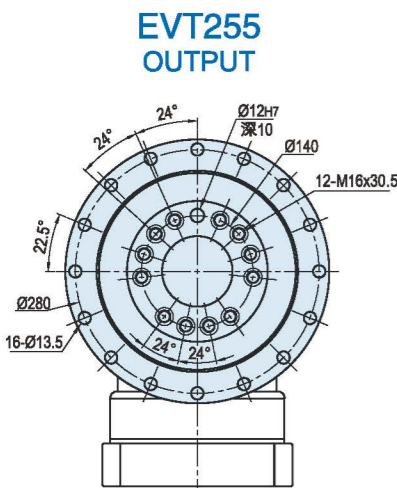
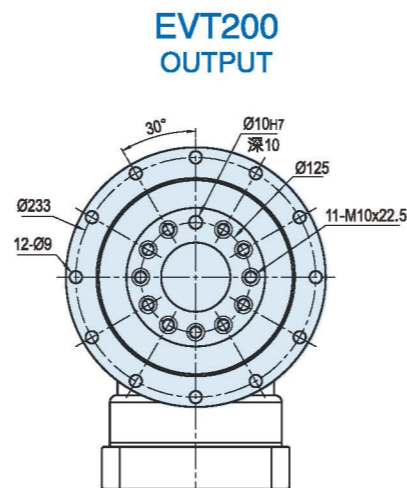
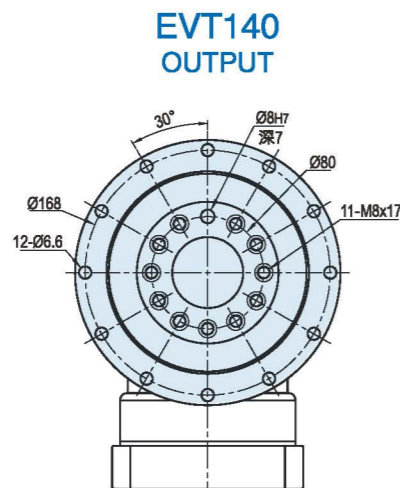
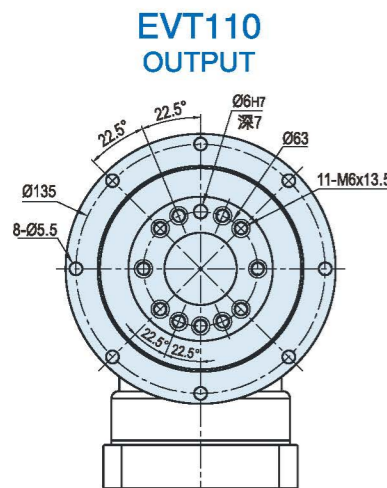
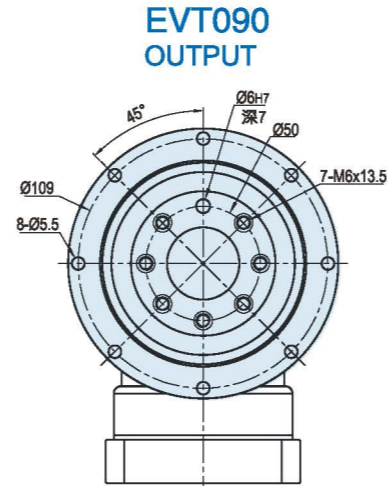
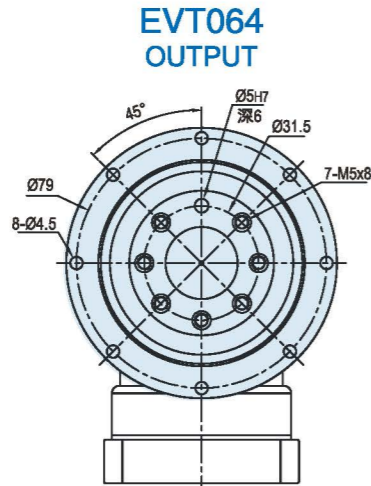
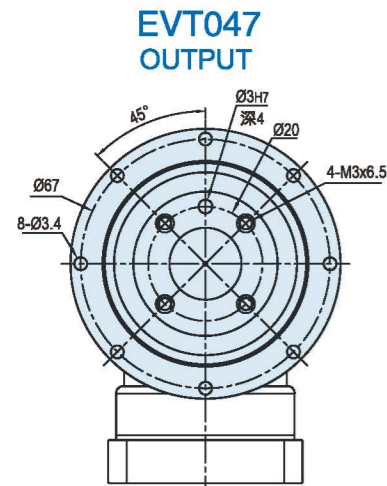

# European High Precision High Torque Planetary Gearbox

## VRS



- 1. High precision  
The backlash is less than 3 arcmin and the positioning is accurate.
- 2. High rigidity & torque  
The use of integral ball bearings greatly improves the rigidity and torque.
- 3. High load capacity  
The main output shaft adopts taper roller bearing to greater increase the radial and axial force.
- 4. Methods of flange and connector  
It can be installed on any motor in the world.
- 5. No grease leakage  
The use of grease with high viscosity which is not easy to separate effectively prevents the grease leakage.
- 6. Convenient maintenance  
No need to replace the grease in the product life period, and the installation is more convenient.

## Model Selection of Speed Reducers

### VRS Type

VRS090 - 10 - S1 - P1 / Motor

#### Reducer Model

VRS060, VRS075, VRS100, VRS140  
VRS180, VRS210, VRS240

#### Output Shaft Keyway

S1: Solid Output Shaft No Keyway  
S2: Standard (Keyway)  
S3: Output for holes

#### Motor Model

Motor Manufacturer & Model

#### Ratio

1-stage: 3, 4, 5, 6, 7, 8, 9, 10  
2-stage: 12, 15, 16, 20, 25, 28, 30, 35,  
40, 50, 70, 80, 100

#### Backlash Grade

P0: High precision backlash  
P1: Precision backlash  
P2: Standard backlash

The gearbox matching motor needs to be confirmed with following dimensions :

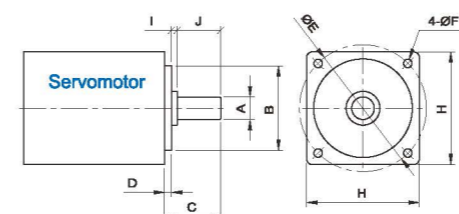

A	B	C	D	E	F	H	I	J

#### Naming Scheme:

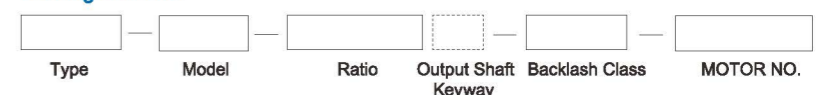

# VRS Reducer Specifications

Specs	Unit	Stage	Ratio	VRS060	VRS075	VRS100	VRS140	VRS180	VRS210	VRS240
Rated Output Torque / T2N	Nm	1	3	55	130	208	342	588	1140	1500
			4	50	140	290	542	1050	1700	2500
			5	60	160	330	650	1200	2000	2500
			6	55	150	310	600	1100	1900	2260
			7	50	140	300	550	1100	1800	2300
			8	45	120	260	500	1000	1600	2100
			9	40	100	230	450	900	1500	1800
		10	40	100	230	450	900	1500	1800	
		2	15	55	130	208	342	588	1140	2300
			16	55	130	208	342	588	1140	2300
			20	50	140	290	542	1050	1700	2500
			25	60	160	330	650	1200	2000	2500
			28	60	160	330	650	1200	2000	2500
			30	55	150	310	600	1100	1900	2300
35	50		140	300	550	1100	1800	2200		
40	45	120	260	500	1000	1600	2350			
50	60	160	330	650	1200	2000	2200			
70	50	140	300	550	1100	1800	2200			
100	40	100	230	450	900	1500	1800			
Max. Output Torque / T2N <sup>1</sup>	Nm	1,2	3~100	3Times of Nominal Output Torque						
Rated Input Speed / ΠIN	rpm	1,2	3~100	5000	4000	4000	3000	3000	2000	1000
Max. Input Speed / ΠIS	rpm	1,2	3~100	10000	8000	8000	6000	6000	4000	2500
Micro Backlash P0	arcmin	1	3~10	≤1	≤1	≤1	≤1	≤1	≤1	≤1
		2	12~100	≤3	≤3	≤3	≤3	≤3	≤3	≤3
Precision Backlash P1	arcmin	1	3~10	≤3	≤3	≤3	≤3	≤3	≤3	≤3
		2	15~100	≤5	≤5	≤5	≤5	≤5	≤5	≤5
Torsional Rigidity	Nm/arcmin	1,2	3~100	7	14	25	50	145	225	260
Max. Radial Force / F2R <sup>2</sup>	N	1,2	3~100	2750	4100	6400	9880	15000	20000	27500
Max. Axial Force / F2A1B <sup>2</sup>	N	1,2	3~100	2350	3200	5360	9690	14200	28000	30000
Service Life	hr	1,2	3~100	20000h						
Efficiency / η	%	1	3~10	≥96%						
		2	15~100	≥93%						
Weight	kg	1	3~10	1.8	3.8	7.2	16.8	32	49	65
		2	15~100	2.1	4.1	8.1	17.5	35	53	70
Operating Temperature	℃	1,2	3~100	(-15℃ ~ +90℃)						
Lubrication		1,2	3~100	(Synthetic Grease)						
Protection Class		1,2	3~100	IP65						
Mounting Position		1,2	3~100	(Any Direction)						
Noise Level (n1=3000rpm, No load)	dB(A)	1,2	3~100	≤62	≤62	≤65	≤68	≤68	≤70	≤70

## Reducer Rotary Inertia

Specs	Unit	Stage	Ratio	VRS060	VRS075	VRS100	VRS140	VRS180	VRS210	VRS240
Moment of Inertia	kg.cm <sup>2</sup>	1	3	0.16	0.61	3.25	9.21	28.98	69.61	82.16
			4	0.14	0.48	2.74	7.54	23.67	54.37	75.58
			5	0.13	0.47	2.71	7.42	23.29	53.27	75.29
			6	0.13	0.45	2.65	7.25	22.75	51.72	72.35
			7	0.13	0.45	2.62	7.14	22.48	50.97	69.13
			8	0.13	0.44	2.58	7.07	22.59	50.84	69.22
			9	0.13	0.44	2.57	7.04	22.53	50.63	66.23
		10	0.13	0.44	2.57	7.03	22.51	50.56	66.23	
		2	15~40	0.03	0.13	0.47	2.71	7.42	23.29	48.23
			50~100	0.03	0.13	0.44	2.57	7.03	22.51	45.58

1. Ratio (i=Nin/Nout)    2. When output speed is 100rpm, acting on the output shaft center position  
 3. \*Continuous operation, service life is 10000hrs

# MODEL: VRS

1-Stage

Ratio: 3, 4, 5, 6, 7, 8, 9, 10



## Dimensions:

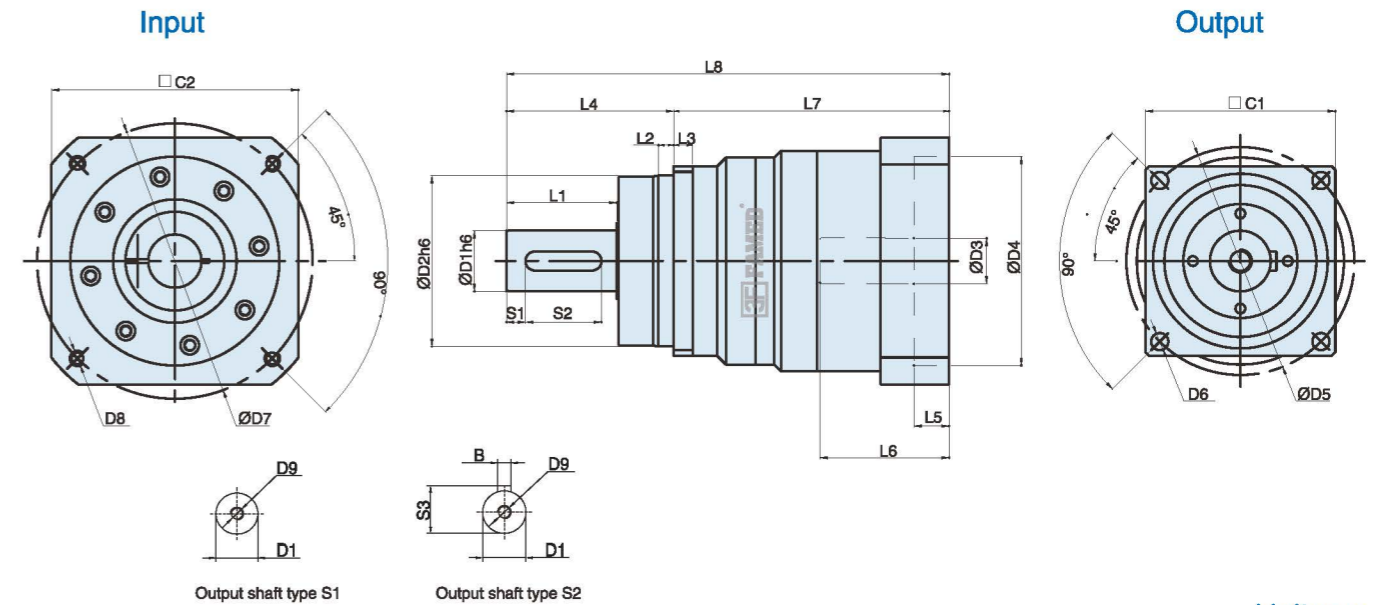

Unit:mm

Size	VRS060-L1	VRS075-L1	VRS100-L1	VRS140-L1	VRS180-L1	VRS210-L1	VRS240-L1
D1	16	22	32	40	55	75	85
D2	60	70	90	130	160	180	200
D3	8(8 ~ 19)	14(14 ~ 24)	19(19 ~ 35)	24(24 ~ 48)	38(38 ~ 48)	48(48 ~ 55)	60
D4	30(30 ~ 70)	50(50 ~ 110)	70(70 ~ 114.3)	110(110 ~ 114.3)	114.3(114.3 ~ 200)	200	220
D5	68	85	120	165	215	250	290
D6	4-Ø5.5	4-Ø6.6	4-Ø9	4-Ø11	4-Ø13.5	4-Ø17	4-Ø17
D7	46(45 ~ 90)	70(70 ~ 145)	90(90 ~ 200)	145(145 ~ 200)	200(200 ~ 235)	235	240
D8	M3 ~ M5	M4 ~ M8	M5 ~ M12	M8 ~ M12	M12	M12	M16
D9	M5	M8	M12	M16	M20	M20	M20
L1	28	36	58	82	82	105	130
L2	5	6	8	10	12	15	20
L3	6	7	10	12	15	17	20
L4	48	56	88	112	112	143	170
L5	7.5 ~ 9	10.5 ~ 16	12 ~ 36.5	8	10	10	12
L6	42 ~ 43.5	50.5 ~ 66	62 ~ 82	69 ~ 115	83 ~ 117	116	55
L7	94.5 ~ 96	117.5 ~ 133	139 ~ 153	170 ~ 216	210 ~ 244	257	295
L8	142.5 ~ 144	173.5 ~ 189	227 ~ 247	282 ~ 328	322 ~ 356	400	465
C1	60	75	100	140	182	215	240
C2	40(40 ~ 80)	60(60 ~ 130)	80(80 ~ 180)	130(130 ~ 180)	180(180 ~ 220)	220	250
S1	2	3	10	5	6	7	3
S2	22	28	40	70	70	90	105
S3	18	24.5	35	43	59	79.5	90
B	5	6	10	12	16	20	22

Note 1: Inside of ( ) is the optional range of sizes, outside of ( ) is the standard sizes.

Note 2: The reducer output shaft size and length can be customized for customers.

Note 3: The input size can be changed according to the servomotor or stepper motor of each brand.

# MODEL: VRS

2-Stage  
Ratio: 15, 16, 20, 25, 28, 30, 35, 40,  
50, 70, 100

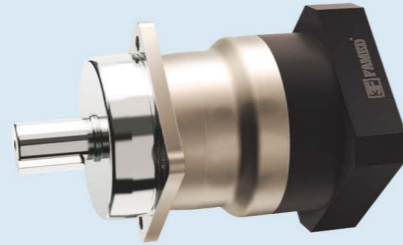

## Dimensions:

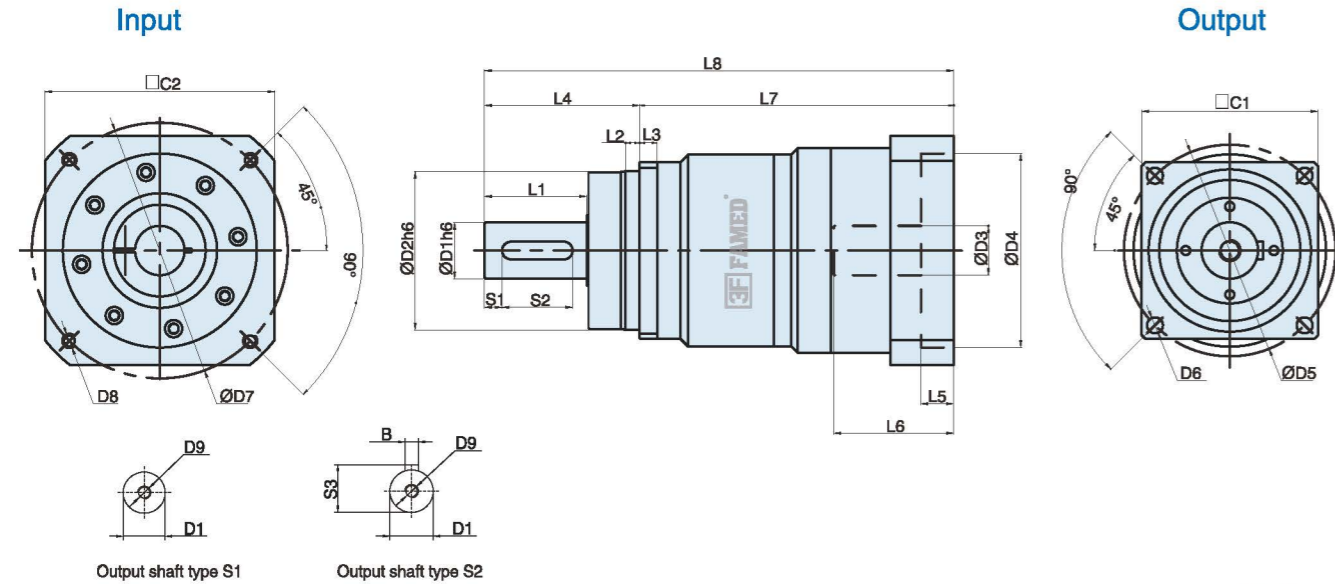

Unit:mm

Size	VRS060-L2	VRS075-L2	VRS100-L2	VRS140-L2	VRS180-L2	VRS210-L2	VRS240-L2
D1	16	22	32	40	55	75	85
D2	60	70	90	130	160	180	200
D3	8(8 ~ 14)	14(14 ~ 24)	19(19 ~ 28)	24(24 ~ 38)	38(24 ~ 42)	48(48 ~ 55)	48
D4	30(30 ~ 50)	50(50 ~ 110)	50(50 ~ 110)	110(110 ~ 114.3)	114.3(110 ~ 114.3)	200	220
D5	68	85	120	165	215	250	290
D6	4-Ø5.5	4-Ø6.6	4-Ø9	4-Ø11	4-Ø13.5	4-Ø17	4-Ø17
D7	46(45 ~ 70)	70(70 ~ 145)	70(70 ~ 145)	145(145 ~ 200)	200(145 ~ 200)	235	240
D8	M3 ~ M5	M4 ~ M8	M5 ~ M8	M8 ~ M12	M8 ~ M12	M12	M16
D9	M5	M8	M12	M16	M20	M20	M20
L1	28	36	58	82	82	105	130
L2	5	6	8	10	12	15	20
L3	6	7	10	12	15	17	20
L4	48	56	88	112	112	143	170
L5	8 ~ 9	10.5 ~ 16	12 ~ 18.5	6 ~ 8	6 ~ 10	10	12
L6	42.5 ~ 43.5	50.5 ~ 66	61 ~ 68	69 ~ 81	69 ~ 117	116	55
L7	116.5 ~ 117.5	143 ~ 158.5	172 ~ 178	210 ~ 222	236.5 ~ 293.5	257	346
L8	164.5 ~ 165.5	199 ~ 214.5	260 ~ 266	322 ~ 334	348.5 ~ 406.5	400	516
C1	60	75	100	140	182	215	240
C2	40(40 ~ 65)	60(60 ~ 130)	60(60 ~ 130)	130(130 ~ 180)	130(130 ~ 180)	220	250
S1	2	3	10	5	6	7	3
S2	22	28	40	70	70	90	105
S3	18	24.5	35	43	59	79.5	90
B	5	6	10	12	16	20	22

Note 1: Inside of ( ) is the optional range of sizes, outside of ( ) is the standard sizes.  
Note 2: The reducer output shaft size and length can be customized for customers.  
Note 3: The input size can be changed according to the servomotor or stepper motor of each brand.

# European High Precision High Torque Right Angle Planetary Gearbox

## EVS

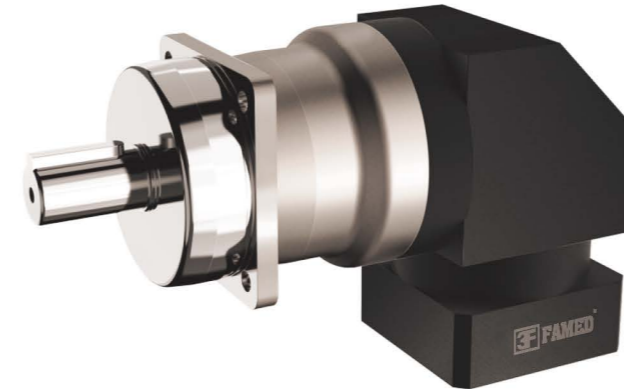

- 1. High precision  
The backlash is less than 3 arcmin and the positioning is accurate.
- 2. High rigidity & torque  
The use of integral ball bearings greatly improves the rigidity and torque.
- 3. High load capacity  
The main output shaft adopts taper roller bearing to greater increase the radial and axial force.
- 4. Methods of flange and connector  
It can be installed on any motor in the world.
- 5. No grease leakage  
The use of grease with high viscosity which is not easy to separate effectively prevents the grease leakage.
- 6. Convenient maintenance  
No need to replace the grease in the product life period, and the installation is more convenient.

## Model Selection of Speed Reducers

### EVS Type

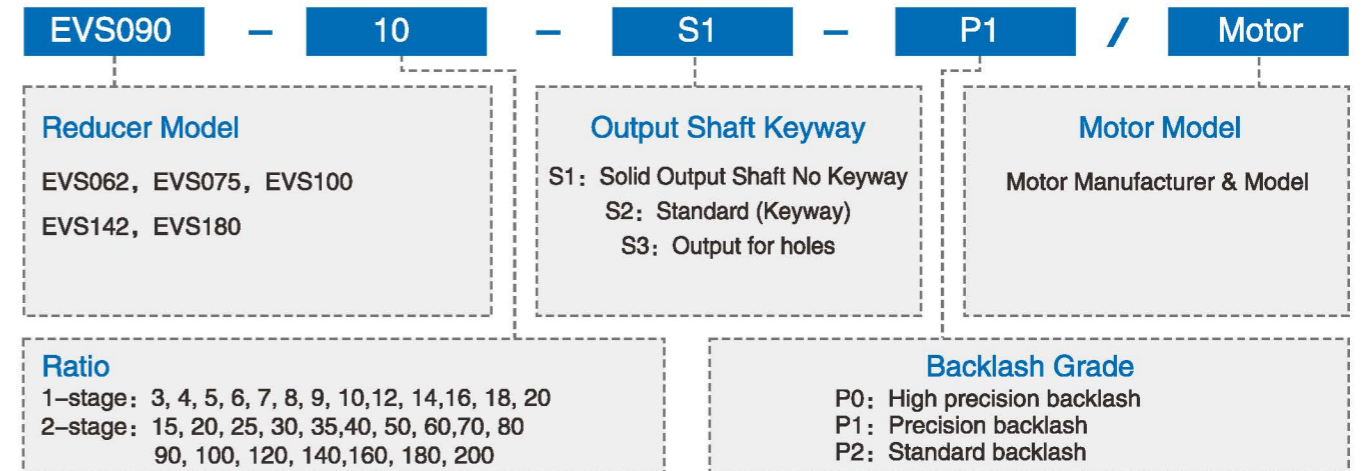

The gearbox matching motor needs to be confirmed with following dimensions :

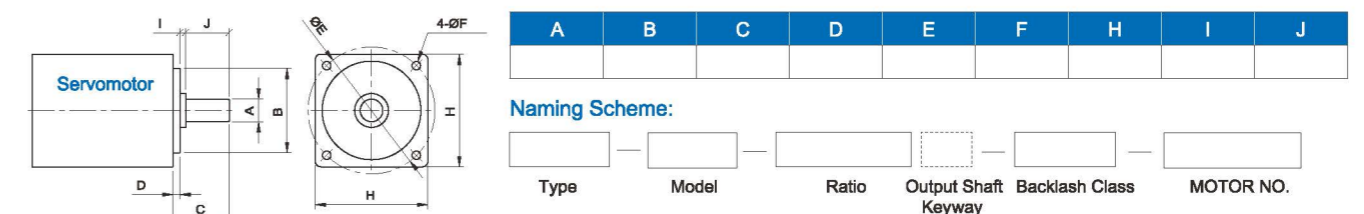

# EVS Reducer Specifications

Model No.	Code	Unit	Ratio	EVS062	EVS075	EVS100	EVS142	EVS180
Rated Output Torque (Nominal output torque)	T <sub>2N</sub>	Nm	3	59	165	216	625	1,206
			4	51	146	208	555	1,069
			5	48	155	333	618	1,189
			6	45	150	315	583	1,118
			7	45	142	309	573	1,108
			8	44	141	305	553	1,070
			9	44	140	293	551	1,060
			10	43	138	291	549	1,059
			12	45	150	315	583	1,118
			14	45	142	309	573	1,108
16	44	141	305	553	1,070			
18	44	140	293	551	1,060			
20	43	138	291	549	1,059			
Max. Acceleration Torque	T <sub>2B</sub>	Nm	3~20	1.8 Times of Rated Output Torque				
Max. Output Torque Emergency Stop Torque	T <sub>2NOT</sub>	Nm	3~20	3 Times of Rated Output Torque				
Rated Input Speed	n <sub>1N</sub>	rpm	3~20	3,000	3,000	3,000	3,000	3,000
Max. Input Speed	n <sub>1B</sub>	rpm	3~20	6,000	6,000	6,000	5,000	4,000
Backlash P <sub>s</sub>		arcmin	3~20	-	≤2	≤2	≤2	≤2
Backlash P <sub>0</sub>		arcmin	3~20	≤4	≤4	≤4	≤4	≤4
Backlash P <sub>1</sub>		arcmin	3~20	≤6	≤6	≤6	≤6	≤6
Backlash P <sub>2</sub>		arcmin	3~20	≤8	≤8	≤8	≤8	≤8
Torsional Rigidity		Nm/arcmin	3~20	8	15	27	60	150
Max. Radial Force	F <sub>2rB</sub>	N	3~20	2,240	4,150	8,760	12,750	17,860
Max. Axial Force	F <sub>2aB</sub>	N	3~20	1,920	3,780	7,500	10,840	15,180
Service Life	L <sub>H</sub>	hr	3~20	S5 Cycle Operation: >30,000 (S1 Continuous Operation: >15,000 hrs)				
Efficiency	η	%	3~20	≥95				
Operating Temperature		°C	3~20	-25° C ~ +90° C				
Lubrication			3~20	Synthetic Grease				
Protection Class			3~20	IP65				
Mounting Position			3~20	Any				
Noise Level		dB	3~20	≤68	≤70	≤72	≤74	≤76
Weight ±3%		Kg	3~20	2.7	7.5	10.9	25.6	57.9

## Reducer Rotary Inertia

Ratio	EVS062	EVS075	EVS100	EVS142	EVS180
3	0.30	2.11	6.42	18.36	57.65
4	0.28	2.02	5.61	18.02	56.17
5	0.26	2.01	5.42	17.21	55.05
6	0.24	2.00	5.33	16.50	53.44
7	0.24	1.97	5.09	15.85	51.10
8	0.24	1.94	5.06	14.94	49.03
9	0.24	1.94	5.04	14.61	48.08
10	0.24	1.94	5.02	14.02	41.33
12	0.22	1.94	4.98	13.86	41.12
14	0.22	1.94	4.95	13.53	40.50
16	0.21	1.92	4.91	13.03	40.11
18	0.21	1.91	4.87	12.57	39.73
20	0.20	1.88	4.75	12.11	38.65

# MODEL: EVS

1-Stage

Ratio: 3, 4, 5, 6, 7, 8, 9, 10, 12, 14, 16, 18, 20

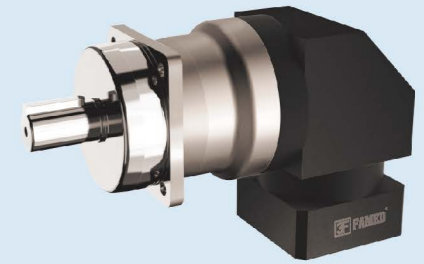

## Dimensions:

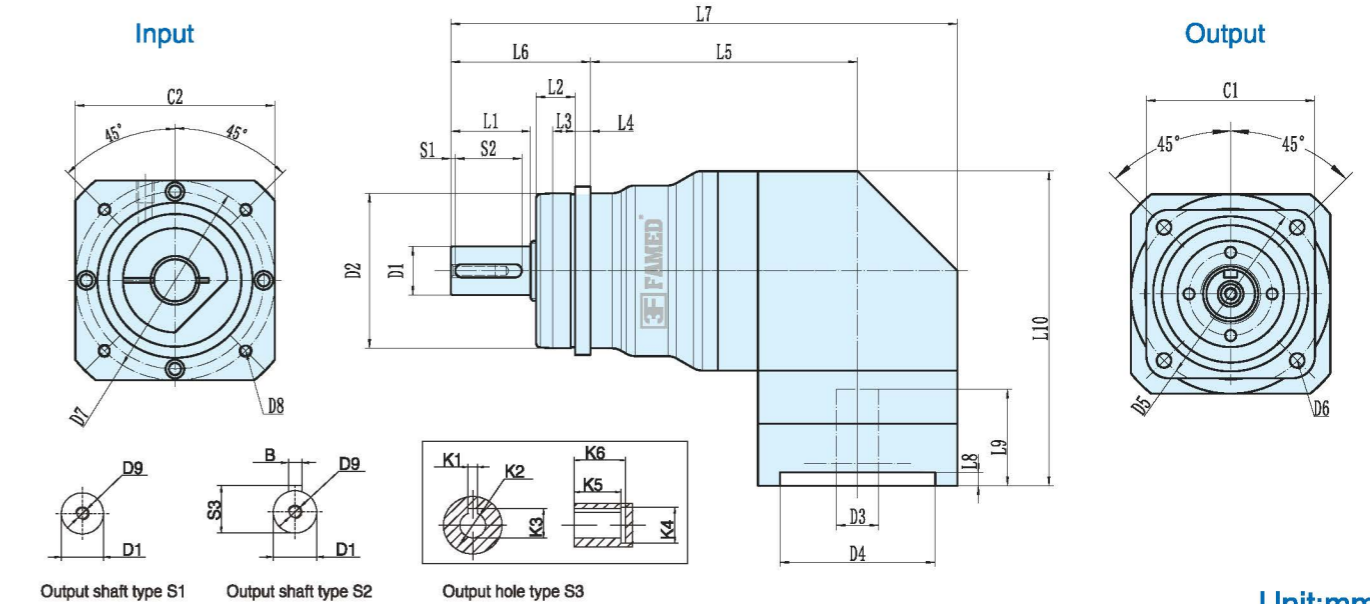

Unit:mm

Size	EVS062-L1	EVS075-L1	EVS100-L1	EVS142-L1	EVS180-L1
D1	φ 16	φ 22	φ 32	φ 40	φ 55
D2	φ 50	φ 70	φ 90	φ 130	φ 160
D3	φ 14 ( ≤19 )	φ 19 ( ≤24 )	φ 24 ( ≤35 )	φ 24 ( ≤42 )	φ 35 ( ≤42 )
D4	φ 50 ( ≤70 )	φ 70 ( ≤110 )	φ 110 ( ≤114.3 )	φ 110 ( ≤114.3 )	φ 114.3 ( ≤180 )
D5	φ 70	φ 85	φ 120	φ 165	φ 215
D6	4-φ 5.5	4-φ 6.6	4-φ 9	4-φ 11	4-φ 13
D7	φ 70 ( ≤130 )	φ 90 ( ≤145 )	φ 145 ( ≤200 )	φ 145 ( ≤200 )	φ 200 ( ≤300 )
D8	( 4-M4*10L )	( 4-M5*12.5L )	( 4-M8*20L )	( 4-M8*16L )	( 4-M12*30L )
D9	M5*12L	M6*15L	M12*25L	M16*36L	M20*42L
L1	28.5	36	56	82	82
L2	18	17.5	27	28	27
L3	10	10	15	10	15
L4	6	7	10	12	15
L5	87	120.5	143.5	163.5	117.5
L6	48	56	88	112	112
L7	171	228.5	299	347.5	394.5
L8	(4)	(6)	(14)	(19)	(10)
L9	(32.5)	(43.5)	(67.5)	(64.5)	(118)
L10	(98)	(142)	(185)	(220)	(276.5)
C1	□62	□76	□100	□140	□180
C2	( □60 )	( □90 )	( □130 )	( □130 )	( □180 )
S1	2	2	5	5	6
S2	25	30	40	68	70
S3	18	24.5	35.5	43	59
B	5	6	10	12	16
K1	4	6	8	10	14
K2	φ 11	φ 22	φ 28	φ 38	φ 50
K3	12.8	24.5	31.3	42	53.8
K4	φ 16	φ 32	φ 38	φ 48	φ 60
K5	15	20	27	35	43
K6	18	24	32	40	50

Note 1: Inside of ( ) is the optional range of sizes, outside of ( ) is the standard sizes.

Note 2: The reducer output shaft size and length can be customized for customers.

Note 3: The input size can be changed according to the servomotor or stepper motor of each brand.

# MODEL: EVS

2-Stage

Ratio: 15, 20, 25, 30, 35, 40, 50, 60, 70, 80, 90  
100, 120, 140, 160, 180, 200

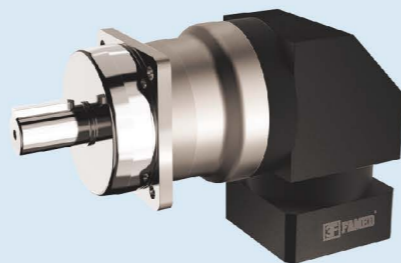

## Dimensions:

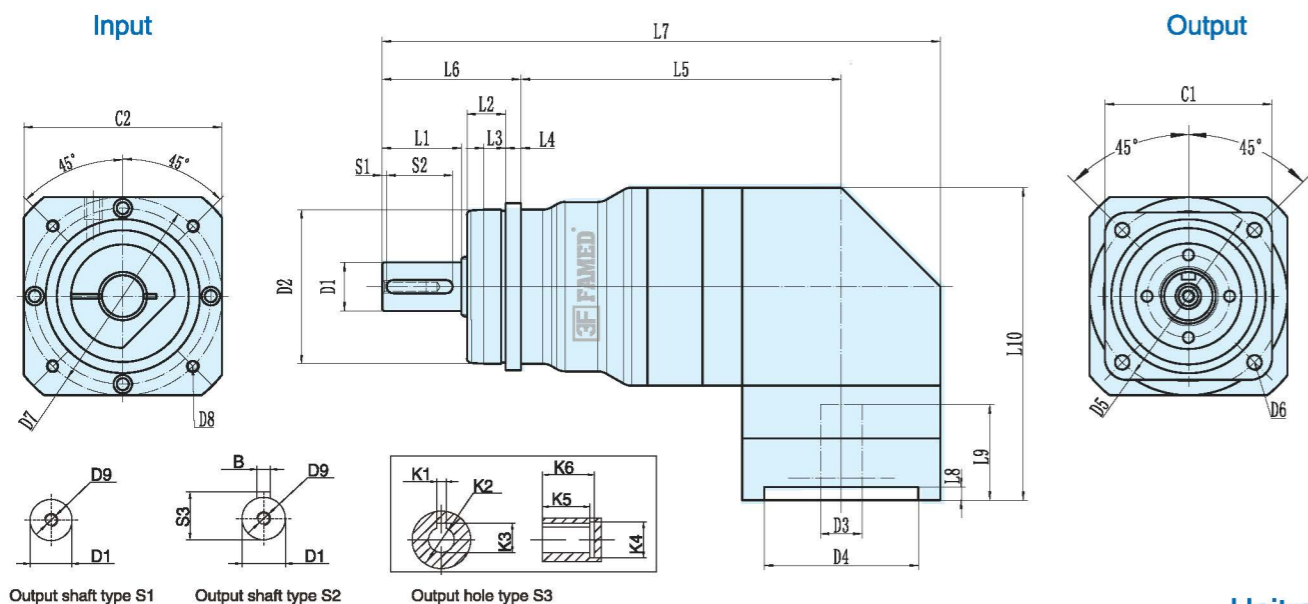

Unit:mm

Size	EVS062-L2	EVS075-L2	EVS100-L2	EVS142-L2	EVS180-L2
D1	φ 16	φ 22	φ 32	φ 40	φ 55
D2	φ 50	φ 70	φ 90	φ 130	φ 160
D3	φ 14 ( ≤19 )	φ 19 ( ≤24 )	φ 24 ( ≤35 )	φ 24 ( ≤35 )	φ 35 ( ≤55 )
D4	φ 50 ( ≤70 )	φ 70 ( ≤110 )	φ 110 ( ≤114.3 )	φ 110 ( ≤114.3 )	φ 114.3 ( ≤180 )
D5	φ 70	φ 85	φ 120	φ 165	φ 215
D6	4-φ 5.5	4-φ 6.6	4-φ 9	4-φ 11	4-φ 13
D7	φ 70 ( ≤130 )	φ 90 ( ≤145 )	φ 145 ( ≤200 )	φ 145 ( ≤200 )	φ 200 ( ≤300 )
D8	( 4-M4*10L )	( 4-M5*12.5L )	( 4-M8*20L )	( 4-M8*16L )	( 4-M12*30L )
D9	M5*12L	M6*15L	M12*25L	M16*36L	M20*42L
L1	28.5	36	56	82	82
L2	18	17.5	27	28	27
L3	10	10	15	10	15
L4	6	7	10	12	15
L5	103.5	148.5	174.5	194.5	217.5
L6	48	56	88	112	112
L7	187.5	256.5	330	378.5	434.5
L8	( 4 )	( 6 )	( 14 )	( 6 )	( 10 )
L9	( 32.5 )	( 43.5 )	( 67.5 )	( 55.5 )	( 118 )
L10	( 98 )	( 142 )	( 185 )	( 196 )	( 276.5 )
C1	□ 62	□ 76	□ 100	□ 140	□ 180
C2	( □ 60 )	( □ 90 )	( □ 130 )	( □ 130 )	( □ 180 )
S1		2	5	5	6
S2	25	30	40	68	70
S3	18	24.5	35.5	43	59
B	5	6	10	12	16
K1	4	6	8	10	14
K2	φ 11	φ 22	φ 28	φ 38	φ 50
K3	12.8	24.5	31.3	42	53.8
K4	φ 16	φ 32	φ 38	φ 48	φ 60
K5	15	20	27	35	43
K6	18	24	32	40	50

Note 1: Inside of ( ) is the optional range of sizes, outside of ( ) is the standard sizes.

Note 2: The reducer output shaft size and length can be customized for customers.

Note 3: The input size can be changed according to the servomotor or stepper motor of each brand.

# High Precision High Torque Planetary Gearbox

## PAB



- The integral structure of the planetary wall frame and the output shaft ensures the maximum torsion rigidity and stability
- The surface of the gear box is treated with electroless Nickel, and the plate is treated with blue anode to improve the tolerance and corrosion resistance of the environment.
- Lowest backlash
- High efficiency 95%
- Life time lubrication

## Model Selection of Speed Reducers

### PAB Type

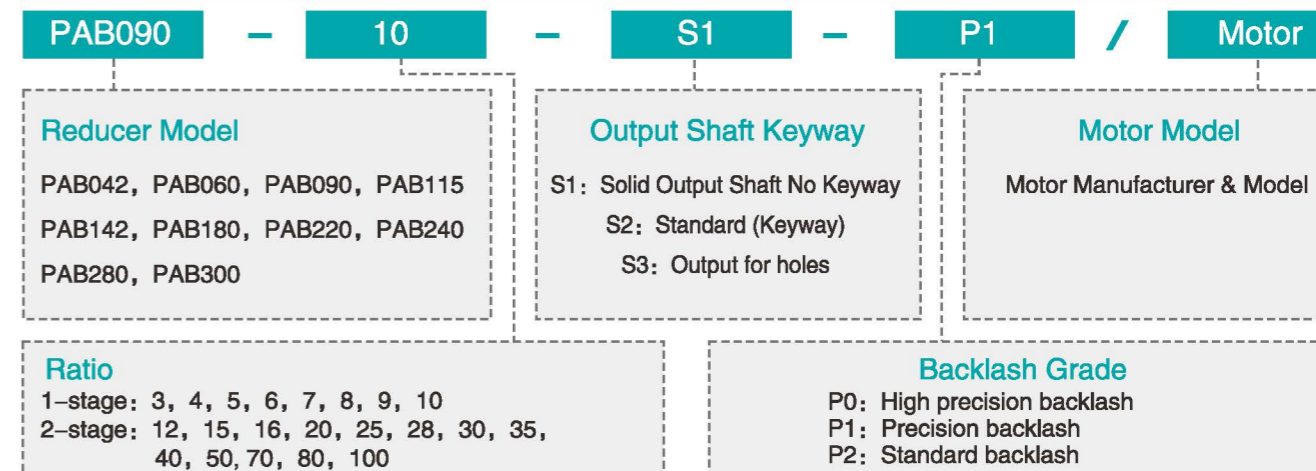

The gearbox matching motor needs to be confirmed with following dimensions :

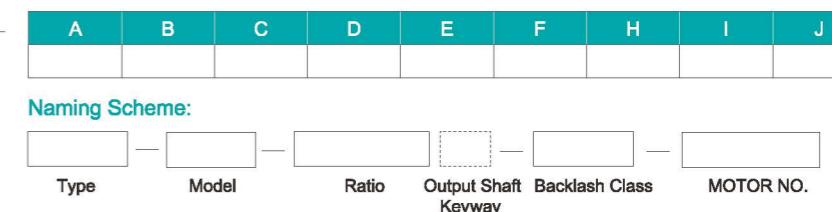
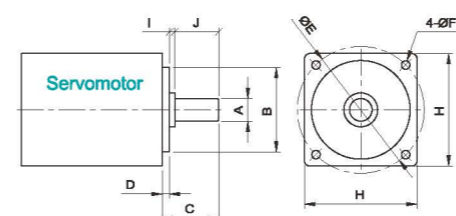

# PAB Reducer Specifications

Specs	Unit	Stage	Ratio	PAB042	PAB060	PAB090	PAB115	PAB142	PAB180	PAB220	PAB242	PAB285	PAB330	
Rated Output Torque / T <sub>2NOT</sub>	Nm	1	3	19	55	130	230	450	950	1220	1900	4230	8200	
			4	20	55	160	290	580	1050	2000	3200	5800	10190	
			5	21	58	159	330	650	1250	2100	2500	4400	7180	
			6	16	48	120	310	600	1100	1350	—	—	—	
			7	19	50	148	300	550	1100	1800	1830	3520	9800	
			8	13	45	130	260	500	880	1600	1360	2595	4080	
			9	12	40	100	220	350	588	1140	—	—	—	
			10	15	40	100	208	342	520	1140	1150	1820	5000	
			2	12	18	52	130	300	342	588	1220	1820	4230	8200
				15	18	53	130	280	450	950	1650	2420	5620	8200
		16		20	53	158	320	580	1200	2050	3390	6400	10800	
		20		20	60	160	320	650	1200	2050	3390	6400	10800	
		25		20	60	160	320	650	1200	2100	2650	4710	7550	
		28		20	60	150	300	550	1100	1850	2650	4710	7550	
		30		18	50	130	230	450	950	1600	1820	4230	7000	
		35		20	60	160	390	650	1200	2100	2420	5620	9800	
		40	18	50	140	290	542	1100	2000	2650	4710	7550		
		50	22	60	160	290	650	1200	2100	2650	4710	7550		
70	19	50	140	280	600	1000	1800	1900	3520	5000				
80	17	43	120	230	500	880	1600	—	—	—				
100	14	40	100	260	342	520	1140	1200	1820	2500				
Max.Output Torque / T <sub>2NOT</sub> <sup>1</sup>	Nm	1,2	3~100	3Times of Nominal Output Torque										
Rated Input Speed / Π <sub>IN</sub>	rpm	1,2	3~100	4000	4000	4000	3500	3000	2000	2000	1000	1000	1000	
Max.Input Speed / Π <sub>IN</sub>	rpm	1,2	3~100	6000	6000	6000	5500	4500	4500	4000	1500	1500	1500	
Micro Backlash P0	arcmin	1	3~10	≤1	≤1	≤1	≤1	≤1	≤1	≤1	—	—	—	
		2	12~100	≤3	≤3	≤3	≤3	≤3	≤3	≤3	—	—	—	
Precision Backlash P1	arcmin	1	3~10	≤3	≤3	≤3	≤3	≤3	≤3	≤3	—	—	—	
		2	12~100	≤5	≤5	≤5	≤5	≤5	≤5	≤5	—	—	—	
Standard Backlash P2	arcmin	1	3~10	≤5	≤5	≤5	≤5	≤5	≤5	≤5	≤8	≤8	≤8	
		2	12~100	≤7	≤7	≤7	≤7	≤7	≤7	≤7	≤10	≤10	≤10	
Torsional Rigidity	Nm/arcmin	1,2	3~100	3	7	12	25	50	140	210				
Max.Radial Force / F <sub>2R</sub> <sup>2</sup>	N	1,2	3~100	780	1300	3200	6750	9400	14500	50000	55000	59000	62000	
Max.Axial Force / F <sub>2A</sub> <sup>2</sup>	N	1,2	3~100	330	700	1580	3300	4700	7200	28000	29000	30000	33000	
Service Life	hr	1,2	3~100	21000h										
Efficiency / η	%	1	3~10	≥97%										
		2	12~100	≥94%										
Weight	kg	1	3~10	0.5	1.3	3.7	7.8	15	29	52	71	113	245	
		2	12~100	0.8	1.48	4.1	9.6	18.9	33	66	75	136	290	
Operating Temperature	°C	1,2	3~100	(-15°C ~ +90°C)										
Lubrication		1,2	3~100	(Synthetic Grease)										
Protection Class		1,2	3~100	IP65										
Mounting Position		1,2	3~100	(Any Direction)										
Noise Level (n1=3000rpm, No load)	dB(A)	1,2	3~100	≤63	≤63	≤63	≤65	≤65	≤70	≤70	≤75	≤75	≤75	

## Reducer Rotary Inertia

Specs	Unit	Stage	Ratio	PAB042	PAB060	PAB090	PAB115	PAB142	PAB180	PAB220	PAB242	PAB285	PAB330	
Moment of Inertia	kg.cm <sup>2</sup>	1	3	0.03	0.16	0.61	3.25	9.21	28.98	69.61	70.21	73.29	75.23	
			4	0.03	0.14	0.48	2.74	7.54	23.67	54.37	58.21	70.27	73.37	
			5	0.03	0.13	0.47	2.71	7.42	23.29	53.27	59.27	70.61	73.29	
			6	0.03	0.13	0.45	2.65	7.25	22.75	51.72	53.37	55.72	58.75	
			7	0.03	0.13	0.45	2.62	7.14	22.48	50.97	51.23	53.97	56.61	
			8	0.03	0.13	0.44	2.58	7.07	22.59	50.84	51.72	53.84	56.24	
			9	0.03	0.13	0.44	2.57	7.04	22.53	50.63	55.27	58.63	60.54	
			10	0.03	0.13	0.44	2.57	7.03	22.51	50.56	55.27	58.56	60.72	
			2	12~40	0.03	0.03	0.13	0.47	2.71	7.42	23.29	29.20	31.29	24.29
				50~100	0.03	0.03	0.13	0.44	2.57	7.03	22.51	28.20	30.51	35.51

1. The Max. acceleration torque T<sub>2B</sub>=60% of T<sub>2NOT</sub> 2. When output speed is 100rpm, inertia acts on the output shaft center position.  
3. 3-stage big ratios are not in the above table. There is shaft lengthening and enlarging design. Please tell sales person if you need it.

# MODEL: PAB

1-Stage

Ratio: 3, 4, 5, 6, 7, 8, 9, 10



## Dimensions:

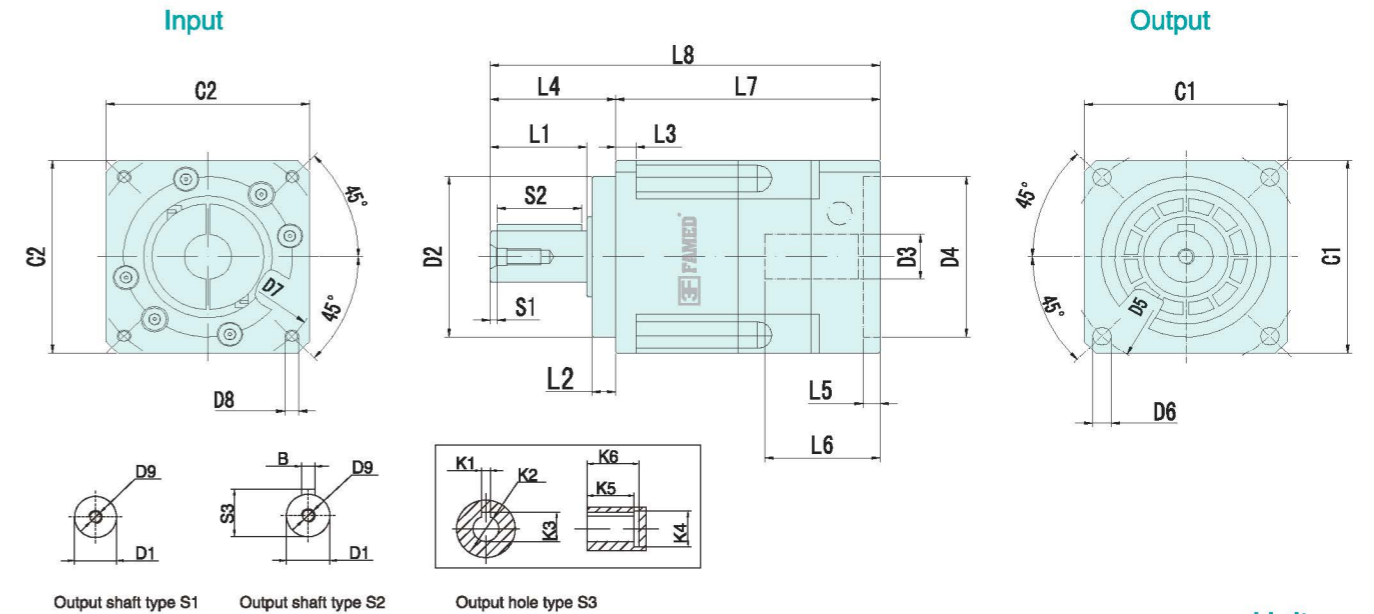

Output shaft type S1    Output shaft type S2    Output hole type S3

Unit:mm

Size	PAB042-L1	PAB060-L1	PAB090-L1	PAB115-L1	PAB142-L1	PAB180-L1	PAB220-L1	PAB242-L1	PAB285-L1	PAB330-L1
D1	φ 13	φ 16	φ 22	φ 32	φ 40	φ 55	φ 75	φ 55	φ 70	φ 80
D2	φ 35	φ 50	φ 80	φ 110	φ 130	φ 160	φ 180	φ 220	φ 250	φ 290
D3	φ 8(≤11)	φ 14(≤14)	φ 19(≤24)	φ 24(≤32)	φ 35(≤42)	φ 38(≤50)	φ 55(≤55)	φ 42	φ 55	φ 60
D4	φ 30(30-50)	φ 50(30-70)	φ 70(50-110)	φ 110(50-130)	φ 114.3(95-180)	φ 180(95-180)	φ 215(180-255)	φ 200(114.3-200)	φ 200	φ 230
D5	φ 50	φ 70	φ 100	φ 130	φ 165	φ 215	φ 250	φ 265	φ 315	φ 370
D6	4-φ 3.4	4-φ 5.5	4-φ 6.6	4-φ 9	4-φ 11	4-φ 13	4-φ 17	4-φ 18	4-φ 18	4-φ 22
D7	φ 46(22-70)	φ 70(45-90)	φ 90(70-145)	φ 145(70-145)	φ 200(90-215)	φ 200(90-300)	φ 235(200-300)	φ 200(200-235)	φ 235	φ 265
D8	(4-M3X8L)	(4-M5X10L)	(4-M6X12L)	(4-M8X25L)	(4-M12X30L)	(4-M12X30L)	(4-M12X30L)	4-M12	4-M12	4-M12
D9	M4X0.7P	M5X0.8P	M8X1.25P	M12X1.75P	M16X2.0P	M20X2.5P	M20X2.5P	M20X40	M16X35	M16X35
L1	19	28.5	36.5	51	79	82	105	105	110	120
L2	5.5	7	10	12	15	20	30	20	20	25
L3	4	6	8	10	12	15	20	22	25	30
L4	26	37	48	65	97	105	138	130	135	150
L5	( 4 )	( 5 )	( 7 )	( 11 )	( 7 )	( 7 )	( 12.5 )	15	7	10
L6	30	34	45	65	67.5	85	105	118	115	145
L7	( 65.5 )	( 78 )	( 99 )	( 135 )	( 150 )	( 182 )	( 226 )	262	282	391
L8	( 91.5 )	( 115 )	( 147 )	( 200 )	( 247 )	( 287 )	( 365 )	392(≤392)	417	541
C1	□42	□60	□90	□115	□142	□180	□220	□242	□285	□330
C2	(□42)	(□60)	(□90)	(□130)	(□142)	(□180)	(□220)	220	285	150
S1	2	2	3	5	5	5	7	5	5	5
S2	16	25	32	40	65	70	90	90	100	110
S3	15	18	24.5	35	43	59	79	74.5	74.5	85
B	5	5	6	10	12	16	20	20	20	22
K1	-	4	6	8	10	14	16	-	-	-
K2	-	φ 11	φ 22	φ 28	φ 38	φ 50	φ 60	-	-	-
K3	-	12.7	25	31.3	42	53.8	64.4	-	-	-
K4	-	φ 16	φ 32	φ 38	φ 48	φ 60	φ 72	-	-	-
K5	-	15	20	27	35	43	60	-	-	-
K6	-	18	24	32	40	50	65	-	-	-

Note 1: Inside of ( ) is the optional range of sizes, outside of ( ) is the standard sizes.

Note 2: The reducer output shaft size and length can be customized for customers.

Note 3: The input size can be changed according to the servomotor or stepper motor of each brand.

# MODEL: PAB

2-Stage

Ratio: 12, 15, 16, 20, 25, 28, 30, 35, 40, 50  
70, 80, 100



## Dimensions:

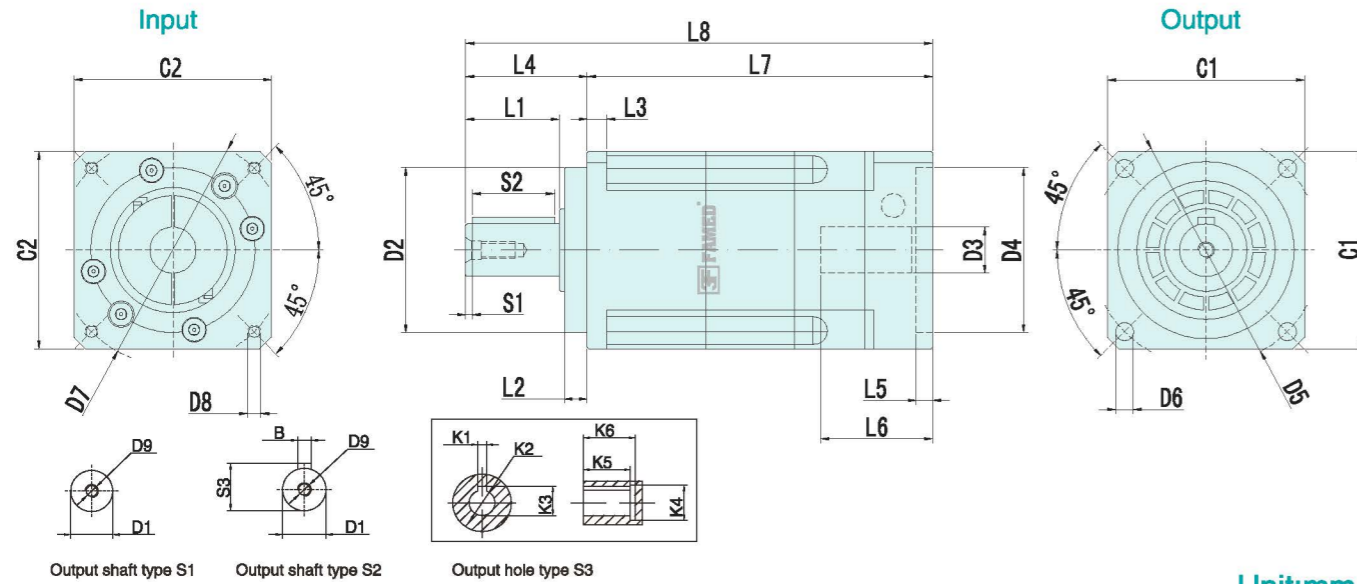

Unit:mm

Size	PAB042-L2	PAB060-L2	PAB090-L2	PAB115-L2	PAB142-L2	PAB180-L2	PAB220-L2	PAB242-L2	PAB285-L2	PAB330-L2
D1	φ 13	φ 16	φ 22	φ 32	φ 40	φ 55	φ 75	φ 55	φ 70	φ 80
D2	φ 35	φ 50	φ 80	φ 110	φ 130	φ 160	φ 180	φ 220	φ 250	φ 290
D3	φ 8(≤11)	φ 14(≤14)	φ 19	φ 24(≤32)	φ 35(≤42)	φ 38(≤50)	φ 55(≤55)	φ 38(≤42)	φ 42	φ 42
D4	φ 30(30-50)	φ 50(30-70)	φ 70	φ 110(50-130)	φ 114.3(95-180)	φ 180(95-180)	φ 215(180-255)	φ 200(114.3-200)	φ 200(114.3-200)	φ 200(114.3-200)
D5	φ 50	φ 70	φ 100	φ 130	φ 165	φ 215	φ 250	φ 265	φ 315	φ 370
D6	4-φ 3.4	4-φ 5.5	4-φ 6.6	4-φ 9	4-φ 11	4-φ 13	4-φ 17	4-φ 18	4-φ 18	4-φ 22
D7	φ 46(22-70)	φ 70(45-90)	φ 90	φ 145(70-145)	φ 200(90-215)	φ 200(90-300)	φ 235(200-300)	φ 200(200-235)	φ 200(200-235)	φ 200(200-235)
D8	(4-M3X8L)	(4-M5X10L)	(4-M6X12L)	(4-M8X25L)	(4-M12X30L)	(4-M12X30L)	(4-M12X30L)	4-M12	4-M12	4-M12
D9	M4X0.7P	M5X0.8P	M8X1.25P	M12X1.75P	M16X2.0P	M20X2.5P	M20X2.5P	M20X4	M16X35	M16X35
L1	19	28.5	36.5	51	79	82	105	105	110	120
L2	5.5	7	10	12	15	20	30	20	20	25
L3	4	6	8	10	12	15	20	22	25	30
L4	26	37	48	65	97	105	138	130	135	150
L5	( 4 )	( 5 )	( 7 )	( 11 )	( 7 )	( 7 )	( 12.5 )	7	15	15
L6	25	34	45	65	67.5	85	105	120(≤120)	118	118
L7	( 93 )	( 117 )	( 144 )	( 161 )	( 196 )	( 232 )	( 277 )	325	402.5	459
L8	( 114 )	( 154 )	( 192 )	( 226 )	( 293 )	( 337 )	( 415 )	455(≤455)	537.5	609
C1	□42	□60	□90	□115	□142	□180	□220	□242	□285	□330
C2	(□42)	(□60)	(□90)	(□130)	(□142)	(□180)	(□220)	180(≤180)	220	220
S1	2	2	3	5	5	5	7	5	5	5
S2	16	25	32	40	65	70	90	90	100	110
S3	15	18	24.5	35	43	59	79	74.5	74.5	85
B	5	5	6	10	12	16	20	20	20	22
K1	-	4	6	8	10	14	16	-	-	-
K2	-	φ 11	φ 22	φ 28	φ 38	φ 50	φ 60	-	-	-
K3	-	12.7	25	31.3	42	53.8	64.4	-	-	-
K4	-	φ 16	φ 32	φ 38	φ 48	φ 60	φ 72	-	-	-
K5	-	15	20	27	35	43	60	-	-	-
K6	-	18	24	32	40	50	65	-	-	-

Note 1: Inside of ( ) is the optional range of sizes, outside of ( ) is the standard sizes.  
Note 2: The reducer output shaft size and length can be customized for customers.  
Note 3: The input size can be changed according to the servomotor or stepper motor of each brand.

# High Precision High Torque Right Angle Planetary Gearbox

## PAR



- 1. Space-saving  
The straight cross reducer uses spiral bevel gear. The installation of the motor can achieve 90 degree bending and save the installation space.
- 2. High rigidity & torque  
The use of integral needle roller bearings greatly improves the rigidity and torque.
- 3. Connector and shaft sleeve mode  
It can be installed on any motor in the world.
- 4. No grease leakage  
The use of grease with high viscosity which is not easy to separate effectively prevents the grease leakage.
- 5. Convenient maintenance  
No need to replace the grease in the product life period, and the installation is more convenient.

## Model Selection of Speed Reducers

### PAR Type

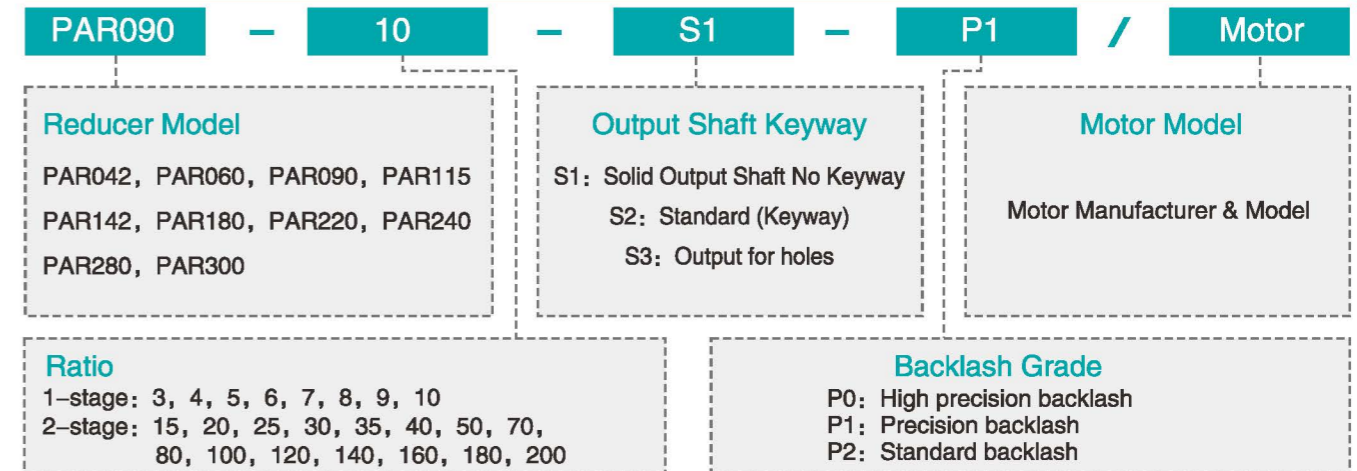

The gearbox matching motor needs to be confirmed with following dimensions :

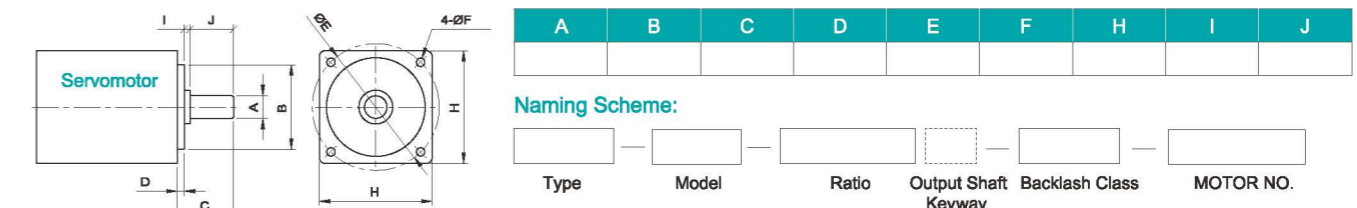

# PAR Reducer Specifications

Specs	Unit	Stage	Ratio	PAR042	PAR060	PAR090	PAR115	PAR142	PAR180	PAR220
Rated Output Torque / T2N	Nm	1	3	19	55	130	230	450	950	1220
			4	20	55	160	290	580	1050	2000
			5	21	58	159	330	650	1250	2100
			6	16	48	120	310	600	1100	1350
			7	19	50	148	300	550	1100	1800
			8	13	45	130	260	500	880	1600
			9	12	40	100	220	350	588	1140
			10	15	40	100	208	342	520	1140
			14	18	50	130	300	550	1100	1800
			20	15	40	130	208	342	520	1140
		2	15	20	55	130	320	650	1200	2050
			20	20	60	160	320	650	1200	2100
			25	20	60	150	300	550	1100	1850
			30	18	50	130	230	450	950	1600
			35	20	60	160	390	650	1200	2100
			40	18	50	140	290	542	1100	2000
			50	18	60	160	290	650	1200	2100
			70	16	50	140	280	600	1000	1800
			80	10	43	120	230	500	880	1600
			100	10	40	100	260	342	520	1140
120	—	—	130	310	500	1100	1900			
140	—	—	130	300	530	1100	1800			
160	—	—	120	260	520	1000	1600			
180	—	—	100	230	450	900	1500			
200	—	—	100	230	450	900	1500			
Max.Output Torque / T2NOT <sup>1</sup>	Nm	1,2	3~200	3Times of Nominal Output Torque						
Rated Input Speed / Π1N	rpm	1,2	3~200	3000	3000	3000	3000	2500	2000	2000
Max.Input Speed / Π1a	rpm	1,2	3~200	6000	6000	6000	5500	4500	4500	4000
Precision Backlash P0	arcmin	1	3~20	≤1	≤1	≤1	≤1	≤1	≤1	≤1
Precision Backlash P1	arcmin	1	3~20	≤3	≤3	≤3	≤3	≤3	≤3	≤3
		2	15~200	≤5	≤5	≤5	≤5	≤5	≤5	≤5
Standard Backlash P2	arcmin	1	3~20	≤5	≤5	≤5	≤5	≤5	≤5	≤5
		2	15~200	≤7	≤7	≤7	≤7	≤7	≤7	≤7
Torsional Rigidity	Nm/arcmin	1,2	3~200	3	6	14	25	56	140	220
Max.Radial Force / F2a <sup>2</sup>	N	1,2	3~200	780	1300	3200	6750	9400	14500	50000
Max.Axial Force / F2a1a <sup>2</sup>	N	1,2	3~200	330	700	1580	3300	4700	7200	28000
Service Life	hr	1,2	3~200	21000 h						
Efficiency / η	%	1	3~20	≥93%						
		2	25~200	≥90%						
Weight	kg	1	3~20	0.9	1.5	6.4	13	24.5	51	83
		2	25~200	1.2	2.1	7.8	14.2	27.5	54	95
Operating Temperature	℃	1,2	3~200	(-15℃ ~ +90℃)						
Lubrication		1,2	3~200	(Synthetic Grease)						
Protection Class		1,2	3~200	IP65						
Mounting Position		1,2	3~200	(Any Direction)						
Noise Level (n1=3000rpm, No load)	dB(A)	1,2	3~200	≤65	≤65	≤68	≤68	≤70	≤72	≤74

## Reducer Rotary Inertia

Specs	Unit	Stage	Ratio	PAR042	PAR060	PAR090	PAR115	PAR142	PAR180	PAR220
Moment of Inertia	kg.cm <sup>2</sup>	1	3~10	0.09	0.35	2.25	6.84	23.4	68.9	135.4
			14~20	0.03	0.07	1.87	6.25	21.8	65.6	119.8
		2	15~100	0.09	0.09	0.35	2.25	6.84	23.4	68.9
120~200	—		—	0.31	1.87	6.25	21.8	65.6		

1. The Max. acceleration torque T2B=60% of T2NOT 2. When output speed is 100rpm, inertia acts on the output shaft center position.  
3. 3-stage big ratios are not in the above table. There is shaft lengthening and enlarging design. Please tell sales person if you need it.

# MODEL: PAR

1-Stage

Ratio: 3, 4, 5, 6, 7, 8, 9, 10, 14, 16, 20

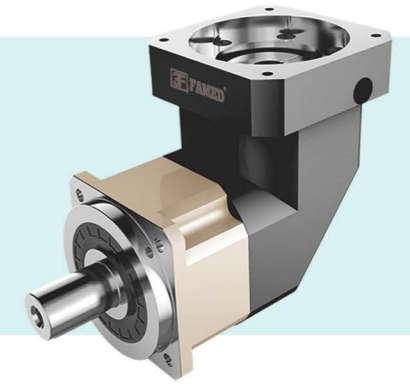

## Dimensions:

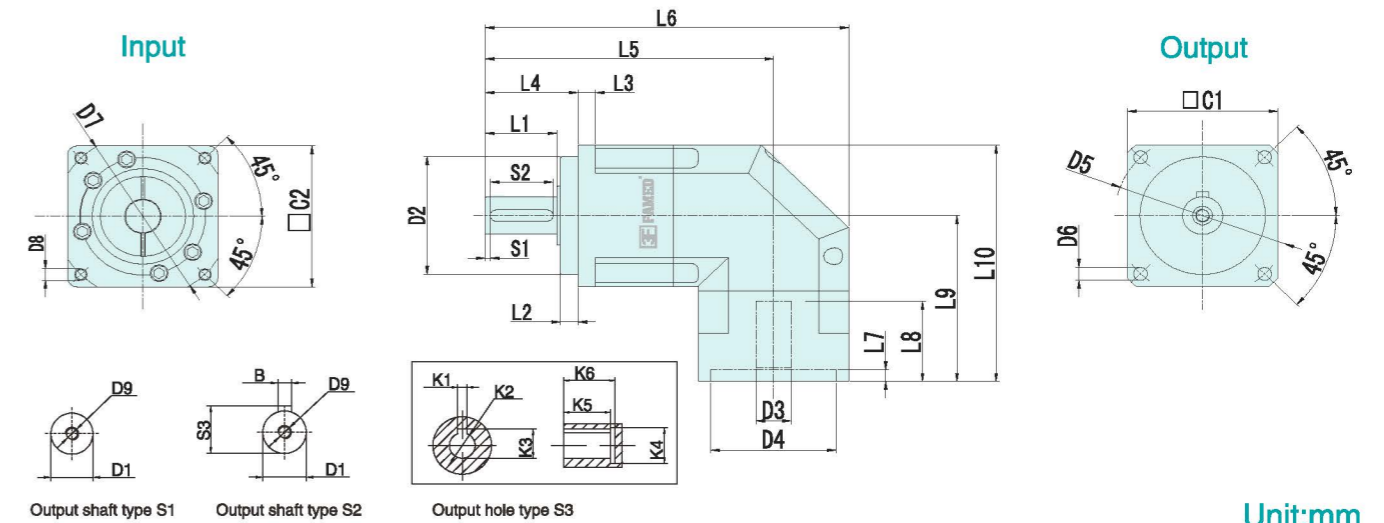

Unit:mm

Size	PAR042-L1	PAR060-L1	PAR090-L1	PAR115-L1	PAR142-L1	PAR180-L1	PAR220-L1
D1	φ 13	φ 16	φ 22	φ 32	φ 40	φ 55	φ 75
D2	φ 35	φ 50	φ 80	φ 110	φ 130	φ 160	φ 180
D3	φ 8(≤11)	φ 14(≤14)	φ 19(≤24)	φ 24(≤32)	φ 35(≤42)	φ 38(≤50)	φ 55(≤55)
D4	φ 30(30~50)	φ 50(30~70)	φ 70(50~110)	φ 110(50~130)	φ 114.3(95~180)	φ 180(95~180)	φ 215(180~255)
D5	φ 50	φ 70	φ 100	φ 130	φ 165	φ 215	φ 250
D6	4-φ 3.4	4-φ 5.5	4-φ 6.6	4-φ 9	4-φ 11	4-φ 13	4-φ 17
D7	φ 46(22~70)	φ 70(45~90)	φ 90(70~145)	φ 145(70~145)	φ 200(90~215)	φ 200(90~300)	φ 235(200~300)
D8	(4-M3X8L)	(4-M5X10L)	(4-M6X12L)	(4-M8X25L)	(4-M12X30L)	(4-M12X30L)	(4-M12X30L)
D9	M4X0.7P	M5X0.8P	M8X1.25P	M12X1.75P	M16X2.0P	M20X2.5P	M20X2.5P
L1	19	28.5	36.5	51	79	82	105
L2	5.5	7	10	12	15	20	30
L3	4	6	8	10	12	15	20
L4	26	37	48	65	97	105	138
L5	96	117	175	227	255	289	346
L6	(122)	(154)	(223)	(292)	(352)	(394)	(484)
L7	(3.5)	(5)	(5)	(11)	(14)	(15)	(7)
L8	(30)	(34)	(44)	(60)	(81)	(85)	(85)
L9	(69.5)	(81.5)	(107.5)	(134)	(165)	(213.5)	(268.5)
L10	(95.5)	(110.5)	(158)	(199)	(230)	(303.5)	(378.5)
C1	□42	□60	□90	□115	□142	□180	□220
C2	(□42)	(□60)	(□90)	(□130)	(□142)	(□180)	(□220)
S1	2	2	2	5	5	5	7
S2	16	25	32	40	65	70	90
S3	15	18	24.5	35	43	59	79
B	5	5	6	10	12	16	20
K1	—	4	6	8	10	14	16
K2	—	φ 11	φ 22	φ 28	φ 38	φ 50	φ 60
K3	—	12.7	25	31.3	42	53.8	64.4
K4	—	φ 16	φ 32	φ 38	φ 48	φ 60	φ 72
K5	—	15	20	27	35	43	60
K6	—	18	24	32	40	50	65

Note 1: Inside of ( ) is the optional range of sizes, outside of ( ) is the standard sizes.

Note 2: The reducer output shaft size and length can be customized for customers.

Note 3: The input size can be changed according to the servomotor or stepper motor of each brand.

# MODEL: PAR

2-Stage

Ratio: 15, 20, 25, 30, 35, 40, 50, 70, 80, 100, 120, 140, 160, 180, 200

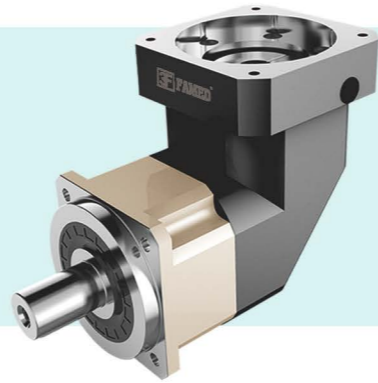

## Dimensions:

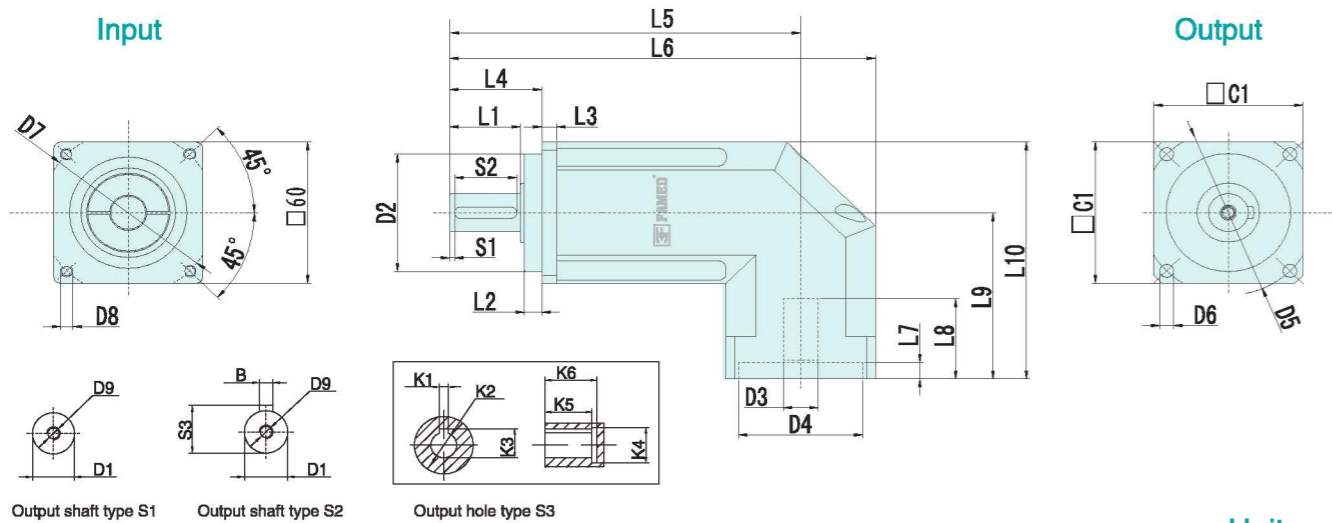

Unit:mm

Size	PAR042-L2	PAR060-L2	PAR090-L2	PAR115-L2	PAR142-L2	PAR180-L2	PAR220-L2
D1	φ 13	φ 16	φ 22	φ 32	φ 40	φ 55	φ 75
D2	φ 35	φ 50	φ 80	φ 110	φ 130	φ 160	φ 180
D3	φ 8(≤11)	φ 14(≤14)	φ 14	φ 24(≤32)	φ 35(≤42)	φ 38(≤50)	φ 55(≤55)
D4	φ 30(30-50)	φ 50(30-70)	φ 50	φ 110(50-130)	φ 114.3(95-180)	φ 180(95-180)	φ 215(180-255)
D5	φ 50	φ 70	φ 100	φ 130	φ 165	φ 215	φ 250
D6	4-φ 3.4	4-φ 5.5	4-φ 6.6	4-φ 9	4-φ 11	4-φ 13	4-φ 17
D7	φ 46(22-70)	φ 70(45-90)	φ 70	φ 145(70-145)	φ 200(90-215)	φ 200(90-300)	φ 235(200-300)
D8	(4-M3X8L)	(4-M5X10L)	(4-M5X12L)	(4-M8X25L)	(4-M12X30L)	(4-M12X30L)	(4-M12X30L)
D9	M4X0.7P	M5X0.8P	M8X1.25P	M12X1.75P	M16X2.0P	M20X2.5P	M20X2.5P
L1	19	28.5	36.5	51	79	82	105
L2	5.5	7	10	12	15	20	30
L3	4	6	8	10	12	15	20
L4	26	37	48	65	97	105	138
L5	113	134	157	224	282	322	383
L6	139	171	205	(292)	(378)	(427)	(521)
L7	(3.5)	(5)	(5)	(11)	(14)	(15)	(7)
L8	(30)	(34)	(44)	(60)	(81)	(85)	(85)
L9	(69.5)	(81.5)	(107.5)	(134)	(165)	(213.5)	(268.5)
L10	(90.5)	(111.5)	(152.5)	(191.5)	(236)	(303.5)	(378.5)
C1	□42	□60	□90	□115	□142	□180	□220
C2	(□42)	(□60)	(□90)	(□130)	(□142)	(□180)	(□220)
S1	2	2	2	5	5	5	7
S2	16	25	32	40	65	70	90
S3	15	18	24.5	35	43	59	79
B	5	5	6	10	12	16	20
K1	-	4	6	8	10	14	16
K2	-	φ 11	φ 22	φ 28	φ 38	φ 50	φ 60
K3	-	12.7	25	31.3	42	53.8	64.4
K4	-	φ 16	φ 32	φ 38	φ 48	φ 60	φ 72
K5	-	15	20	27	35	43	60
K6	-	18	24	32	40	50	65

Note 1: Inside of ( ) is the optional range of sizes, outside of ( ) is the standard sizes.

Note 2: The reducer output shaft size and length can be customized for customers.

Note 3: The input size can be changed according to the servomotor or stepper motor of each brand.

# Precision Planetary Gearbox

## VRSF

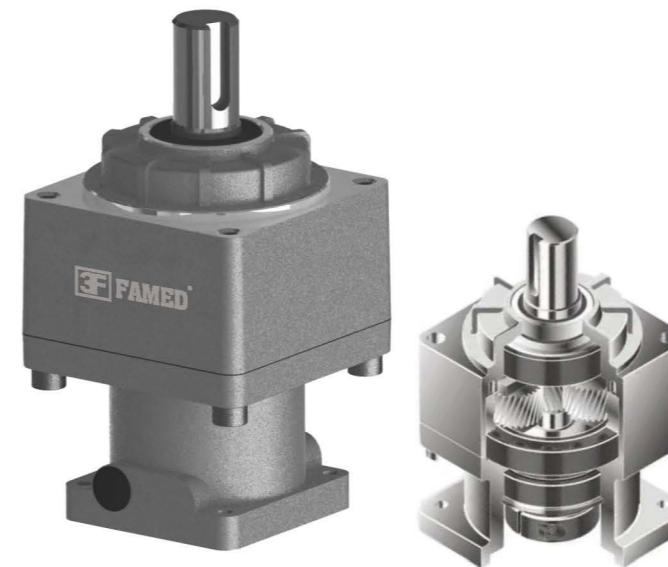

- 1. Quiet operation  
Helical gears are used to achieve smooth and quiet operation.
- 2. High precision  
The backlash is less than 3 arcmin and the positioning is accurate.
- 3. High rigidity & torque  
The use of integral ball bearings greatly improves the rigidity and torque.
- 4. Methods of flange and connector  
It can be installed on any motor in the world.
- 5. No grease leakage  
The use of grease with high viscosity which is not easy to separate effectively prevents the grease leakage.
- 6. Convenient maintenance  
No need to replace the grease in the product life period, and the installation is more convenient.

## Model Selection of Speed Reducers

### VRST Type

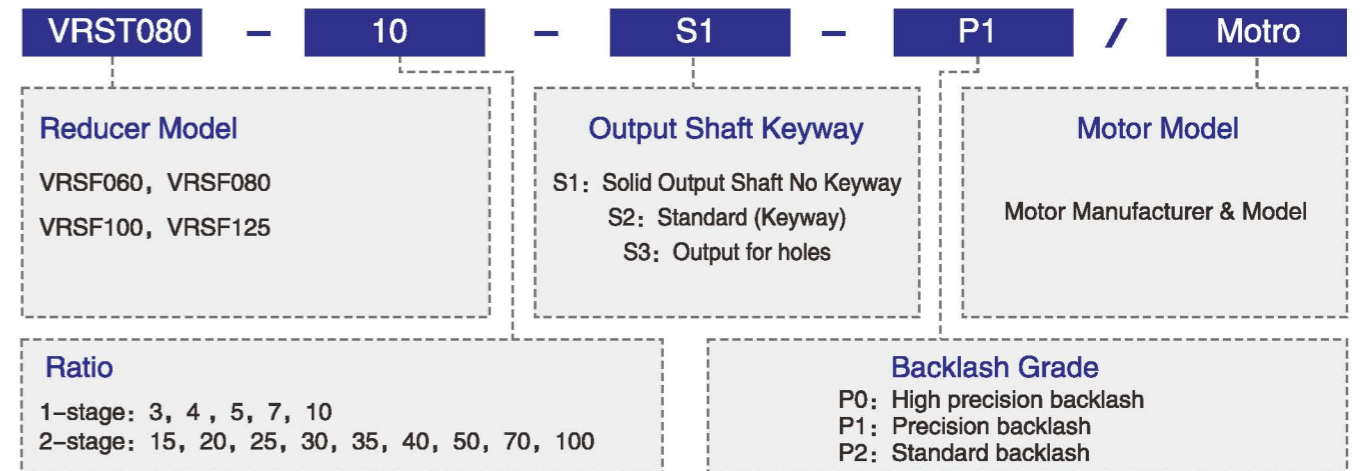

The gearbox matching motor needs to be confirmed with following dimensions :

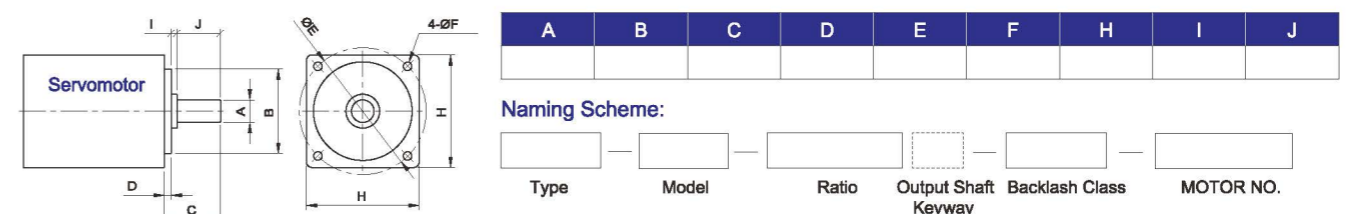

## VRSF Reducer Specifications

Specs	Unit	Stage	Ratio	VRSF060	VRSF080	VRSF100	VRSF125
Rated Output Torque / T2N	Nm	1	3	54	112	165	286
			4	48	110	146	255
			5	45	108	160	264
			7	41	105	149	245
			10	40	100	141	234
		2	15	54	112	165	286
			20	48	110	146	255
			25	45	108	160	264
			30	41	112	165	286
			35	41	105	149	245
			40	39	110	146	255
			50	45	108	160	264
			70	41	105	149	245
			100	40	100	141	234
Max. Output Torque / T2NOT <sup>1</sup>	Nm	1,2	3~100	3Times of Nominal Output Torque			
Rated Input Speed / Π1N	rpm	1,2	3~100	3000	3000	3000	3000
Max. Input Speed / Π1B	rpm	1,2	3~100	5000	5000	5000	5000
Precision Backlash P1	arcmin	1	3~10	≤5	≤5	≤5	≤5
		2	12~100	≤7	≤7	≤7	≤7
Standard Backlash P2	arcmin	1	3~10	≤8	≤8	≤8	≤8
		2	12~100	≤10	≤10	≤10	≤10
Torsional Rigidity	Nm/arcmin	1,2	3~100	5	12	14	23
Max. Radial Force / F2r <sup>2</sup>	N	1,2	3~100	800	1200	3200	5220
Max. Axial Force / F2a1 <sup>2</sup>	N	1,2	3~100	400	600	1600	2600
Service Life	hr	1,2	3~100	21000 h			
Efficiency / η	%	1	3~10	≥97%			
		2	15~100	≥94%			
Weight	kg	1	3~10	1.2	1.6	3.76	7.43
		2	15~100	2.1	2.8	5.92	10.3
Operating Temperature	°C	1,2	3~100	-25°C~+90°C			
Lubrication		1,2	3~100	Synthetic Grease			
Protection Class		1,2	3~100	Any Direction			
Mounting Position		1,2	3~100				
Noise Level (n1=3000rpm, No load)	dB(A)	1,2	3~100	≤60	≤62	≤65	≤67

## Reducer Rotary Inertia

Specs	Unit	Stage	Ratio	VRSF060	VRSF080	VRSF100	VRSF125	
Moment of Inertia	kg.cm <sup>2</sup>	1	3	0.16	0.61	3.25	9.21	
			4	0.14	0.48	2.74	7.54	
			5	0.13	0.47	2.71	7.42	
			6	0.13	0.45	2.65	7.25	
			7	0.13	0.45	2.62	7.14	
			8	0.13	0.44	2.58	7.07	
			9	0.13	0.44	2.57	7.04	
			10	0.13	0.44	2.57	7.03	
			2	12~40	0.03	0.13	0.47	2.71
				50~100	0.03	0.13	0.44	2.57

- Ratio (i=Nin/Nout) 2. The Max. acceleration torque T2B=60% of T2NOT
- When output speed is 100rpm, inertia acts on the output shaft center position. continuous operation, service life is 15000hrs.

# MODEL: VRSF

1-Stage  
Ratio: 3, 4, 5, 7, 10

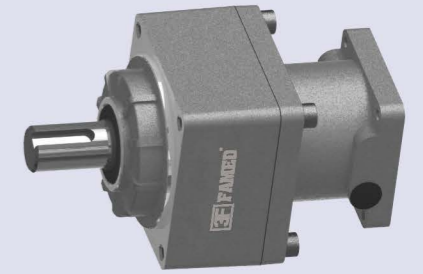

## Dimensions

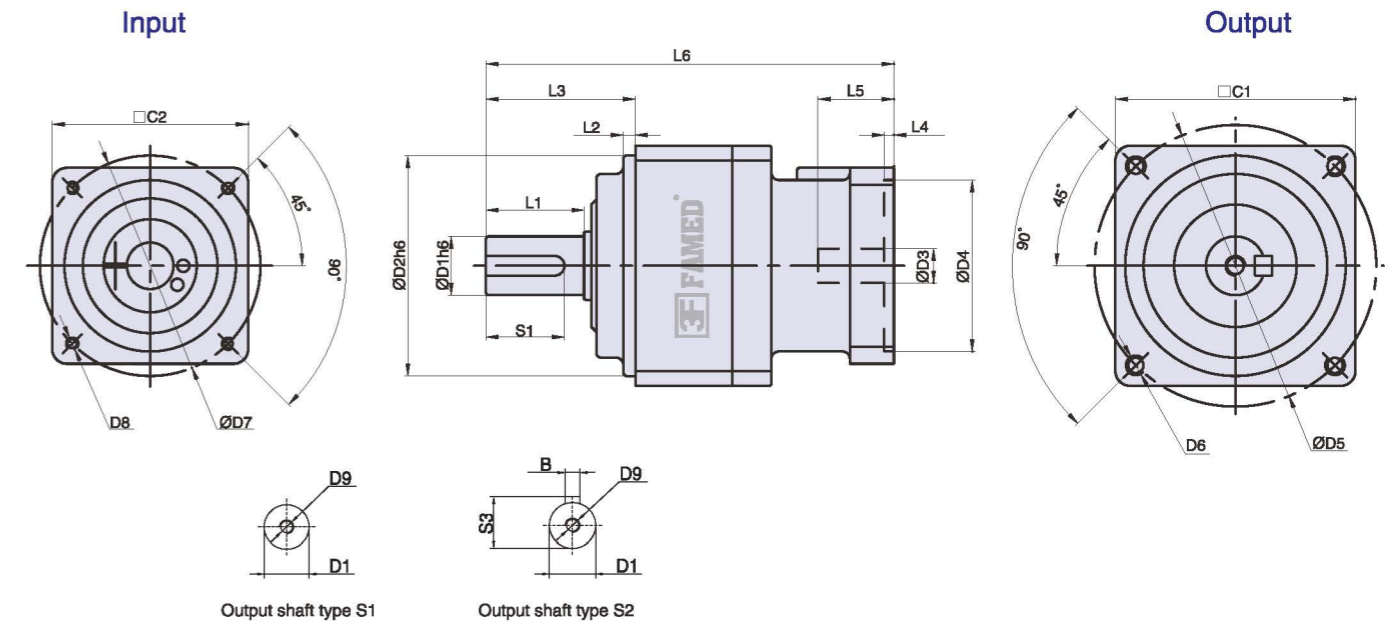

Unit:mm

Size	VRSF060-L1	VRSF080-L1	VRSF100-L1	VRSF125-L1
D1	12	19	24	32
D2	50	70	90	110
D3	8(8~14)	14(14~19)	19	22(22~24)
D4	30(30~50)	50(50~70)	70	110
D5	60	90	115	135
D6	M5	M6	M8	M10
D7	45(45~70)	70(70~90)	90	145
D8	M4~M5	M4~M5	M6	M8
D9	M4	M6	M8	M12
L1	20	30	40	55
L2	3	3	5	5
L3	32	50	61	75
L4	4	4	4	8
L5	27~32	32	38	65.5
L6	109	143.5~148.5	177	215.5
C1	52	78	98	125
C2	40(40~52)	60(60~80)	90	125(125~130)
S1	18	22	32	52
S2	13.5	21.5	27	35
B	4	6	6	10

- Note 1: Inside of () is the optional range of sizes, outside of () is the standard sizes.  
 Note 2: The reducer output shaft size and length can be customized for customers.  
 Note 3: The input size can be changed according to the servomotor or stepper motor of each brand.

# MODEL: VRSF

2-Stage

Ratio: 15, 20, 25, 30, 35, 40, 50, 70, 100

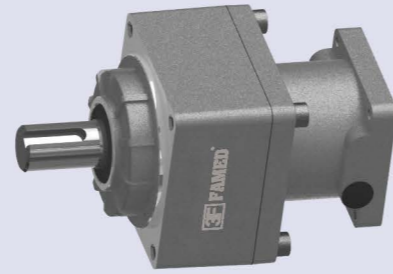

## Dimensions:

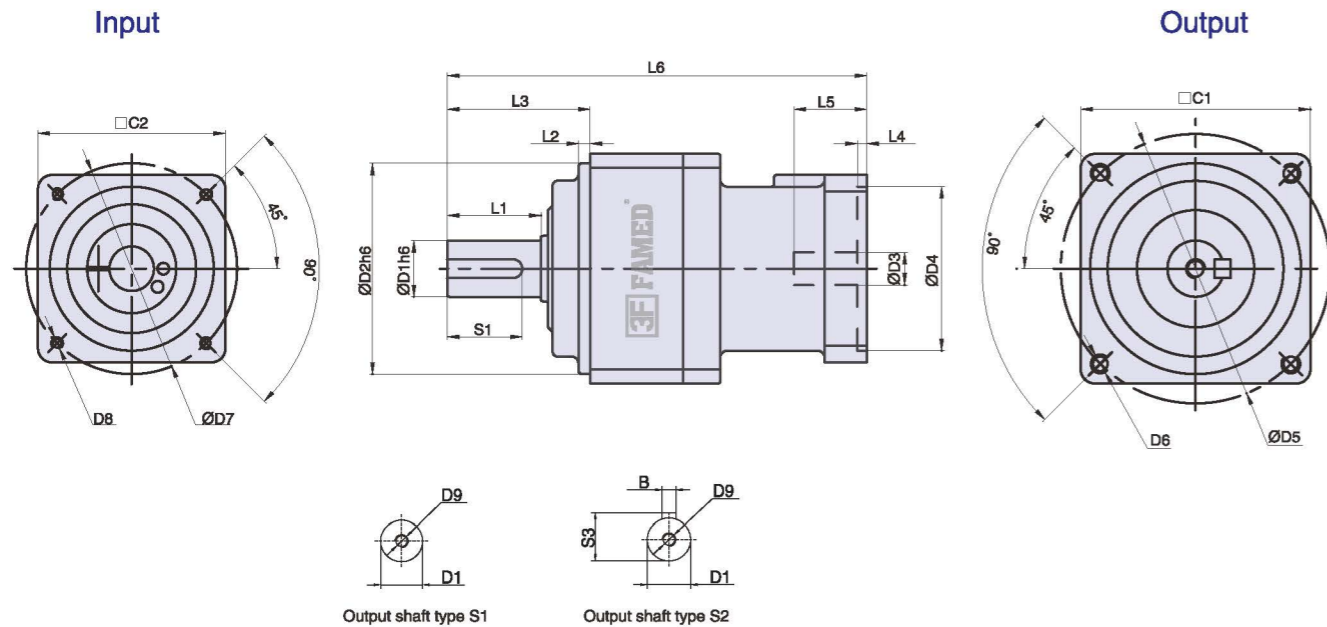

Unit:mm

Size	VRSF060-L2	VRSF080-L2	VRSF100-L2	VRSF125-L2
D1	12	19	24	32
D2	50	70	90	110
D3	11(11 ~ 14)	14(14 ~ 19)	14 ~ 19	22(22 ~ 24)
D4	50	50(50 ~ 70)	50(50 ~ 70)	110
D5	60	90	115	135
D6	M5	M6	M8	M10
D7	45(45 ~ 70)	70(70 ~ 90)	70 ~ 90	145
D8	M4 ~ M5	M4 ~ M5	M4 ~ M5	M8
D9	M4	M6	M8	M12
L1	20	30	40	55
L2	3	3	5	5
L3	32	50	61	75
L4	4	4	4	8
L5	32	32	38	65.5
L6	109	150 ~ 155	165 ~ 179	250.5
C1	52	78	98	125
C2	52	60(60 ~ 80)	60(60 ~ 80)	125(125 ~ 130)
S1	18	22	32	52
S2	13.5	21.5	27	35
B	4	6	8	10

Note 1: Inside of ( ) is the optional range of sizes, outside of ( ) is the standard sizes.

Note 2: The reducer output shaft size and length can be customized for customers.

Note 3: The input size can be changed according to the servomotor or stepper motor of each brand.

# Precision Planetary Gearbox

FB



- 1. Quiet operation  
Helical gears are used to achieve smooth and quiet operation.
- 2. High precision  
The backlash is less than 3 arcmin and the positioning is accurate.
- 3. High rigidity & torque  
The use of integral ball bearings greatly improves the rigidity and torque.
- 4. Methods of flange and connector  
It can be installed on any motor in the world.
- 5. No grease leakage  
The use of grease with high viscosity which is not easy to separate effectively prevents the grease leakage.
- 6. Convenient maintenance  
No need to replace the grease in the product life period, and the installation is more convenient.

## Model Selection of Speed Reducers

### FB Type

FB090 - 10 - S1 - P1 / Motor

<b>Reducer Model</b> FB040, FB060, FB090 FB120, FB160	<b>Output Shaft Keyway</b> S1: Solid Output Shaft No Keyway S2: Standard (Keyway) S3: Output for holes	<b>Motor Model</b> Motor Manufacturer & Model
<b>Ratio</b> 1-stage: 3, 4, 5, 6, 7, 8, 9, 10 2-stage: 12, 15, 16, 20, 25, 28, 30, 35, 40, 50, 70, 80, 100 3-stage: 60, 64, 72, 80, 90, 100, 120, 144, 150, 160, 180, 200, 240, 258, 288, 320, 384, 512, 600, 800, 1000	<b>Backlash Grade</b> P0: High precision backlash P1: Precision backlash P2: Standard backlash	

The gearbox matching motor needs to be confirmed with following dimensions :

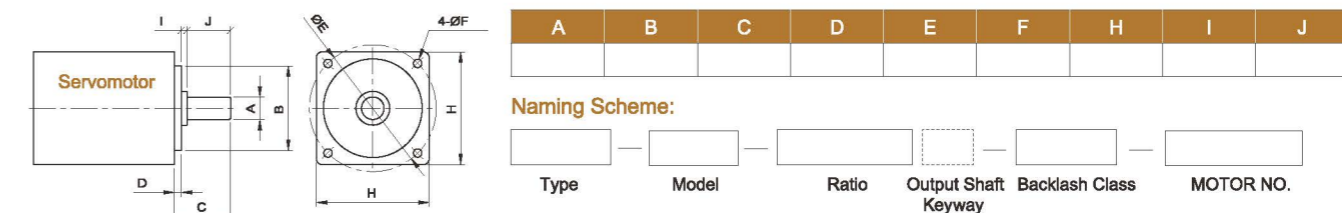

# FB Reducer Specifications

Specs	Unit	Stage	Ratio	FB040	FB060	FB090	FB120	FB160
Rated Output Torque / T2N	Nm	1	3	16	45	125	245	615
			4	17	50	135	298	650
			5	18	55	150	300	688
			7	15	50	145	245	645
			10	13	45	135	205	498
		2	15	16	45	120	198	615
			20	16	50	135	245	650
			25	18	55	150	300	688
			30	14	45	125	245	615
			35	18	55	150	300	688
			40	13	50	135	298	650
			50	17	55	140	265	688
		100	14	45	130	256	645	
			13	40	115	205	498	
Max.Output Torque / T <sub>2NOT</sub> <sup>1</sup>	Nm	1,2	3~100	3Times of Nominal Output Torque				
Rated Input Speed / Π <sub>1N</sub>	rpm	1,2	3~100	3000	3000	3000	3000	2500
Max.Input Speed / Π <sub>1s</sub>	rpm	1,2	3~100	5000	5000	5000	5000	3600
Precision Backlash P1	arcmin	1	3~10	≤3	≤3	≤3	≤3	≤3
		2	12~100	≤5	≤5	≤5	≤5	≤5
Standard Backlash P2	arcmin	1	3~10	≤5	≤5	≤5	≤5	≤5
		2	12~100	≤7	≤7	≤7	≤7	≤7
Torsional Rigidity	Nm/arcmin	1,2	3~100	3	6	12	22	50
Max.Radial Force / F <sub>2r</sub> <sup>2</sup>	N	1,2	3~100	320	460	1300	3200	6520
Max.Axial Force / F <sub>2a</sub> <sup>2</sup>	N	1,2	3~100	160	230	660	1600	3260
Service Life	hr	1,2	3~100	20000 h				
Efficiency / η	%	1	3~10	≥97%				
		2	15~100	≥94%				
Weight	kg	1	3~10	0.73	0.99	2.1	4.98	18.2
		2	15~100	1.05	1.46	3.2	6.92	24.9
Operating Temperature	°C	1,2	3~100	-25°C~+90°C				
Lubrication		1,2	3~100	Synthetic Grease				
Protection Class		1,2	3~100	IP65				
Mounting Position		1,2	3~100	Any				
Noise Level (n1=3000rpm, No load)	dB(A)	1,2	3~100	≤62	≤63	≤65	≤67	≤68

## Reducer Rotary Inertia

Specs	Unit	Stage	Ratio	FB040	FB060	FB090	FB120	FB160
Moment of Inertia	kg.cm <sup>2</sup>	1	3	0.03	0.16	0.61	3.25	9.21
			4	0.03	0.14	0.48	2.74	7.54
			5	0.03	0.13	0.47	2.71	7.42
			7	0.03	0.13	0.45	2.65	7.25
			10	0.03	0.13	0.45	2.62	7.14
		2	12~40	0.03	0.13	0.44	2.58	7.07
			50~100	0.03	0.13	0.44	2.57	7.04

- Ratio (i=Nin/Nout)
- Output revolutions 100rpm, acting on the output shaft center position.
- \*Continuous operation, service life is 10000hrs.

# MODEL: FB

1-Stage

Ratio: 3, 4, 5, 6, 7, 8, 9, 10



## Dimensions:

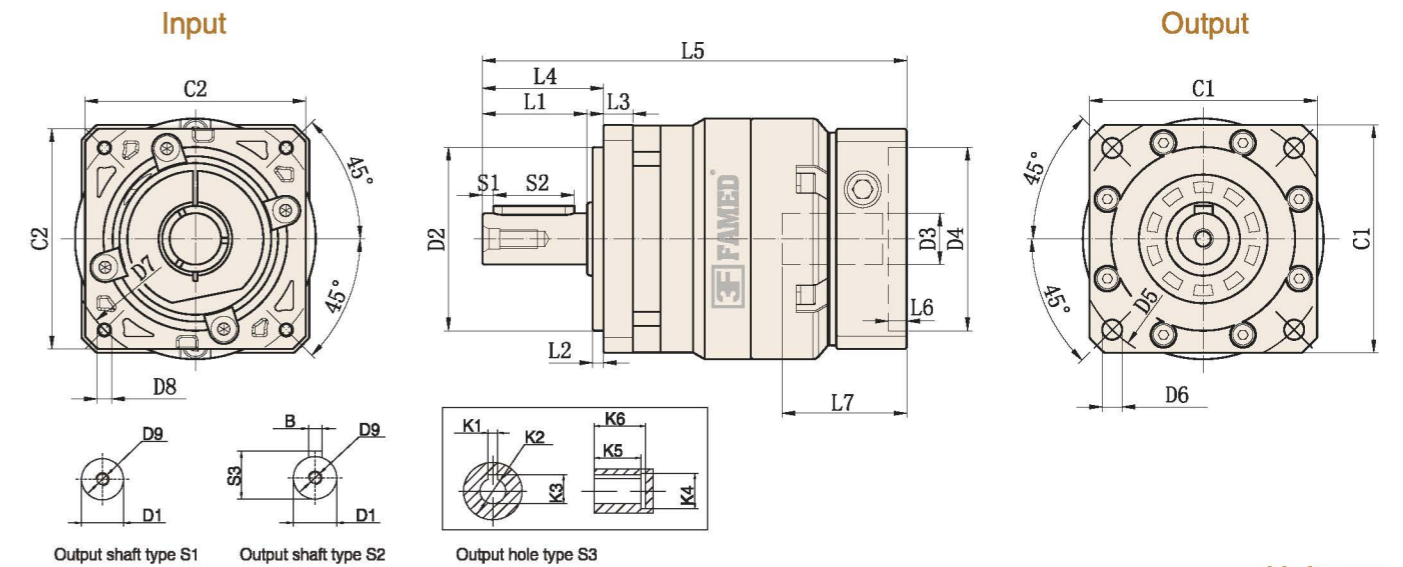

Unit:mm

Size	FB040-L1	FB060-L1	FB090-L1	FB120-L1	FB160-L1
D1	φ 12(13)	φ 14(16)	φ 20(22)	φ 25(32)	φ 40
D2	φ 26	φ 50	φ 80	φ 110	φ 130
D3	φ 8(≤11)	φ 14(≤19)	φ 19(≤24)	φ 24(≤32)	φ 35(42)
D4	φ 30(30~50)	φ 50 ( 50~70 )	φ 70 ( 50~110 )	φ 110(70~130)	φ 114.3(110~150)
D5	φ 48	φ 70	φ 100	φ 130	φ 185(165)
D6	4-φ 3.4	4-φ 5.5	4-φ 7	4-φ 9	4-φ 11
D7	φ 46(45~70)	φ 70 ( 70~130 )	φ 90 ( 70~145 )	φ 145(90~165)	φ 200(145~220)
D8	(4-M4X8L)	( 4-M4*10L )	( 4-M5*12L )	(4-M8X25L)	(4-M12X25L)
D9	M4X0.7P	M5*0.8P*15L	M6*1.0P*16.5L	M10X1.5P	M16X2.0P
L1	18	28.5	36.5	50	80
L2	3	3	3	4	5
L3	4	8	10	15	16
L4	22.5	33	40.5	55	87
L5	( 5 )	(115.5)	(147)	( 8 )	( 7 )
L6	( 32 )	(5)	(6.5)	( 59 )	( 86 )
L7	( 88 )	(34)	(42)	( 211 )	( 292 )
C1	□45	□62	□90	□124	□175
C2	(□50)	( □60 )	( □80 )	(□120)	(□176)
S1	2	3	4	5	8
S2	14	22	28	40	65
S3	13.5	16	22.5	28	43
B	4	5	6	8	12
K1	-	3	6	8	10
K2	-	φ 8	φ 18	φ 25	φ 35
K3	-	9.2	21	28	38.3
K4	-	φ 11	φ 24	φ 32	φ 42
K5	-	20	30	40	52
K6	-	24	35	48	58

Note 1: Inside of ( ) is the optional range of sizes, outside of ( ) is the standard sizes.

Note 2: The reducer output shaft size and length can be customized for customers.

Note 3: The input size can be changed according to the servomotor or stepper motor of each brand.

# MODEL: FB

2-Stage

Ratio: 12, 15, 16, 20, 25, 28, 30, 35, 40, 50  
70, 80, 100



## Dimensions:

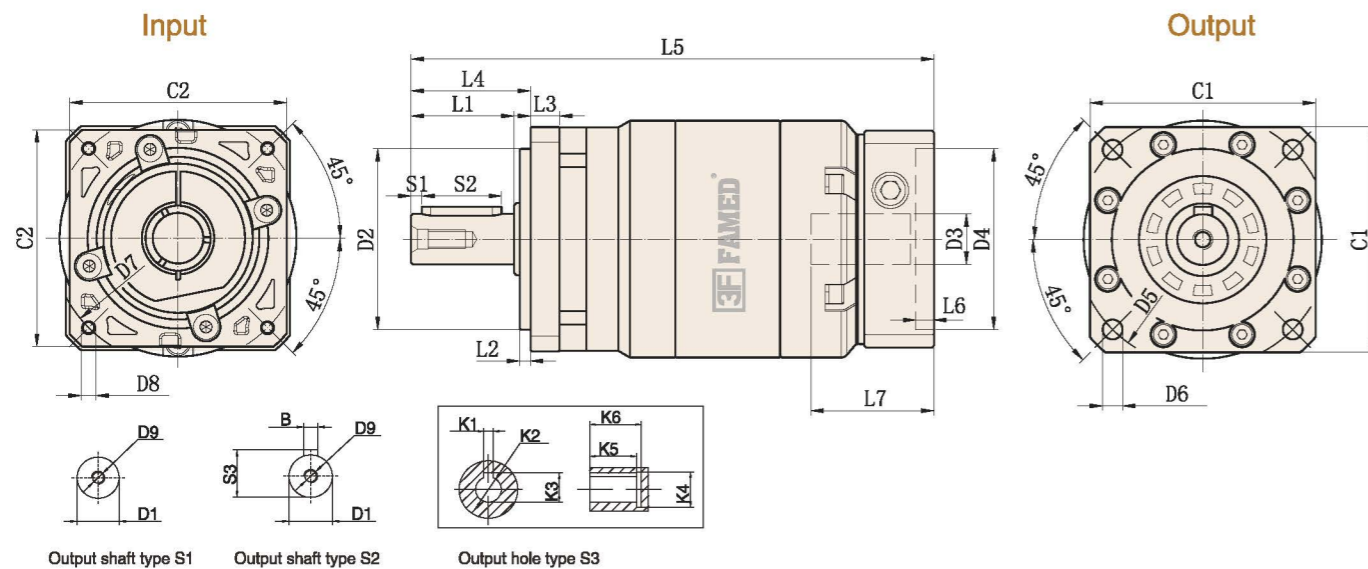

Unit:mm

Size	FB040-L2	FB060-L2	FB090-L2	FB120-L2	FB160-L2
D1	φ 12(13)	φ 14(16)	φ 20(22)	φ 25(32)	φ 40
D2	φ 26	φ 50	φ 80	φ 110	φ 130
D3	φ 8(≤11)	φ 14(≤19)	φ 19(≤24)	φ 24(≤32)	φ 35(42)
D4	φ 30(30-50)	φ 50 ( 50-70 )	φ 70 ( 50-110 )	φ 110 ( 70-130 )	φ 114.3(110-150)
D5	φ 48	φ 70	φ 100	φ 130	φ 185(165)
D6	4-φ 3.4	4-φ 5.5	4-φ 7	4-φ 9	4-φ 11
D7	φ 46(45-70)	φ 70 ( 70-130 )	φ 90 ( 70-145 )	φ 145 ( 90-165 )	φ 200(145-220)
D8	(4-M4X8L)	( 4-M4*10L )	( 4-M5*12L )	( 4-M8*20L )	(4-M12X25L)
D9	M4X0.7P	M5*0.8P*15L	M6*1.0P*16.5L	M10*1.5P*23L	M16X2.0P
L1	18	28.5	36.5	50	80
L2	3	3	3	4	5
L3	4	8	10	15	16
L4	22.5	33	40.5	55	87
L5	( 5 )	(144.5)	(177.5)	(232.5)	( 7 )
L6	( 32 )	(5)	(6.5)	(11)	( 86 )
L7	( 105 )	(34)	(42)	(59)	( 295 )
C1	□45	□62	□90	□120	□175
C2	(□50)	( □60 )	( □80 )	( □130 )	(□176)
S1	2	3	4	5	8
S2	14	22	28	40	65
S3	13.5	16	22.5	28	43
B	4	5	6	8	12
K1	-	3	6	8	10
K2	-	φ 8	φ 18	φ 25	φ 35
K3	-	9.2	21	28	38.3
K4	-	φ 11	φ 24	φ 32	φ 42
K5	-	20	30	40	52
K6	-	24	35	48	58

Note 1: Inside of ( ) is the optional range of sizes, outside of ( ) is the standard sizes.

Note 2: The reducer output shaft size and length can be customized for customers.

Note 3: The input size can be changed according to the servomotor or stepper motor of each brand.

# Precision Right Angle Planetary Gearbox

## FBR



- 1. Space-saving  
The straight cross reducer uses spiral bevel gear. The installation of the motor can achieve 90 degree bending and save the installation space.
- 2. High rigidity & torque  
The use of integral ball bearings greatly improves the rigidity and torque.
- 3. Connector and shaft sleeve mode  
It can be installed on any motor in the world.
- 4. No grease leakage  
The use of grease with high viscosity which is not easy to separate effectively prevents the grease leakage.
- 5. Convenient maintenance  
No need to replace the grease in the product life period, and the installation is more convenient.

## Model Selection of Speed Reducers

### FBR Type

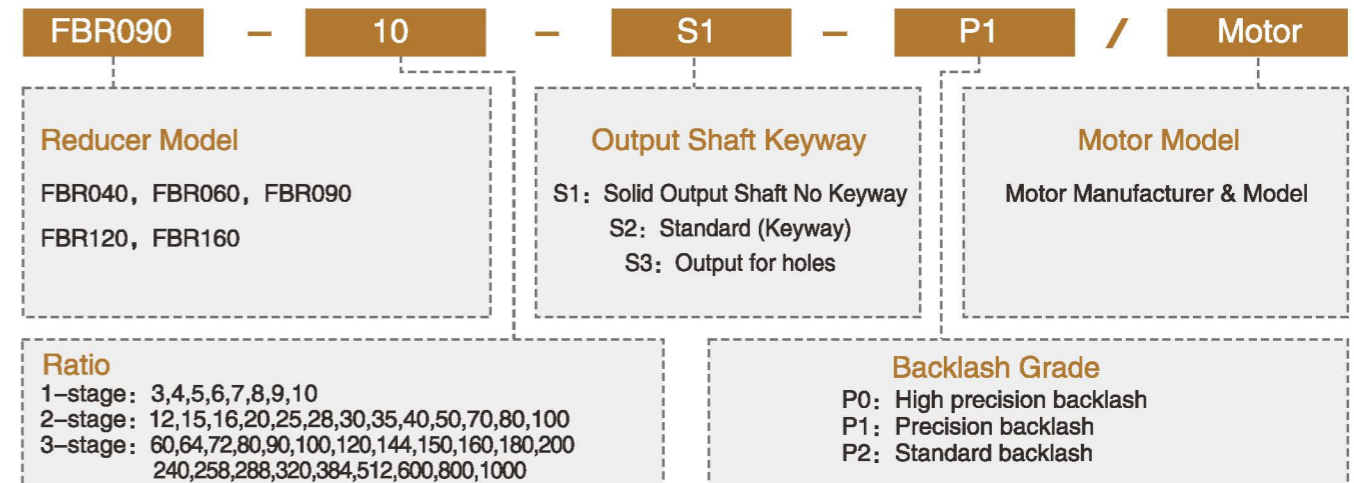

The gearbox matching motor needs to be confirmed with following dimensions :

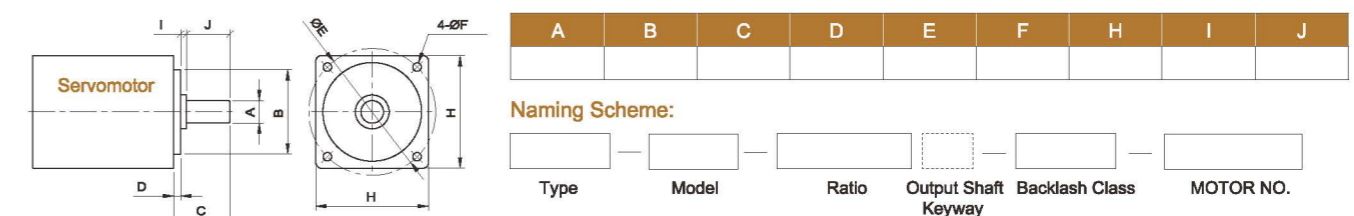

## FBR Reducer Specifications

Specs	Unit	Stage	Ratio	FBR040	FBR060	FBR090	FBR120	FBR160
Rated Output Torque / T <sub>2N</sub>	Nm	1	3	16	45	125	245	615
			4	17	50	135	298	650
			5	18	55	150	300	688
			7	15	50	145	245	645
			10	13	45	135	205	498
		2	15	16	45	120	198	615
			20	16	50	135	245	650
			25	18	55	150	300	688
			30	14	45	125	245	615
			35	18	55	150	300	688
			40	13	50	135	298	650
			50	17	55	140	265	688
			70	14	45	130	256	645
			100	13	40	115	205	498
Max.Output Torque / T <sub>2N</sub> <sup>1</sup>	Nm	1,2	3~100	3Times of Nominal Output Torque				
Rated Input Speed / Π <sub>IN</sub>	rpm	1,2	3~100	3000	3000	3000	3000	2500
Max.Input Speed / Π <sub>IN</sub>	rpm	1,2	3~100	5000	5000	5000	5000	3600
Precision Backlash P1	arcmin	1	3~10	≤8	≤8	≤8	≤8	≤8
		2	12~100	≤10	≤10	≤10	≤10	≤10
Standard Backlash P2	arcmin	1	3~10	≤11	≤11	≤11	≤11	≤11
		2	12~100	≤13	≤13	≤13	≤13	≤13
Torsional Rigidity	Nm/arcmin	1,2	3~100	3	6	12	22	50
Max.Radial Force / F <sub>2R</sub> <sup>2</sup>	N	1,2	3~100	320	460	1300	3200	6520
Max.Axial Force / F <sub>2A</sub> <sup>2</sup>	N	1,2	3~100	160	230	660	1600	3260
Service Life	hr	1,2	3~100	20000 h				
Efficiency / η	%	1	3~10	≥97%				
		2	15~100	≥94%				
Weight	kg	1	3~10	0.73	0.99	2.1	4.98	18.2
		2	15~100	1.05	1.46	3.2	6.92	24.9
Operating Temperature	°C	1,2	3~100	-25°C~+90°C				
Lubrication		1,2	3~100	Synthetic Grease				
Protection Class		1,2	3~100	IP65				
Mounting Position		1,2	3~100	Any Direction				
Noise Level (n1=3000rpm, No load)	dB(A)	1,2	3~100	≤62	≤63	≤65	≤67	≤68

## Reducer Rotary Inertia

Specs	Unit	Stage	Ratio	FBR040	FBR060	FBR090	FBR120	FBR160
Moment of Inertia	kg.cm <sup>2</sup>	1	3	0.03	0.16	0.61	3.25	9.21
			4	0.03	0.14	0.48	2.74	7.54
			5	0.03	0.13	0.47	2.71	7.42
			7	0.03	0.13	0.45	2.65	7.25
			10	0.03	0.13	0.45	2.62	7.14
		2	12~40	0.03	0.13	0.44	2.58	7.07
			50~100	0.03	0.13	0.44	2.57	7.04

- The Max. acceleration torque T<sub>2B</sub>=60%
- When output speed is 100rpm, acting on the output shaft center position
- 3-stage big ratios are not in the above table. There is shaft lengthening and enlarging design. Please tell sales person if you need it.

## MODEL: FBR

1-Stage

Ratio: 3, 4, 5, 6, 7, 8, 9, 10



### Dimensions:

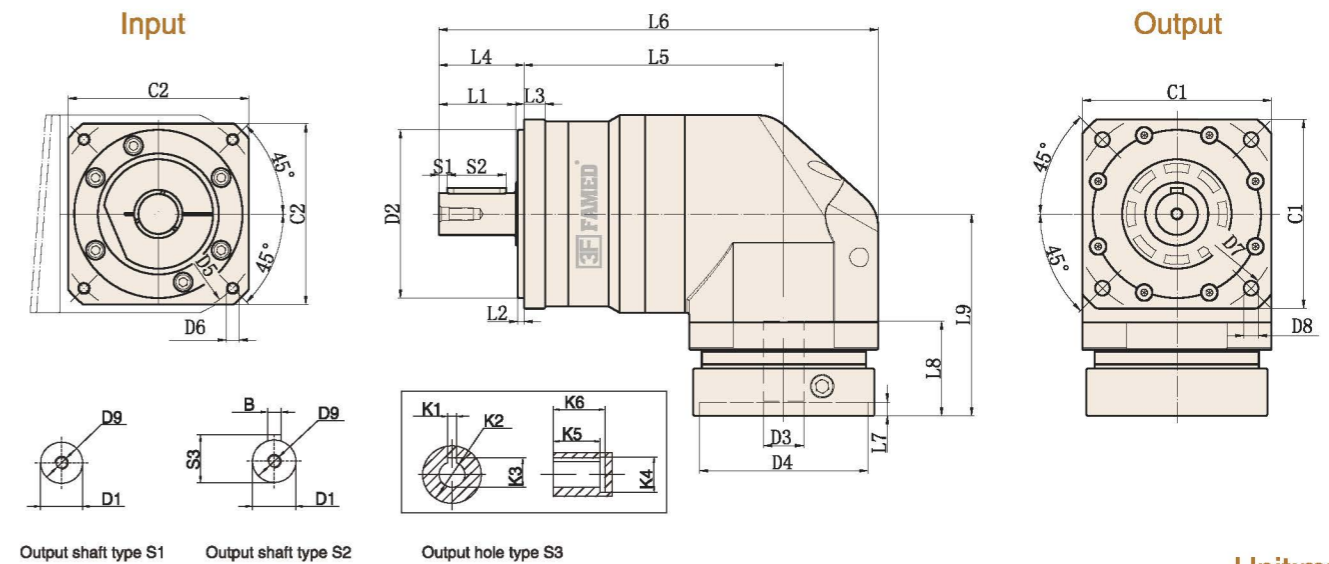

Unit:mm

Size	FBR060-L1	FBR090-L1	FBR120-L1	FBR160-L1
D1	φ 14	φ 20 ( 22 )	φ 25	φ 40
D2	φ 50	φ 80	φ 110	φ 130
D3	φ 14(6.35-19)	φ 19 ( φ 11-24 )	φ 22(16-24)	φ 35 ( φ 22-38 )
D4	φ 50 ( 50-70 )	φ 80 ( 50-110 )	φ 80 ( 50-110 )	φ 114.3 ( φ 110-114.3 )
D5	φ 70 ( 70-130 )	φ 100 ( 70-145 )	φ 145 ( 90-155 )	φ 200 ( φ 145-200 )
D6	( 4-M4*10L )	( 4-M6*14L )	( 4-M8*20L )	4-M12 ( M8-M12 )
D7	φ 70	φ 100	φ 130	φ 185
D8	4- φ 5.5	4- φ 7	4- φ 9	4- φ 11
D9	M5*0.8P*15L	M6*1.0P*16.5L	M10*1.5P*23L	M16X2P
L1	28.5	36.5	50	87
L2	3	3	4	78
L3	8	10	15	5
L4	33	40.5	55	20
L5	90	123.5	146.5	111
L6	153	209	259	295
L7	(5)	(6.5)	(10)	5 ( 5-7 )
L8	(33)	(45)	(64)	86 ( 62-86 )
L9	(77.5)	(96)	(135.5)	165.5 ( 165.5-189.5 )
C1	□62	□90	□120	□160
C2	( □60 )	( □86 )	( □130 )	□175 ( 142 )
S1	3	4	5	5
S2	22	28	40	70
S3	16	22.5	28	43
B	5	6	8	12
K1	3	6	8	10
K2	φ 8	φ 18	φ 28	φ 38
K3	9.2	21	31.3	41.3
K4	φ 11	φ 24	φ 38	φ 48
K5	20	30	27	35
K6	24	35	32	40

# MODEL: FBR

2-Stage

Ratio: 12, 15, 16, 20, 25, 28, 30, 35, 40, 50  
70, 80, 100



## Dimensions:

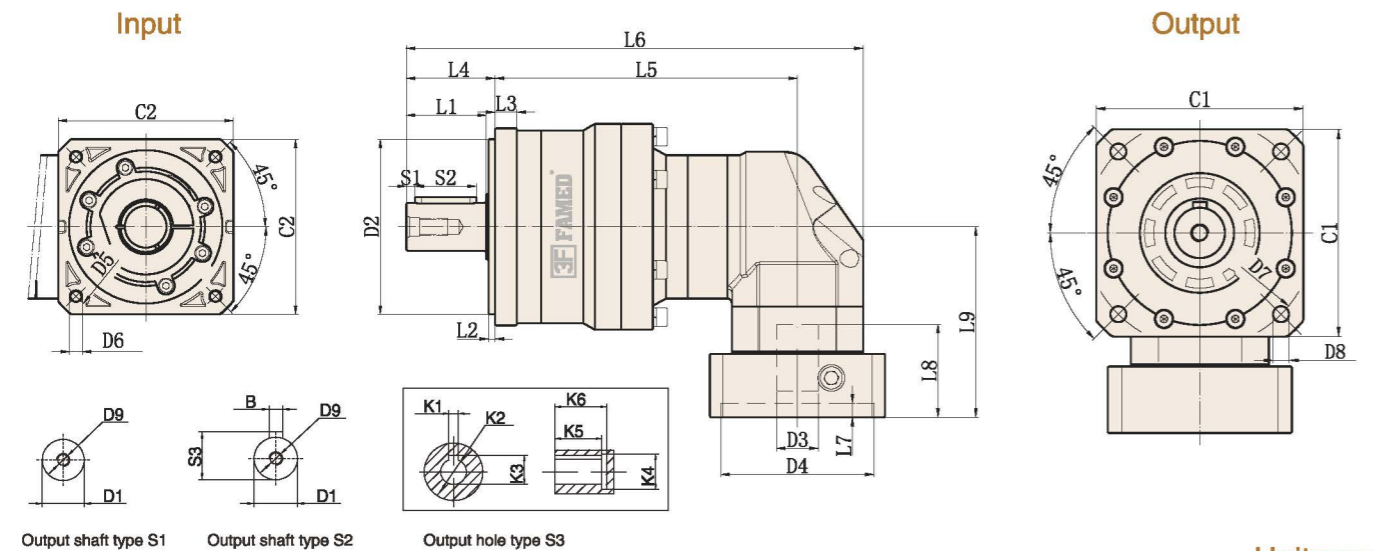

Size	FBR060-L2	FBR090-L2	FBR120-L2	FBR160-L2
D1	φ 14	φ 20 ( 22 )	φ 25 ( 32 )	φ 40
D2	φ 50	φ 80	φ 110	φ 130
D3	φ 19(6.35-19)	φ 19 ( φ 11-24 )	φ 22 ( φ 16-24 )	φ 35 ( φ 22-38 )
D4	φ 70 ( 50-70 )	φ 70 ( 50-110 )	φ 110 ( φ 55.5-110 )	φ 114.3 ( φ 110-114.3 )
D5	φ 90 ( 70-130 )	φ 90 ( 70-145 )	φ 145 ( φ 90-155 )	φ 200 ( φ 145-200 )
D6	( 4-M4*10L)	( 4-M6*14L)	4-M8 ( M6-M12 )	4-M12 ( M8-M12 )
D7	φ 70	φ 100	φ 130	φ 185
D8	4-φ 5.5	4-φ 7	4-φ 8.5	4-φ 11
D9	M5*0.8P*15L	M6*1.0P*16.5L	M10X1.5P	M16X2P
L1	28.5	36.5	55	87
L2	3	3	49	78
L3	8	10	4	5
L4	33	40.5	15	20
L5	119	138	110	149
L6	182	208.5	303	333
L7	(6.5)	(6.5)	8(5-8)	5 ( 5-7 )
L8	(42.5)	(42.5)	70 ( 59-70 )	86 ( 62-86 )
L9	(87)	(87)	130 ( 119-130 )	165.5 ( 165.5-189.5 )
C1	□62	□90	□120	□160
C2	( □80 )	( □86 )	130 ( 120 )	175 ( 142 )
S1	3	4	5	5
S2	22	28	40	70
S3	16	22.5	28	43
B	5	6	8	12
K1	3	6	8	10
K2	φ 8	φ 18	φ 28	φ 38
K3	9.2	21	31.3	41.3
K4	φ 11	φ 24	φ 38	φ 48
K5	20	30	27	35
K6	24	35	32	40

# Precision Planetary Gearbox

## FE



- 1. Quiet operation  
Helical gears are used to achieve smooth and quiet operation.
- 2. High precision  
The backlash is less than 3 arcmin and the positioning is accurate.
- 3. High rigidity & torque  
The use of integral ball bearings greatly improves the rigidity and torque.
- 4. Methods of flange and connector  
It can be installed on any motor in the world.
- 5. No grease leakage  
The use of grease with high viscosity which is not easy to separate effectively prevents the grease leakage.
- 6. Convenient maintenance  
No need to replace the grease in the product life period, and the installation is more convenient.

## Model Selection of Speed Reducers

### FE Type

FE090 - 10 - S1 - P1 / Motor

#### Reducer Model

FE040, FE060, FE090  
FE120, FE160

#### Output Shaft Keyway

S1: Solid Output Shaft No Keyway  
S2: Standard (Keyway)  
S3: Output for holes

#### Motor Model

Motor Manufacturer & Model

#### Ratio

1-stage: 3, 4, 5, 6, 7, 8, 9, 10  
2-stage: 12, 15, 16, 20, 25, 28, 30, 35, 40, 50, 70, 80, 100  
3-stage: 60, 64, 72, 80, 90, 100, 120, 144, 150, 160, 180, 200, 240, 258, 288, 320, 384, 512, 600, 800, 1000

#### Backlash Grade

P0: High precision backlash  
P1: Precision backlash  
P2: Standard backlash

The gearbox matching motor needs to be confirmed with following dimensions :

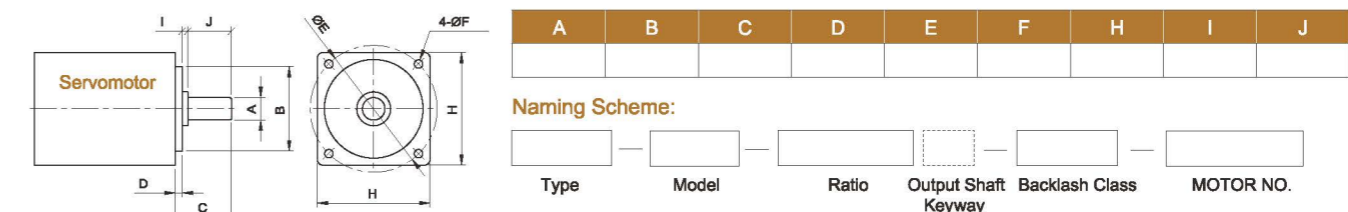

## FE Reducer Specifications

Specs	Unit	Stage	Ratio	FE040	FE060	FE090	FE120	FE160
Rated Output Torque / T <sub>2N</sub>	Nm	1	3	16	45	125	245	615
			4	17	50	135	298	650
			5	18	55	150	300	688
			7	15	50	145	245	645
			10	13	45	135	205	498
		2	15	16	45	120	198	615
			20	16	50	135	245	650
			25	18	55	150	300	688
			30	14	45	125	245	615
			35	18	55	150	300	688
			40	13	50	135	298	650
			50	17	55	140	265	688
			70	14	45	130	256	645
			100	13	40	115	205	498
Max.Output Torque / T <sub>2N</sub> <sup>1</sup>	Nm	1,2	3~100	3Times of Nominal Output Torque				
Rated Input Speed / Π <sub>1N</sub>	rpm	1,2	3~100	3000	3000	3000	3000	2500
Max.Input Speed / Π <sub>1B</sub>	rpm	1,2	3~100	5000	5000	5000	5000	3600
Precision Backlash P1	arcmin	1	3~10	≤3	≤3	≤3	≤3	≤3
		2	12~100	≤5	≤5	≤5	≤5	≤5
Standard Backlash P2	arcmin	1	3~10	≤5	≤5	≤5	≤5	≤5
		2	12~100	≤7	≤7	≤7	≤7	≤7
Torsional Rigidity	Nm/arcmin	1,2	3~100	3	6	12	22	50
Max.Radial Force / F <sub>2R</sub> <sup>2</sup>	N	1,2	3~100	320	460	1300	3200	6520
Max.Axial Force / F <sub>2A</sub> <sup>2</sup>	N	1,2	3~100	160	230	660	1600	3260
Service Life	hr	1,2	3~100	20000 h				
Efficiency / η	%	1	3~10	≥97%				
		2	15~100	≥94%				
Weight	kg	1	3~10	0.73	0.99	2.1	4.98	18.2
		2	15~100	1.05	1.46	3.2	6.92	24.9
Operating Temperature	℃	1,2	3~100	-25℃~+90℃				
Lubrication		1,2	3~100	Synthetic Grease				
Protection Class		1,2	3~100	IP65				
Mounting Position		1,2	3~100	Any Direction				
Noise Level (n1=3000rpm, No load)	dB(A)	1,2	3~100	≤62	≤63	≤65	≤67	≤68

## Reducer Rotary Inertia

Specs	Unit	Stage	Ratio	FE040	FE060	FE090	FE120	FE160
Moment of Inertia	kg.cm <sup>2</sup>	1	3	0.03	0.16	0.61	3.25	9.21
			4	0.03	0.14	0.48	2.74	7.54
			5	0.03	0.13	0.47	2.71	7.42
			7	0.03	0.13	0.45	2.65	7.25
			10	0.03	0.13	0.45	2.62	7.14
		2	12~40	0.03	0.13	0.44	2.58	7.07
			50~100	0.03	0.13	0.44	2.57	7.04

1. Ratio (i=Nin/Nout)      2. Output revolutions 100rpm, acting on the output shaft center position.  
3. \*Continuous operation, service life is 10000hrs.

# MODEL: FE

1-Stage

Ratio: 3, 4, 5, 6, 7, 8, 9, 10



## Dimensions:

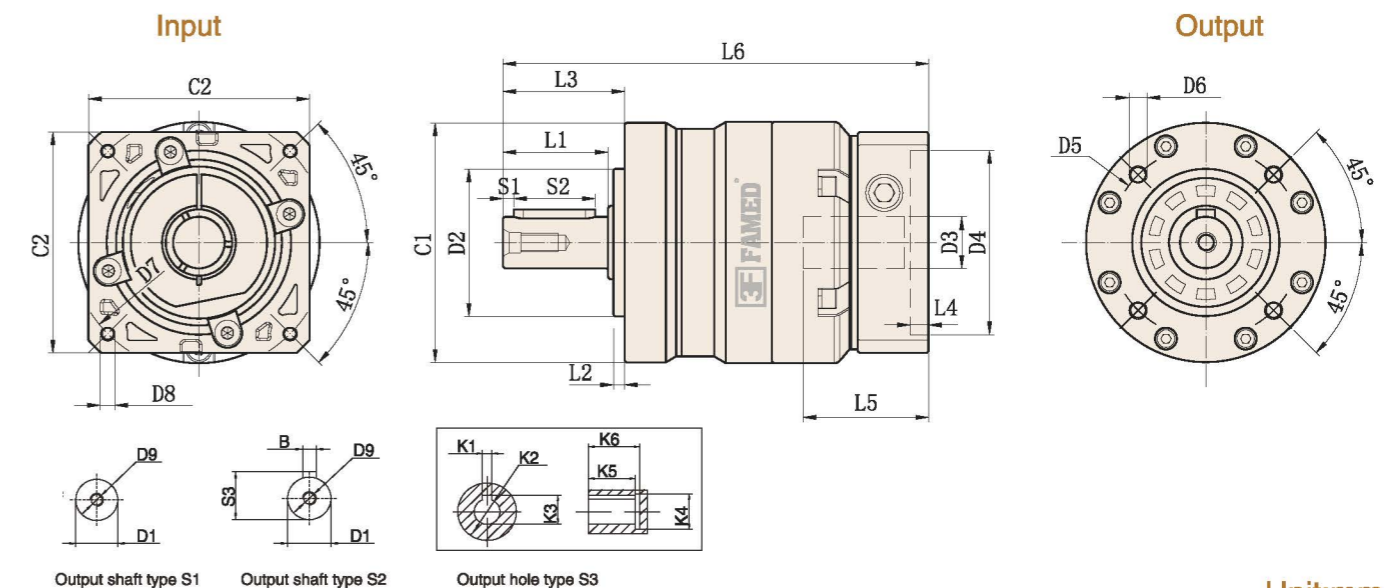

Output shaft type S1

Output shaft type S2

Output hole type S3

Unit:mm

Size	FE040-L1	FE060-L1	FE090-L1	FE120-L1	FE160-L1
D1	φ 12(13)	φ 14(16)	φ 20(22)	φ 25(32)	φ 40
D2	φ 26	φ 40	φ 60	φ 80	φ 130
D3	φ 8(≤11)	φ 14(≤19)	φ 19(≤24)	φ 24(≤32)	φ 35(42)
D4	φ 30(30~50)	φ 50 ( 50~70 )	φ 70 ( 50~70 )	φ 110 ( 70~130 )	φ 114.3(110~150)
D5	φ 34	φ 52	φ 70	φ 100	φ 145
D6	4-M4	4-M5*10	4-M6*12	4-M10*20	4-M12
D7	φ 46(45~70)	φ 70 ( 70~130 )	φ 90 ( 70~130 )	φ 145 ( 90~165 )	φ 200(145~220)
D8	(4-M4X8L)	( 4-M4*10L)	( 4-M5*12L)	( 4-M8*20L)	(4-M12X25L)
D9	M4X0.7P	M5*0.8P*15L	M6*1.0P*16.5L	M10*1.5P*23L	M16X2.0P
L1	18	28.5	36.5	50	80
L2	2	3	3	4	5
L3	26	33	36.5	55	87
L4	( 4 )	(5)	(6.5)	(10)	( 7 )
L5	26	(34)	(42)	(59)	86
L6	88	(115.5)	(147)	(193)	282
C1	φ 42	φ 65	φ 91	φ 120	φ 160
C2	(□50)	( □60 )	( □80 )	( □130 )	(□176)
S1	2	3	4	5	8
S2	14	22	28	40	65
S3	13.5	16	22.5	28	43
B	4	5	6	8	12
K1	-	3	6	8	10
K2	-	φ 8	φ 18	φ 25	φ 35
K3	-	9.2	21	28	38.3
K4	-	φ 11	φ 24	φ 32	φ 42
K5	-	20	30	40	52
K6	-	24	35	48	58

Note 1: Inside of ( ) is the optional range of sizes, outside of ( ) is the standard sizes.

Note 2: The reducer output shaft size and length can be customized for customers.

Note 3: The input size can be changed according to the servomotor or stepper motor of each brand.

# MODEL: FE

2-Stage

Ratio: 12, 15, 16, 20, 25, 28, 30, 35

40, 50, 70, 80, 100



## Dimensions:

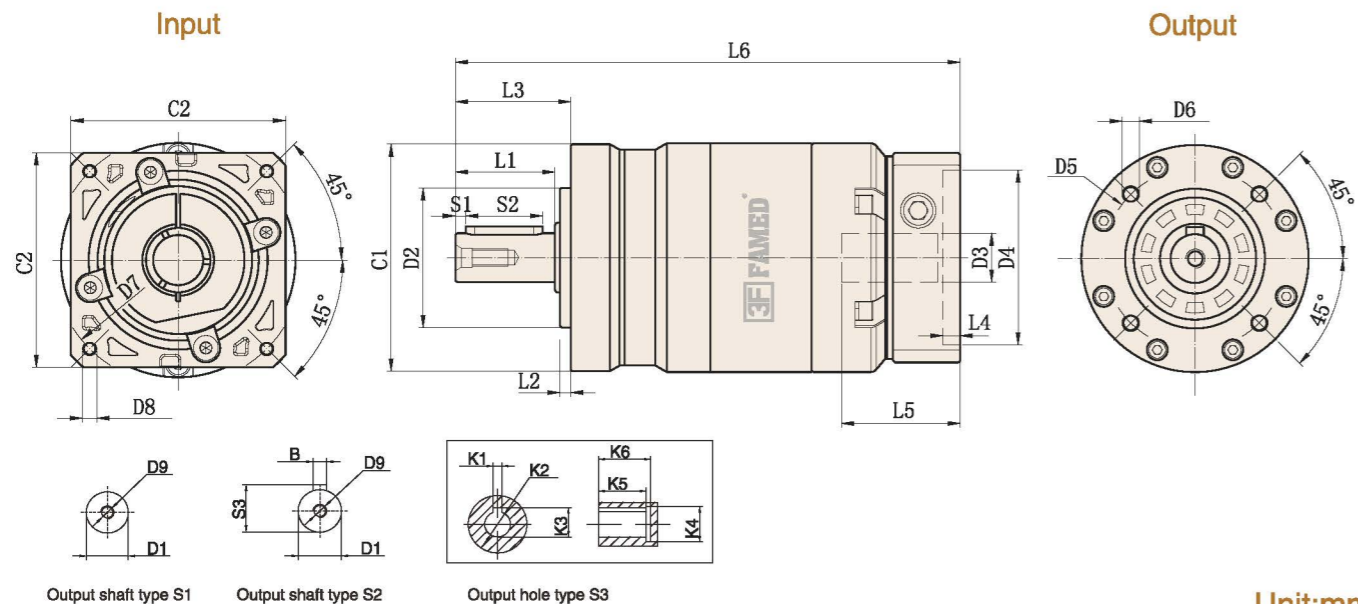

Unit:mm

Size	FE040-L2	FE060-L2	FE090-L2	FE120-L2	FE160-L2
D1	φ 12(13)	φ 14(16)	φ 20(22)	φ 25(32)	φ 40
D2	φ 26	φ 40	φ 60	φ 80	φ 130
D3	φ 8(≤11)	φ 14(≤19)	φ 19(≤24)	φ 24(≤32)	φ 35(42)
D4	φ 30(30-50)	φ 50 ( 50-70 )	φ 70 ( 50-70 )	φ 110 ( 70-130 )	φ 114.3(110-150)
D5	φ 34	φ 52	φ 70	φ 100	φ 145
D6	4-M4	4-M5*10	4-M6*12	4-M10*20	4-M12
D7	φ 46(45-70)	φ 70 ( 70-130 )	φ 90 ( 70-130 )	φ 145 ( 90-165 )	φ 200(145-220)
D8	(4-M4X8L)	( 4-M4*10L)	( 4-M5*12L)	( 4-M8*20L)	(4-M12X25L)
D9	M4X0.7P	M5*0.8P*15L	M6*1.0P*16.5L	M10*1.5P*23L	M16X2.0P
L1	18	28.5	36.5	50	80
L2	2	3	3	4	5
L3	26	33	36.5	55	87
L4	( 4 )	(5)	(6.5)	(10)	( 7 )
L5	26	(34)	(42)	(59)	86
L6	104.5	(144.5)	(177.5)	(232.5)	331.5
C1	φ 42	φ 65	φ 91	φ 120	φ 160
C2	(□50)	( □60 )	( □80 )	( □130 )	(□176)
S1	2	3	4	5	8
S2	14	22	28	40	65
S3	13.5	16	22.5	28	43
B	4	5	6	8	12
K1	-	3	6	8	10
K2	-	φ 8	φ 18	φ 25	φ 35
K3	-	9.2	21	28	38.3
K4	-	φ 11	φ 24	φ 32	φ 42
K5	-	20	30	40	52
K6	-	24	35	48	58

Note 1: Inside of ( ) is the optional range of sizes, outside of ( ) is the standard sizes.

Note 2: The reducer output shaft size and length can be customized for customers.

Note 3: The input size can be changed according to the servomotor or stepper motor of each brand.

# Precision Right Angle Planetary Gearbox

## FER



- 1. Space-saving  
The straight cross reducer uses spiral bevel gear. The installation of the motor can achieve 90 degree bending and save the installation space.
- 2.High rigidity & torque  
The use of integral ball bearings greatly improves the rigidity and torque.
- 3. Connector and shaft sleeve mode  
It can be installed on any motor in the world.
- 4. No grease leakage  
The use of grease with high viscosity which is not easy to separate effectively prevents the grease leakage.
- 5.Convenient maintenance  
No need to replace the grease in the product life period , and the installation is more convenient.

## Model Selection of Speed Reducers

### FER Type

FER090 - 10 - S1 - P1 / Motor

#### Reducer Model

FER040, FER060, FER090  
FER120, FER160

#### Output Shaft Keyway

S1: Solid Output Shaft No Keyway  
S2: Standard (Keyway)  
S3: Output for holes

#### Motor Model

Motor Manufacturer & Model

#### Ratio

1-stage: 3, 4, 5, 6, 7, 8, 9, 10  
2-stage: 12, 15, 16, 20, 25, 28, 30, 35, 40, 50, 70, 80, 100  
3-stage: 60, 64, 72, 80, 90, 100, 120, 144, 150, 160, 180, 200, 240, 258, 288, 320, 384, 512, 600, 800, 1000

#### Backlash Grade

P0: High precision backlash  
P1: Precision backlash  
P2: Standard backlash

The gearbox matching motor needs to be confirmed with following dimensions :

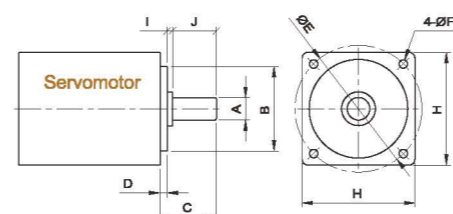

A	B	C	D	E	F	H	I	J

#### Naming Scheme:

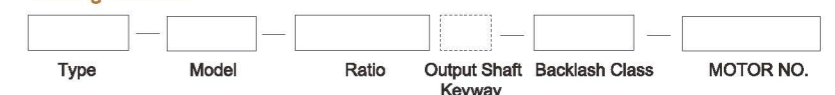

# FER Reducer Specifications

Specs	Unit	Stage	Ratio	FER040	FER060	FER090	FER120	FER160		
Rated Output Torque / T <sub>2N</sub>	Nm	1	3	16	45	125	245	615		
			4	17	50	135	298	650		
			5	18	55	150	300	688		
			7	15	50	145	245	645		
			10	13	45	135	205	498		
		2	15	16	45	120	198	615		
			20	16	50	135	245	650		
			25	18	55	150	300	688		
			30	14	45	125	245	615		
			35	18	55	150	300	688		
					40	13	50	135	298	650
					50	17	55	140	265	688
					70	14	45	130	256	645
					100	13	40	115	205	498
Max. Output Torque / T <sub>2NOT</sub> <sup>1</sup>	Nm	1,2	3~100	3Times of Nominal Output Torque						
Rated Input Speed / n <sub>1N</sub>	rpm	1,2	3~100	3000	3000	3000	3000	2500		
Max. Input Speed / n <sub>1B</sub>	rpm	1,2	3~100	5000	5000	5000	5000	3600		
Precision Backlash P <sub>1</sub>	arcmin	1	3~10	≤8	≤8	≤8	≤8	≤8		
		2	12~100	≤10	≤10	≤10	≤10	≤10		
Standard Backlash P <sub>2</sub>	arcmin	1	3~10	≤11	≤11	≤11	≤11	≤11		
		2	12~100	≤13	≤13	≤13	≤13	≤13		
Torsional Rigidity	Nm/arcmin	1,2	3~100	3	6	12	22	50		
Max. Radial Force / F <sub>2B</sub> <sup>2</sup>	N	1,2	3~100	320	460	1300	3200	6520		
Max. Axial Force / F <sub>2A</sub> <sup>2</sup>	N	1,2	3~100	160	230	660	1600	3260		
Service Life	hr	1,2	3~100	20000 h						
Efficiency / η	%	1	3~10	≥97%						
		2	15~100	≥94%						
Weight	kg	1	3~10	0.73	0.99	2.1	4.98	18.2		
		2	15~100	1.05	1.46	3.2	6.92	24.9		
Operating Temperature	℃	1,2	3~100	-25℃~+90℃						
Lubrication		1,2	3~100	Synthetic Grease						
Protection Class		1,2	3~100	IP65						
Mounting Position		1,2	3~100	Any Direction						
Noise Level (n <sub>1</sub> =3000rpm, No load)	dB(A)	1,2	3~100	≤62	≤63	≤65	≤67	≤68		

## Reducer Rotary Inertia

Specs	Unit	Stage	Ratio	FER040	FER060	FER090	FER120	FER160
Moment of Inertia	kg.cm <sup>2</sup>	1	3	0.03	0.16	0.61	3.25	9.21
			4	0.03	0.14	0.48	2.74	7.54
			5	0.03	0.13	0.47	2.71	7.42
			7	0.03	0.13	0.45	2.65	7.25
			10	0.03	0.13	0.45	2.62	7.14
		2	12~40	0.03	0.13	0.44	2.58	7.07
			50~100	0.03	0.13	0.44	2.57	7.04

- The Max. acceleration torque T<sub>2B</sub>=60% of T<sub>2NOT</sub>
- When output speed is 100rpm, acting on the output shaft center position.
- 3-stage big ratios are not in the above table. There is shaft lengthening and enlarging design. Please tell sales person if you need it.

# MODEL: FER

1-Stage

Ratio: 3, 4, 5, 6, 7, 8, 9, 10



## Dimensions:

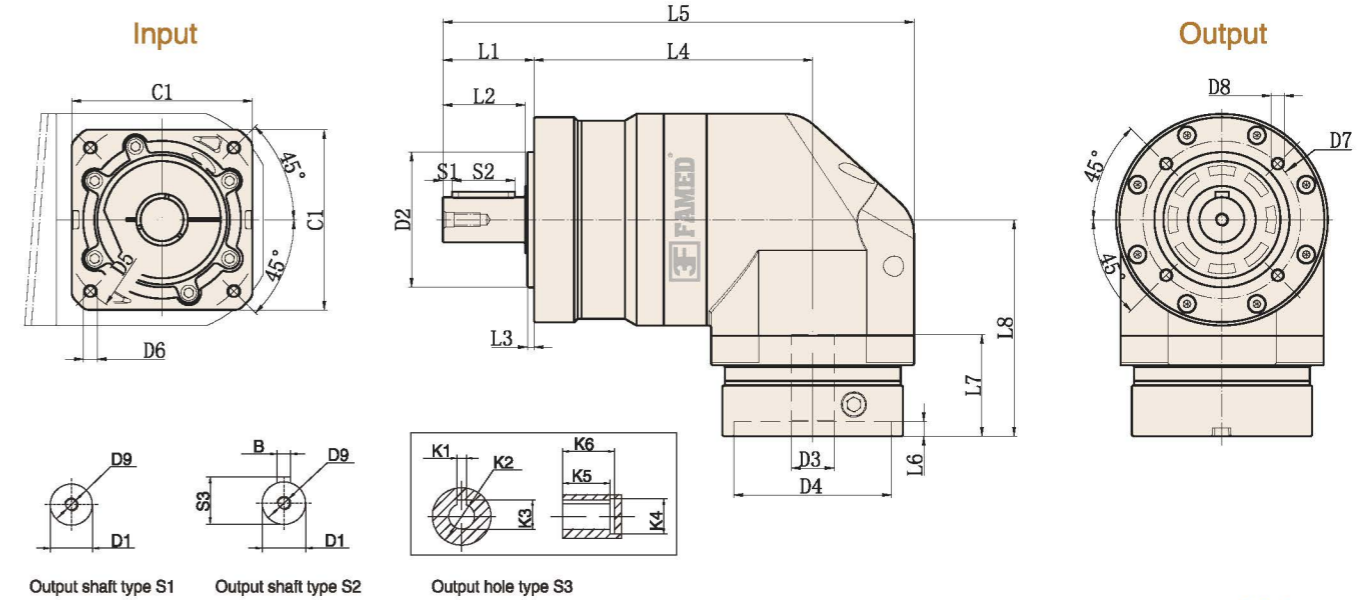

Unit:mm

Size	FER060-L1	FER090-L1	FER120-L1	FER160-L1
D1	φ 14(16)	φ 20(22)	φ 25(32)	φ 40
D2	φ 40	φ 60	φ 80	φ 130
D3	φ 14(6.35~19)	φ 19(11~24)	φ 22(16~24)	φ 35 ( φ 22~38 )
D4	φ 50 ( 30~70 )	φ 70 ( 50~110 )	φ 110 ( 50~110 )	φ 114.3 ( φ 110~114.3 )
D5	φ 70(45~90)	φ 90 ( 70~145 )	φ 145 ( 90~155 )	φ 200 ( φ 145~200 )
D6	( 4-M5*12L)	( 4-M6*14L)	( 4-M8*20L)	4-M12 ( M8-M12 )
D7	φ 52	φ 70	φ 100	φ 145
D8	4-M5*10L	4-M6*12L	4-M8*20L	4-M12X24L
D9	M5*0.8P*15L	M6*1.0P*16.5L	M10*1.5P*23L	M16X2P
L1	33	40.5	55	87
L2	28.5	36.5	50	80
L3	3	3	4	5
L4	90	123.5	146.5	111
L5	153	209	259	295
L6	(5)	6.5	(10)	5 ( 5~7 )
L7	(33)	(45)	(64)	86 ( 62~86 )
L8	(77.5)	(96)	(135.5)	165.5 ( 165.5~189.5 )
C1	( □60 )	( □80 )	( □130 )	175 ( 142 )
S1	3	4	5	5
S2	22	28	40	70
S3	16	22.5	28	43
B	5	6	8	12
K1	4	6	8	10
K2	φ 11	φ 22	φ 28	φ 38
K3	12.8	24.5	31.3	41.3
K4	φ 16	φ 32	φ 38	φ 48
K5	15	20	27	35
K6	18	24	32	40

# MODEL: FER

2-Stage

Ratio: 12, 15, 16, 20, 25, 28, 30, 35  
40, 50, 70, 80, 100



## Dimensions:

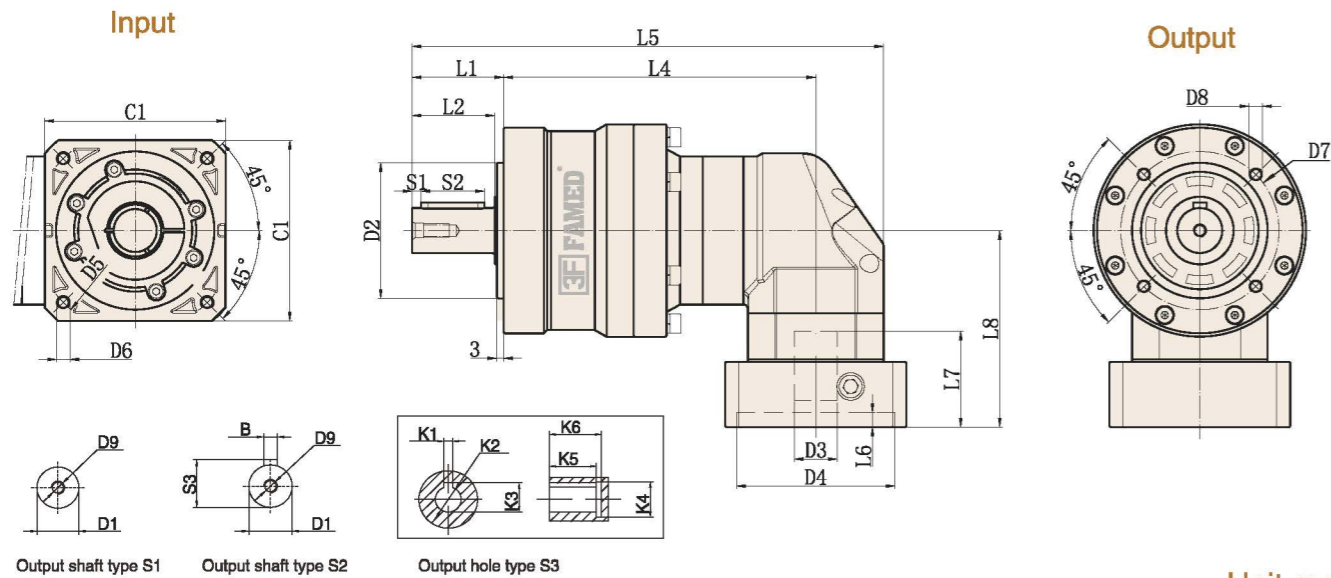

Unit:mm

Size	FER060-L2	FER090-L2	FER120-L2	FER160-L2
D1	φ 14(16)	φ 20(22)	φ 25(32)	φ 40
D2	φ 40	φ 60	φ 80	φ 130
D3	φ 14(6.35-19)	φ 19(11-24)	φ 22(16-24)	φ 35 ( φ 22-38 )
D4	φ 50 ( 30-70 )	φ 70 ( 50-110 )	φ 110 ( 50-110 )	φ 114.3 ( φ 110-114.3 )
D5	φ 70(45-90)	φ 90 ( 70-145 )	φ 145 ( 90-155 )	φ 200 ( φ 145-200 )
D6	( 4-M5*12L)	( 4-M6*14L)	( 4-M8*20L)	4-M12 ( M8-M12 )
D7	φ 52	φ 70	φ 100	φ 145
D8	4-M5*10L	4-M6*12L	4-M8*20L	4-M12X24L
D9	M5*0.8P*15L	M6*1.0P*16.5L	M10*1.5P*23L	M16X2P
L1	33	40.5	55	87
L2	28.5	36.5	50	80
L3	3	3	4	5
L4	119	138	176.5	149
L5	182	208.5	276.5	333
L6	(5)	6.5	(10)	5 ( 5-7 )
L7	(33)	(42.5)	(59)	86 ( 62-86 )
L8	(77.5)	(87)	(120)	165.5 ( 165.5-189.5 )
C1	( □60 )	( □80 )	( □130 )	175 ( 142 )
S1	3	4	5	5
S2	22	28	40	70
S3	16	22.5	28	43
B	5	6	8	12
K1	4	6	8	10
K2	φ 11	φ 22	φ 28	φ 38
K3	12.8	24.5	31.3	41.3
K4	φ 16	φ 32	φ 38	φ 48
K5	15	20	27	35
K6	18	24	32	40

# Standard Type Planetary Gearbox

## PLF



- 1. Quiet operation  
Helical gears are used to achieve smooth and quiet operation.
- 2. High rigidity & torque  
The use of integral ball bearings greatly improves the rigidity and torque.
- 3. Methods of flange and connector  
It can be installed on any motor in the world.
- 4. No grease leakage  
The use of grease with high viscosity which is not easy to separate effectively prevents the grease leakage.
- 5. Convenient maintenance  
No need to replace the grease in the product life period, and the installation is more convenient.

## Model Selection of Speed Reducers

### PLF Type

PLF080 - 10 - S1 - P1 / Motor

<b>Reducer Model</b> PLF040, PLF060, PLF080, PLF090 PLF120, PLF160	<b>Output Shaft Keyway</b> S1: Solid Output Shaft No Keyway S2: Standard (Keyway) S3: Output for holes	<b>Motor Model</b> Motor Manufacturer & Model
<b>Ratio</b> 1-stage: 3, 4, 5, 6, 7, 8, 9, 10 2-stage: 12, 15, 16, 20, 25, 28, 30, 35, 40, 50, 70, 80, 100 3-stage: 60, 64, 72, 80, 90, 100, 120, 144, 150, 160, 180, 200, 240, 258, 288, 320, 384, 512, 600, 800, 1000	<b>Backlash Grade</b> P0: High precision backlash P1: Precision backlash P2: Standard backlash	

The gearbox matching motor needs to be confirmed with following dimensions :

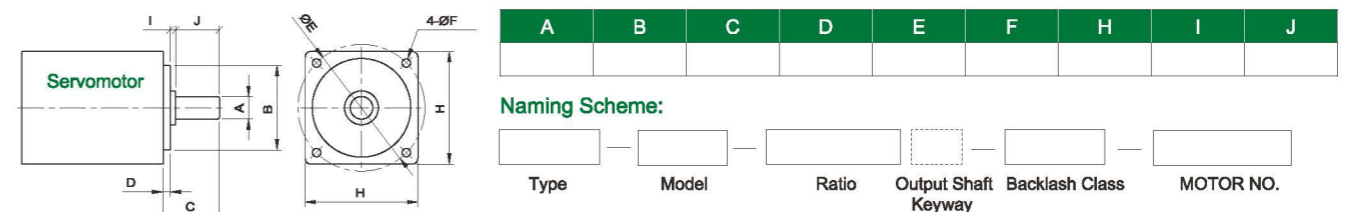

# PLF Reducer Specifications

Specs	Unit	Stage	Ratio	PLF040	PLF060	PLF080	PLF090	PLF120	PLF160
Rated Output Torque / T2N	Nm	1	3	14	28	105	113	150	323
			4	15	38	108	115	160	364
			5	17	40	112	118	160	423
			7	13	35	105	110	149	358
			10	12	25	100	105	141	293
		2	15	14	28	105	113	150	323
			20	15	38	108	120	160	364
			25	17	40	112	118	160	423
			30	13	28	105	113	150	323
			35	17	35	112	118	160	358
			40	12	38	110	115	146	364
			50	15	40	108	118	160	423
		70	13	35	105	110	149	358	
		100	12	25	100	110	141	293	
Max.Output Torque / T2N0.1	Nm	1,2	3~100	3Times of Nominal Output Torque					
Rated Input Speed / Π1N	rpm	1,2	3~100	3000	3000	3000	3000	3000	2500
Max.Input Speed / Π1B	rpm	1,2	3~100	5000	5000	5000	5000	5000	3600
Precision Backlash P1	arcmin	1	3~10	≤6	≤6	≤6	≤6	≤6	≤6
		2	12~100	≤8	≤8	≤8	≤8	≤8	≤8
Standard Backlash P2	arcmin	1	3~10	≤7	≤7	≤7	≤7	≤7	≤7
		2	12~100	≤10	≤10	≤10	≤10	≤10	≤10
Torsional Rigidity	Nm/arcmin	1,2	3~100	3	6	12	12	22	50
Max.Radial Force / F2a2	N	1,2	3~100	320	460	1300	1300	3200	6520
Max.Axial Force / F2a1a2	N	1,2	3~100	160	230	660	660	1600	3260
Service Life	hr	1,2	3~100	20000 h					
Efficiency / η	%	1	3~10	≥97%					
		2	15~100	≥94%					
Weight	kg	1	3~10	0.73	0.99	2.1	2.5	4.98	18.2
		2	15~100	1.05	1.46	3.2	3.5	6.92	24.9
Operating Temperature	℃	1,2	3~100	-25℃~+90℃					
Lubrication		1,2	3~100	Synthetic Grease					
Protection Class		1,2	3~100	IP65					
Mounting Position		1,2	3~100	Any Direction					
Noise Level (n1=3000rpm, No load)	dB(A)	1,2	3~100	≤62	≤63	≤65	≤65	≤67	≤68

# Reducer Rotary Inertia

Specs	Unit	Stage	Ratio	PLF040	PLF060	PLF080	PLF090	PLF120	PLF160
Moment of Inertia	kg.cm <sup>2</sup>	1	3	0.03	0.16	0.61	0.61	3.25	9.21
			4	0.03	0.14	0.48	0.48	2.74	7.54
			5	0.03	0.13	0.47	0.47	2.71	7.42
			7	0.03	0.13	0.45	0.45	2.65	7.25
			10	0.03	0.13	0.45	0.45	2.62	7.14
		2	12~40	0.03	0.13	0.44	0.44	2.58	7.07
			50~100	0.03	0.13	0.44	0.44	2.57	7.04

1. Ratio (i=Nin/Nout) 2. Output revolutions 100rpm, acting on the output shaft center position.  
3. \*Continuous operation, service life is 10000hrs.

# MODEL: PLF

1-Stage

Ratio: 3, 4, 5, 6, 7, 8, 9, 10



## Dimensions:

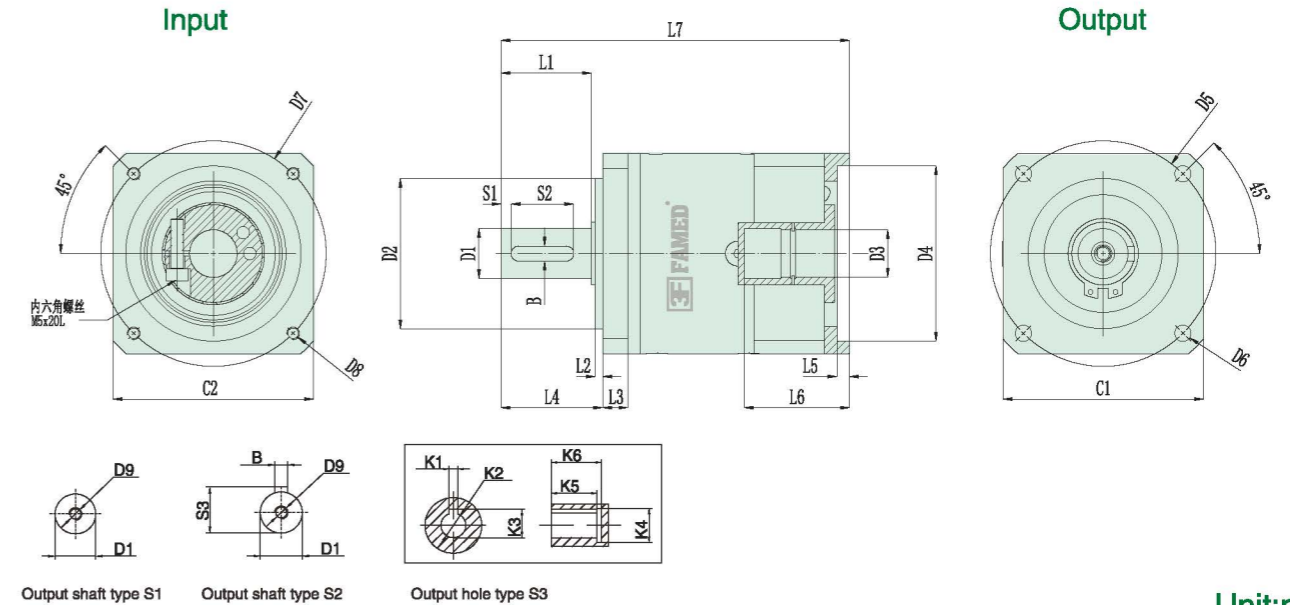

Unit:mm

Size	PLF040-L1	PLF060-L1	PLF080-L1	PLF090-L1	PLF120-L1	PLF160-L1
D1	φ 10	φ 14	φ 20	φ 20	φ 25	φ 40
D2	φ 35	φ 50	φ 80	φ 80	φ 110	φ 130
D3	φ 8 ( ≤8 )	φ 14 ( ≤19 )	φ 19 ( ≤19 )	φ 19 ( ≤22 )	φ 22 ( ≤24 )	φ 35 ( ≤35 )
D4	φ 30 ( 30-50 )	φ 50 ( 50-70 )	φ 70 ( 50-110 )	φ 70 ( 50-110 )	φ 110 ( 70-130 )	φ 114.3 ( 110-150 )
D5	φ 50	φ 70	φ 100	φ 100	φ 130	φ 185
D6	4-φ 3.5	4-φ 5.5	4-φ 6.5	4-φ 6.5	4-φ 8.5	4-φ 11
D7	φ 46 ( 45-70 )	φ 70 ( 70-130 )	φ 90 ( 70-145 )	φ 90 ( 70-145 )	φ 145 ( 90-165 )	φ 200 ( 145-220 )
D8	( 4-M4*12L )	( 4-M4*8L )	( 4-M6*10L )	( 4-M6*10L )	( 4-M8*16L )	( 4-M12*20L )
D9	M3*9L	M5*18L	M6*18L	M6*18L	M10*25L	M16*36L
L1	23	30	36	36	50	80
L2	2	3	3	3	4	5
L3	5	11	10	10	18	20
L4	26	35	40.5	40.5	55.5	87
L5	(3.5)	(4)	(5)	(6)	(10)	(10)
L6	(27)	(31)	(42)	(47)	(62.5)	(81)
L7	(88)	(115)	(139)	(150)	(210)	(276)
C1	□42	□60	□90	□90	□120	□165
C2	( □42 )	( □60 )	( □80 )	( □90 )	( □120 )	( □176 )
S1	2	3	3	3	5	5
S2	16	20	25	25	40	65
S3	11.2	16	22.5	22.5	28	43
B	3	5	6	6	8	12
K1	-	3	5	5	6	10
K2	-	φ 10	φ 15	φ 15	φ 20	φ 35
K3	-	11.4	17.3	17.3	22.8	38.3
K4	-	20	30	30	38	58
K5	-	15	20	20	27	35
K6	-	18	24	24	32	40

Note 1: Inside of ( ) is the optional range of sizes, outside of ( ) is the standard sizes.  
Note 2: The reducer output shaft size and length can be customized for customers.  
Note 3: The input size can be changed according to the servomotor or stepper motor of each brand.

# MODEL: PLF

2-Stage

Ratio: 12, 15, 16, 20, 25, 28, 30, 35  
40, 50, 70, 80, 100



## Dimensions:

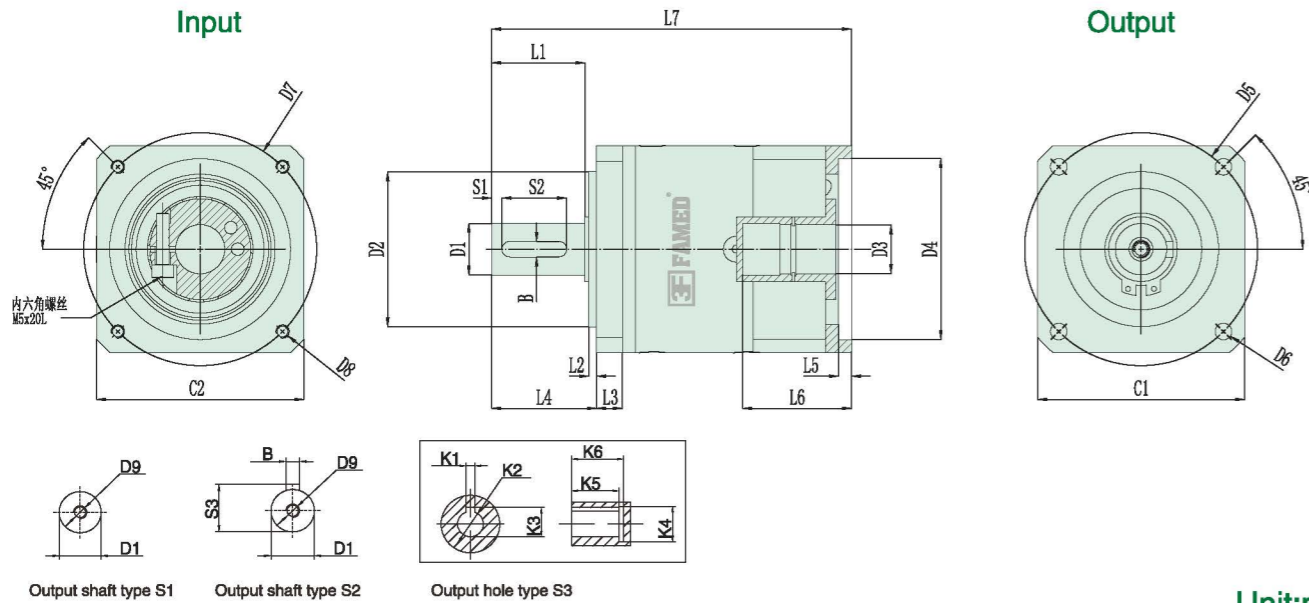

Unit:mm

Size	PLF040-L2	PLF060-L2	PLF080-L2	PLF090-L2	PLF120-L2	PLF160-L2
D1	φ 10	φ 14	φ 20	φ 20	φ 25	φ 40
D2	φ 35	φ 50	φ 80	φ 80	φ 110	φ 130
D3	φ 8 ( ≤8 )	φ 14 ( ≤19 )	φ 19 ( ≤19 )	φ 19 ( ≤22 )	φ 22 ( ≤24 )	φ 35 ( ≤35 )
D4	φ 30 ( 30-50 )	φ 50 ( 50-70 )	φ 70 ( 50-110 )	φ 70 ( 50-110 )	φ 110 ( 70-130 )	φ 114.3 ( 110-150 )
D5	φ 50	φ 70	φ 100	φ 100	φ 130	φ 185
D6	4-φ 3.5	4-φ 5.5	4-φ 6.5	4-φ 6.5	4-φ 8.5	4-φ 11
D7	φ 46 ( 45-70 )	φ 70 ( 70-130 )	φ 90 ( 70-145 )	φ 90 ( 70-145 )	φ 145 ( 90-165 )	φ 200 ( 145-220 )
D8	( 4-M4*12L )	( 4-M4*8L )	( 4-M6*10L )	( 4-M6*10L )	( 4-M8*16L )	( 4-M12*20L )
D9	M3*9L	M5*18L	M6*18L	M6*18L	M10*25L	M16*36L
L1	23	30	36	36	50	80
L2	2	3	3	3	4	5
L3	5	11	10	10	18	20
L4	26	35	40.5	40.5	55.5	87
L5	(3.5)	(4)	(5)	(6)	(10)	(10)
L6	(27)	(31)	(42)	(47)	(62.5)	(81)
L7	(103)	(133)	(159)	(170)	(240)	(317)
C1	□42	□60	□90	□90	□120	□165
C2	( □42 )	( □60 )	( □80 )	( □90 )	( □120 )	( □176 )
S1	2	3	3	3	5	5
S2	16	20	25	25	40	65
S3	11.2	16	22.5	22.5	28	43
B	3	5	6	6	8	12
K1	-	3	5	5	6	10
K2	-	φ 10	φ 15	φ 15	φ 20	φ 35
K3	-	11.4	17.3	17.3	22.8	38.3
K4	-	20	30	30	38	58
K5	-	15	20	20	27	35
K6	-	18	24	24	32	40

Note 1: Inside of ( ) is the optional range of sizes, outside of ( ) is the standard sizes.

Note 2: The reducer output shaft size and length can be customized for customers.

Note 3: The input size can be changed according to the servomotor or stepper motor of each brand.

# Standard Type Right Angle Planetary Gearbox

## PFR



- 1. Space-saving  
The straight cross reducer uses spiral bevel gear. The installation of the motor can achieve 90 degree bending and save the installation space.
- 2. High rigidity & torque  
The use of integral ball bearings greatly improves the rigidity and torque.
- 3. Connector and shaft sleeve mode  
It can be installed on any motor in the world.
- 4. No grease leakage  
The use of grease with high viscosity which is not easy to separate effectively prevents the grease leakage.
- 5. Convenient maintenance  
No need to replace the grease in the product life period, and the installation is more convenient.

## Model Selection of Speed Reducers

### PFR Type

PFR090 - 10 - S1 - P1 / Motor

#### Reducer Model

PFR040, PFR060, PFR090  
PFR120, PFR160

#### Output Shaft Keyway

S1: Solid Output Shaft No Keyway  
S2: Standard (Keyway)  
S3: Output for holes

#### Motor Model

Motor Manufacturer & Model

#### Ratio

1-stage: 3, 4, 5, 6, 7, 8, 9, 10  
2-stage: 12, 15, 16, 20, 25, 28, 30, 35, 40, 50, 70, 80, 100  
3-stage: 60, 64, 72, 80, 90, 100, 120, 144, 150, 160, 180, 200  
240, 258, 288, 320, 384, 512, 600, 800, 1000

#### Backlash Grade

P0: High precision backlash  
P1: Precision backlash  
P2: Standard backlash

The gearbox matching motor needs to be confirmed with following dimensions :

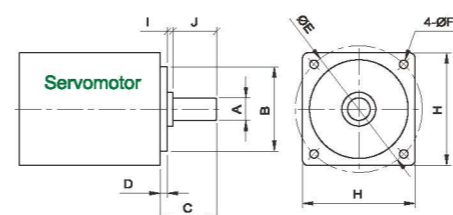

A	B	C	D	E	F	H	I	J

Naming Scheme:

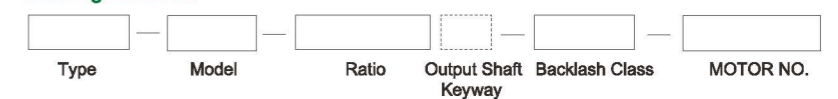

# PFR Reducer Specifications

Specs	Unit	Stage	Ratio	PFR040	PFR060	PFR090	PFR120	PFR160
Rated Output Torque / T2N	Nm	1	3	14	28	113	150	323
			4	15	38	115	160	364
			5	17	40	118	160	423
			7	13	35	110	149	358
			10	12	25	105	141	293
		2	15	14	28	113	150	323
			20	15	38	120	160	364
			25	17	40	118	160	423
			30	13	28	113	150	323
			35	17	35	118	160	358
			40	12	38	115	146	364
			50	15	40	118	160	423
		70	13	35	110	149	358	
		100	12	25	110	141	293	
Max.Output Torque / T2N <sup>1</sup>	Nm	1,2	3~100	3Times of Nominal Output Torque				
Rated Input Speed / n <sub>1N</sub>	rpm	1,2	3~100	3000	3000	3000	3000	2500
Max.Input Speed / n <sub>1B</sub>	rpm	1,2	3~100	5000	5000	5000	5000	3600
Precision Backlash P1	arcmin	1	3~10	≤10	≤10	≤10	≤10	≤10
		2	12~100	≤12	≤12	≤12	≤12	≤12
Standard Backlash P2	arcmin	1	3~10	≤12	≤12	≤12	≤12	≤12
		2	12~100	≤14	≤14	≤14	≤14	≤14
Torsional Rigidity	Nm/arcmin	1,2	3~100	3	6	12	22	50
Max.Radial Force / F <sub>2a</sub> <sup>2</sup>	N	1,2	3~100	320	460	1300	3200	6520
Max.Axial Force / F <sub>2a1B</sub> <sup>2</sup>	N	1,2	3~100	160	230	660	1600	3260
Service Life	hr	1,2	3~100	20000 h				
Efficiency / η	%	1	3~10	≥97%				
		2	15~100	≥94%				
Weight	kg	1	3~10	0.73	0.99	2.1	4.98	18.2
		2	15~100	1.05	1.46	3.2	6.92	24.9
Operating Temperature	°C	1,2	3~100	-25°C~+90°C				
Lubrication		1,2	3~100	Synthetic Grease				
Protection Class		1,2	3~100	IP65				
Mounting Position		1,2	3~100	Any Direction				
Noise Level (n1=3000rpm, No load)	dB(A)	1,2	3~100	≤62	≤63	≤65	≤67	≤68

## Reducer Rotary Inertia

Specs	Unit	Stage	Ratio	PFR040	PFR060	PFR090	PFR120	PFR160
Moment of Inertia	kg.cm <sup>2</sup>	1	3	0.03	0.16	0.61	3.25	9.21
			4	0.03	0.14	0.48	2.74	7.54
			5	0.03	0.13	0.47	2.71	7.42
			7	0.03	0.13	0.45	2.65	7.25
			10	0.03	0.13	0.45	2.62	7.14
		2	12~40	0.03	0.13	0.44	2.58	7.07
			50~100	0.03	0.13	0.44	2.57	7.04

- The Max. acceleration torque T2B=60%
- When output speed is 100rpm, acting on the output shaft center position
- 3-stage big ratios are not in the above table. There is shaft lengthening and enlarging design. Please tell sales person if you need it.

# MODEL: PFR

1-Stage

Ratio: 3, 4, 5, 6, 7, 8, 9, 10



## Dimensions:

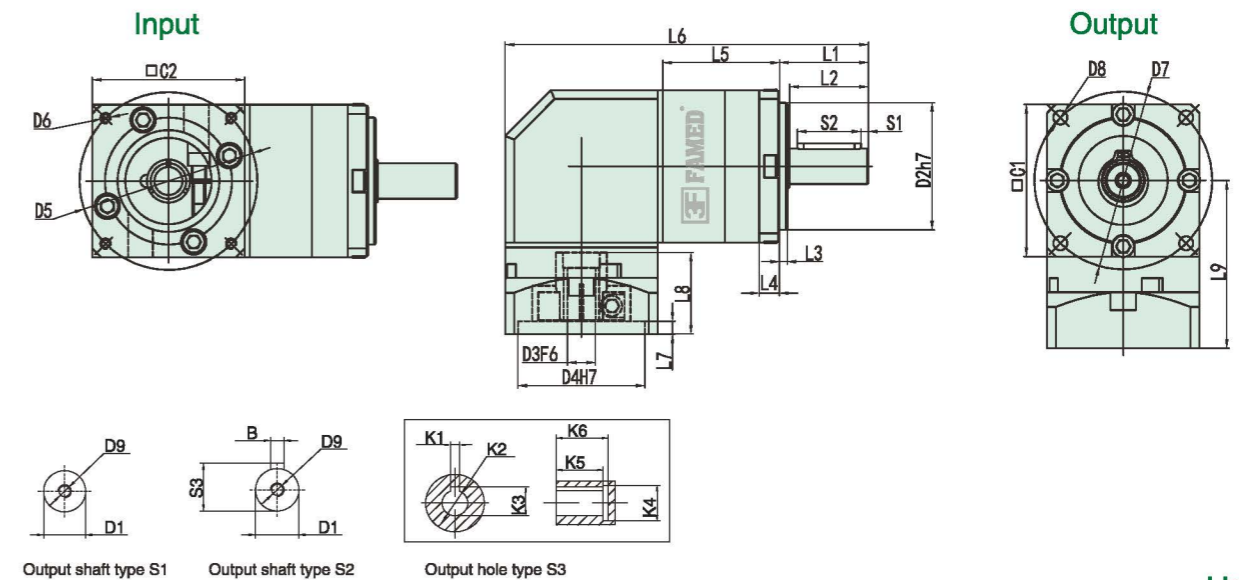

Unit:mm

Size	PFR060-L1	PFR080-L1	PFR120-L1	PFR160-L1
D1	φ 14(16)	φ 20 ( 22 )	φ 25 ( 32 )	φ 40
D2	φ 50	φ 80	φ 110	φ 130
D3	φ 14 ( φ 6.35-19 )	φ 19 ( φ 11-24 )	φ 22 ( φ 16-24 )	φ 35 ( φ 22-38 )
D4	φ 50 ( φ 30-70 )	φ 70 ( φ 50-110 )	φ 110 ( φ 55.5-110 )	φ 114.3 ( φ 110-114.3 )
D5	φ 70 ( φ 45-90 )	φ 90 ( φ 70-145 )	φ 145 ( φ 90-155 )	φ 200 ( φ 145-200 )
D6	4-M4 ( M3-M6 )	4-M5 ( M4-M8 )	4-M8 ( M6-M12 )	4-M12 ( M8-M12 )
D7	φ 70	φ 100	φ 130	φ 185
D8	4-φ 5.5	4-φ 6.5	4-φ 8.5	4-φ 11
D9	M5X0.8P	M8X1.25P	M10X1.5P	M16X2P
L1	35	40	55	87
L2	31	35	49	78
L3	3	3	4	5
L4	8	12	15	20
L5	46	55	80	111
L6	143	190	273	295
L7	5(4-6)	8(5-8)	8(5-8)	5 ( 5-7 )
L8	32(32-44)	42(42-60)	70 ( 59-70 )	86 ( 62-86 )
L9	66(66-88)	95.5(95.5-113.5)	130 ( 119-130 )	165.5 ( 165.5-189.5 )
C1	60	90	120	160
C2	60(60-90)	90(90-130)	130 ( 120 )	175 ( 142 )
S1	3	3	5	5
S2	25	30	40	70
S3	16	22.5	28	43
B	5	6	8	12
K1	4	6	8	10
K2	φ 11	φ 22	φ 28	φ 38
K3	12.8	24.5	31.3	41.3
K4	φ 16	φ 32	φ 38	φ 48
K5	15	20	27	35
K6	18	24	32	40

# MODEL: PFR

2-Stage

Ratio: 12, 15, 16, 20, 25, 28, 30, 35  
40, 50, 70, 80, 100



## Dimensions:

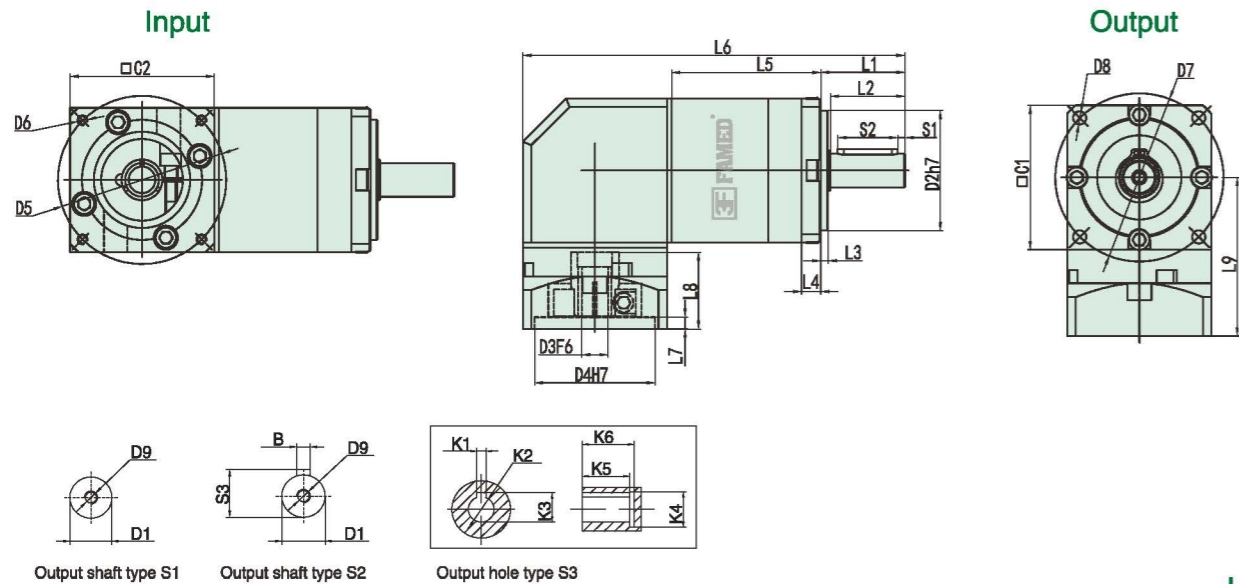

Unit:mm

Size	PFR060-L2	PFR080-L2	PFR120-L2	PFR160-L2
D1	φ 14(16)	φ 20 ( 22 )	φ 25 ( 32 )	φ 40
D2	φ 50	φ 80	φ 110	φ 130
D3	φ 14 ( φ 6.35-19 )	φ 19 ( φ 11-24 )	φ 22 ( φ 16-24 )	φ 35 ( φ 22-38 )
D4	φ 50 ( φ 30-70 )	φ 70 ( φ 50-110 )	φ 110 ( φ 55.5-110 )	φ 114.3 ( φ 110-114.3 )
D5	φ 70 ( φ 45-90 )	φ 90 ( φ 70-145 )	φ 145 ( φ 90-155 )	φ 200 ( φ 145-200 )
D6	4-M4 ( M3-M6 )	4-M5 ( M4-M8 )	4-M8 ( M6-M12 )	4-M12 ( M8-M12 )
D7	φ 70	φ 100	φ 130	φ 185
D8	4-φ 5.5	4-φ 6.5	4-φ 8.5	4-φ 11
D9	M5X0.8P	M8X1.25P	M10X1.5P	M16X2P
L1	35	40	55	87
L2	31	35	49	78
L3	3	3	4	5
L4	8	12	15	20
L5	62	78.5	110	149
L6	159	213.5	303	333
L7	5(4-6)	8(5-8)	8(5-8)	5 ( 5-7 )
L8	32(32-44)	42(42-60)	70 ( 59-70 )	86 ( 62-86 )
L9	66(66-88)	95.5(95.5-113.5)	130 ( 119-130 )	165.5 ( 165.5-189.5 )
C1	60	90	120	160
C2	60(60-90)	90(90-130)	130 ( 120 )	175 ( 142 )
S1	3	3	5	5
S2	25	30	40	70
S3	16	22.5	28	43
B	5	6	8	12
K1	4	6	8	10
K2	φ 11	φ 22	φ 28	φ 38
K3	12.8	24.5	31.3	41.3
K4	φ 16	φ 32	φ 38	φ 48
K5	15	20	27	35
K6	18	24	32	40

# Standard Type Planetary Gearbox

## PLE



- 1. Quiet operation  
Helical gears are used to achieve smooth and quiet operation.
- 2. High rigidity & torque  
The use of integral ball bearings greatly improves the rigidity and torque.
- 3. Methods of flange and connector  
It can be installed on any motor in the world.
- 4. No grease leakage  
The use of grease with high viscosity which is not easy to separate effectively prevents the grease leakage.
- 5. Convenient maintenance  
No need to replace the grease in the product life period, and the installation is more convenient.

## Model Selection of Speed Reducers

**PLE Type**

PLE080 - 10 - S1 - P1 / Motor

**Reducer Model**

PLE040, PLE060, PLE080, PLE090  
PLE120, PLE160

**Output Shaft Keyway**

S1: Solid Output Shaft No Keyway  
S2: Standard (Keyway)  
S3: Output for holes

**Motor Model**

Motor Manufacturer & Model

**Ratio**

1-stage: 3, 4, 5, 6, 7, 8, 9, 10  
2-stage: 12, 15, 16, 20, 25, 28, 30, 35, 40, 50, 70, 80, 100  
3-stage: 60, 64, 72, 80, 90, 100, 120, 144, 150, 160, 180, 200  
240, 258, 288, 320, 384, 512, 600, 800, 1000

**Backlash Grade**

P0: High precision backlash  
P1: Precision backlash  
P2: Standard backlash

The gearbox matching motor needs to be confirmed with following dimensions :

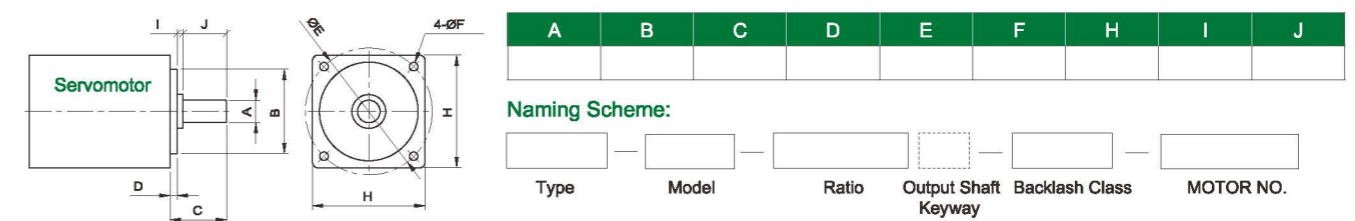

## PLE Reducer Specifications

Specs	Unit	Stage	Ratio	PLE040	PLE060	PLE080	PLE090	PLE120	PLE160
Rated Output Torque / T <sub>2N</sub>	Nm	1	3	14	28	105	113	150	323
			4	15	38	108	115	160	364
			5	17	40	112	118	160	423
			7	15	35	105	110	149	358
			10	12	25	100	105	141	293
		2	15	14	28	105	113	150	323
			20	15	38	108	120	160	364
			25	17	40	112	118	160	423
			30	13	28	105	113	150	323
			35	17	35	112	118	160	358
			40	12	38	110	115	146	364
			50	15	40	108	118	160	423
		70	13	35	105	110	149	358	
			100	12	25	100	110	141	293
Max.Output Torque / T <sub>200r1</sub>	Nm	1,2	3~100	3Times of Nominal Output Torque					
Rated Input Speed / Π <sub>IN</sub>	rpm	1,2	3~100	3000	3000	3000	3000	3000	2500
Max.Input Speed / Π <sub>is</sub>	rpm	1,2	3~100	5000	5000	5000	5000	5000	3600
Precision Backlash P1	arcmin	1	3~10	≤6	≤6	≤6	≤6	≤6	≤6
		2	12~100	≤8	≤8	≤8	≤8	≤8	≤8
Standard Backlash P2	arcmin	1	3~10	≤8	≤8	≤8	≤8	≤8	≤8
		2	12~100	≤10	≤10	≤10	≤10	≤10	≤10
Torsional Rigidity	Nm/arcmin	1,2	3~100	3	6	12	12	22	50
Max.Radial Force / F <sub>2a</sub> ²	N	1,2	3~100	320	460	1300	1300	3200	6520
Max.Axial Force / F <sub>2a1</sub> ²	N	1,2	3~100	160	230	660	660	1600	3260
Service Life	hr	1,2	3~100	20000 h					
Efficiency / η	%	1	3~10	≥97%					
		2	15~100	≥94%					
Weight	kg	1	3~10	0.73	0.99	2.1	2.4	4.98	18.2
		2	15~100	1.05	1.46	3.2	3.6	6.92	24.9
Operating Temperature	℃	1,2	3~100	-25℃~+90℃					
Lubrication		1,2	3~100	Synthetic Grease					
Protection Class		1,2	3~100	IP65					
Mounting Position		1,2	3~100	Any Direction					
Noise Level (n1=3000rpm, No load)	dB(A)	1,2	3~100	≤62	≤63	≤65	≤65	≤67	≤68

## Reducer Rotary Inertia

Specs	Unit	Stage	Ratio	PLE040	PLE060	PLE080	PLE090	PLE120	PLE160
Moment of Inertia	kg.cm <sup>2</sup>	1	3	0.03	0.16	0.61	0.61	3.25	9.21
			4	0.03	0.14	0.48	0.48	2.74	7.54
			5	0.03	0.13	0.47	0.47	2.71	7.42
			7	0.03	0.13	0.45	0.45	2.65	7.25
			10	0.03	0.13	0.45	0.45	2.62	7.14
		2	12~40	0.03	0.13	0.44	0.44	2.58	7.07
			50~100	0.03	0.13	0.44	0.44	2.57	7.04

- Ratio (i=Nin/Nout)
- Output revolutions 100rpm, acting on the output shaft center position.
- \*Continuous operation, service life is 10000hrs.

# MODEL: PLE

1-Stage

Ratio: 3, 4, 5, 6, 7, 8, 9, 10



## Dimensions:

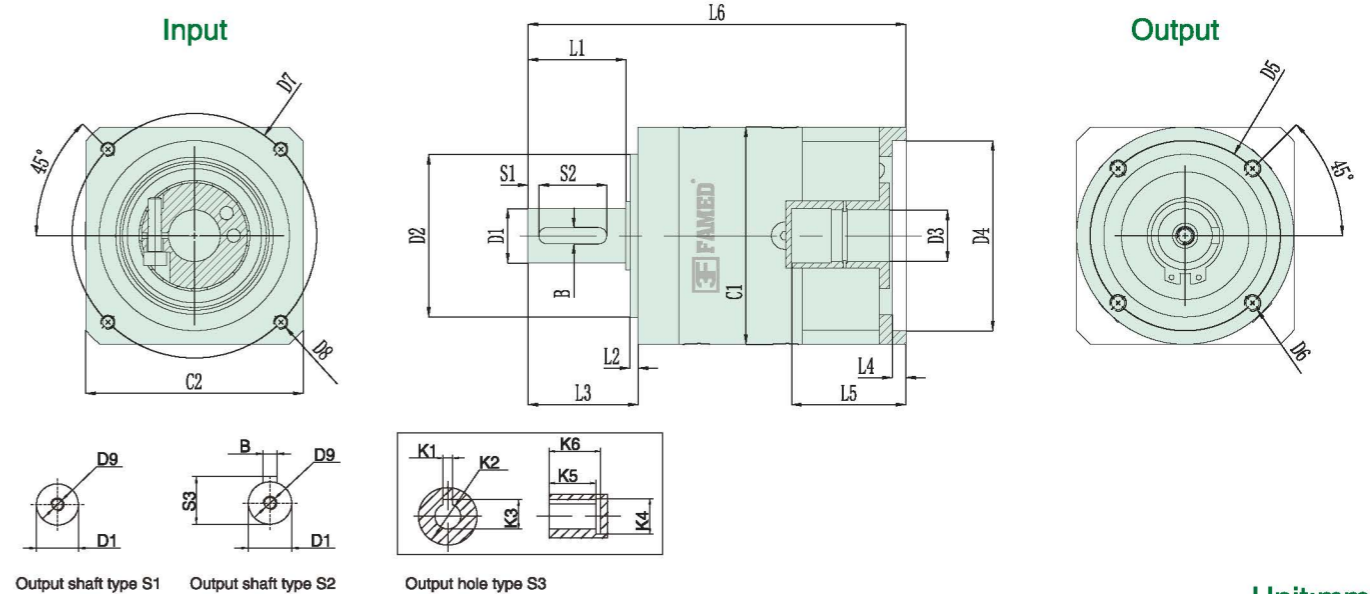

Unit:mm

Size	PLE040-L1	PLE060-L1	PLE080-L1	PLE090-L1	PLE120-L1	PLE160-L1
D1	φ 10	φ 14	φ 20	φ 20	φ 25	φ 40
D2	φ 26	φ 40	φ 60	φ 60	φ 80	φ 130
D3	φ 8 ( ≤8 )	φ 14 ( ≤14 )	φ 19 ( ≤19 )	φ 19 ( ≤24 )	φ 22 ( ≤24 )	φ 35 ( ≤35 )
D4	φ 30 ( 30-50 )	φ 50 ( 50-70 )	φ 70 ( 50-110 )	φ 70 ( 50-110 )	φ 110 ( 70-130 )	φ 114.3 ( 110-150 )
D5	φ 34	φ 52	φ 70	φ 70	φ 100	φ 145
D6	(4-M4*8L)	(4-M5*15L)	(4-M6*12L)	(4-M6*20L)	(4-M10*18L)	(4-M12*24L)
D7	φ 46 ( 45-70 )	φ 70 ( 70-130 )	φ 90 ( 70-145 )	φ 90 ( 70-145 )	φ 145 ( 90-165 )	φ 200 ( 145-220 )
D8	( 4-M4*12L )	( 4-M5*10L )	( 4-M6*15L )	( 4-M6*15L )	( 4-M8*16L )	( 4-M12*20L )
D9	M3*9L	M5*16L	M6*18L	M6*18L	M10*25L	M16*30L
L1	23	30	36	36	50	80
L2	2	3	3	3	4	5
L3	26	35	40.5	40.5	55.5	87
L4	(3.5)	(4)	(5)	(6)	(10)	(10)
L5	(27)	(31)	(42)	(47)	(62.5)	(81)
L6	(88)	(115)	(139.0)	(150)	(210)	(276)
C1	φ 42	φ 60	φ 80		φ 120	φ 165
C2	( □42 )	( □60 )	( □80 )	( □90 )	( □120 )	( □176 )
S1	2	3	4	3	5	5
S2	16	20	25	25	40	65
S3	11.2	16	22.5	22.5	28	43
B	3	5	6	6	8	12
K1	-	3	5	5	6	10
K2	-	φ 10	φ 15	φ 15	φ 20	φ 35
K3	-	11.4	17.3	17.3	22.8	38.3
K4	-	20	30	30	38	58
K5	-	15	20	20	27	35
K6	-	18	24	24	32	40

Note 1: Inside of ( ) is the optional range of sizes, outside of ( ) is the standard sizes.

Note 2: The reducer output shaft size and length can be customized for customers.

Note 3: The input size can be changed according to the servomotor or stepper motor of each brand.

# MODEL: PLE

2-Stage

Ratio: 12, 15, 16, 20, 25, 28, 30, 35  
40, 50, 70, 80, 100



## Dimensions:

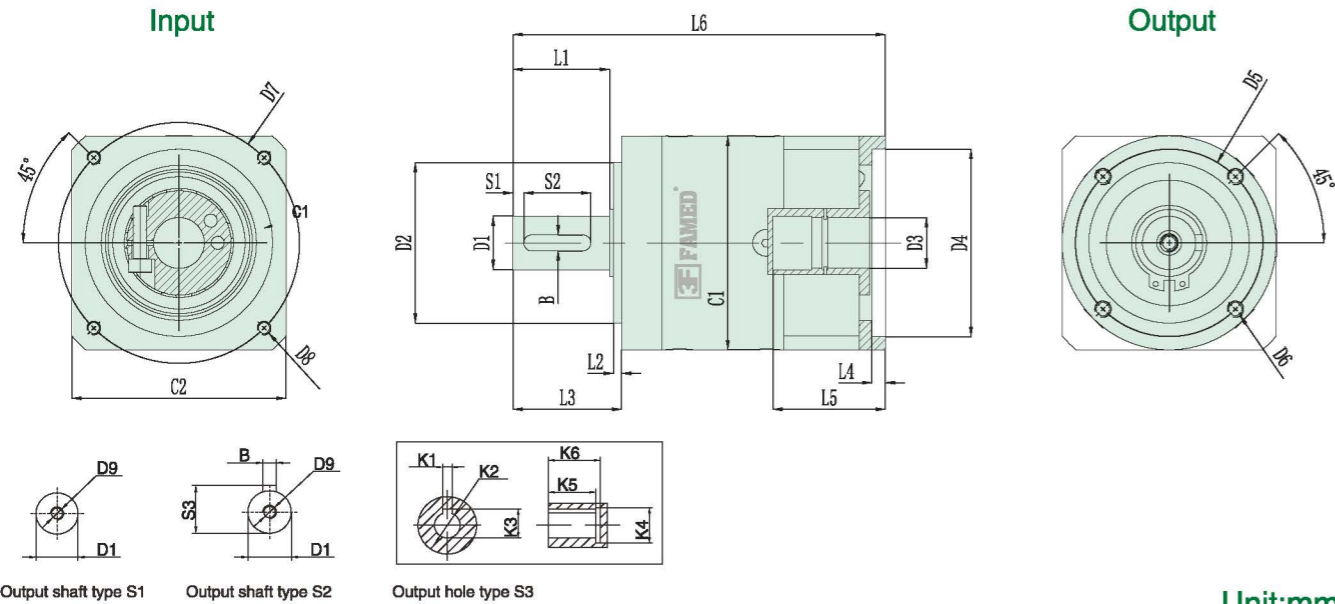

Unit:mm

Size	PLE040-L2	PLE060-L2	PLE080-L2	PLE090-L2	PLE120-L2	PLE160-L2
D1	φ 10	φ 14	φ 20	φ 20	φ 25	φ 40
D2	φ 26	φ 40	φ 60	φ 60	φ 80	φ 130
D3	φ 8 ( ≤8 )	φ 14 ( ≤14 )	φ 19 ( ≤19 )	φ 19 ( ≤24 )	φ 22 ( ≤24 )	φ 35 ( ≤35 )
D4	φ 30 ( 30-50 )	φ 50 ( 50-70 )	φ 70 ( 50-110 )	φ 70 ( 50-110 )	φ 110 ( 70-130 )	φ 114.3 ( 110-150 )
D5	φ 34	φ 52	φ 70	φ 70	φ 100	φ 145
D6	(4-M4*8L)	(4-M5*15L)	(4-M6*12L)	(4-M6*20L)	(4-M10*18L)	(4-M12*24L)
D7	φ 46 ( 45-70 )	φ 70 ( 70-130 )	φ 90 ( 70-145 )	φ 90 ( 70-145 )	φ 145 ( 90-165 )	φ 200 ( 145-220 )
D8	( 4-M4*12L )	( 4-M5*10L )	( 4-M6*15L )	( 4-M6*15L )	( 4-M8*16L )	( 4-M12*20L )
D9	M3*9L	M5*16L	M6*18L	M6*18L	M10*25L	M16*30L
L1	23	30	36	36	50	80
L2	2	3	3	3	4	5
L3	26	35	40.5	40.5	55.5	87
L4	(3.5)	(4)	(5)	(6)	(10)	(10)
L5	(27)	(31)	(42)	(47)	(62.5)	(81)
L6	(103)	(133)	(159.0)	(170)	(239.5)	(317)
C1	φ 42	φ 60	φ 80		φ 120	φ 165
C2	( □42 )	( □60 )	( □80 )	( □90 )	( □120 )	( □176 )
S1	2	3	4	3	5	5
S2	16	20	25	25	40	65
S3	11.2	16	22.5	22.5	28	43
B	3	5	6	6	8	12
K1	-	3	5	5	6	10
K2	-	φ 10	φ 15	φ 15	φ 20	φ 35
K3	-	11.4	17.3	17.3	22.8	38.3
K4	-	20	30	30	38	58
K5	-	15	20	20	27	35
K6	-	18	24	24	32	40

Note 1: Inside of ( ) is the optional range of sizes, outside of ( ) is the standard sizes.

Note 2: The reducer output shaft size and length can be customized for customers.

Note 3: The input size can be changed according to the servomotor or stepper motor of each brand.

# Standard Type Right Angle Planetary Gearbox

## PER



- 1. Space-saving  
The straight cross reducer uses spiral bevel gear. The installation of the motor can achieve 90 degree bending and save the installation space.
- 2. High rigidity & torque  
The use of integral ball bearings greatly improves the rigidity and torque.
- 3. Connector and shaft sleeve mode  
It can be installed on any motor in the world.
- 4. No grease leakage  
The use of grease with high viscosity which is not easy to separate effectively prevents the grease leakage.
- 5. Convenient maintenance  
No need to replace the grease in the product life period, and the installation is more convenient.

## Model Selection of Speed Reducers

### PER Type

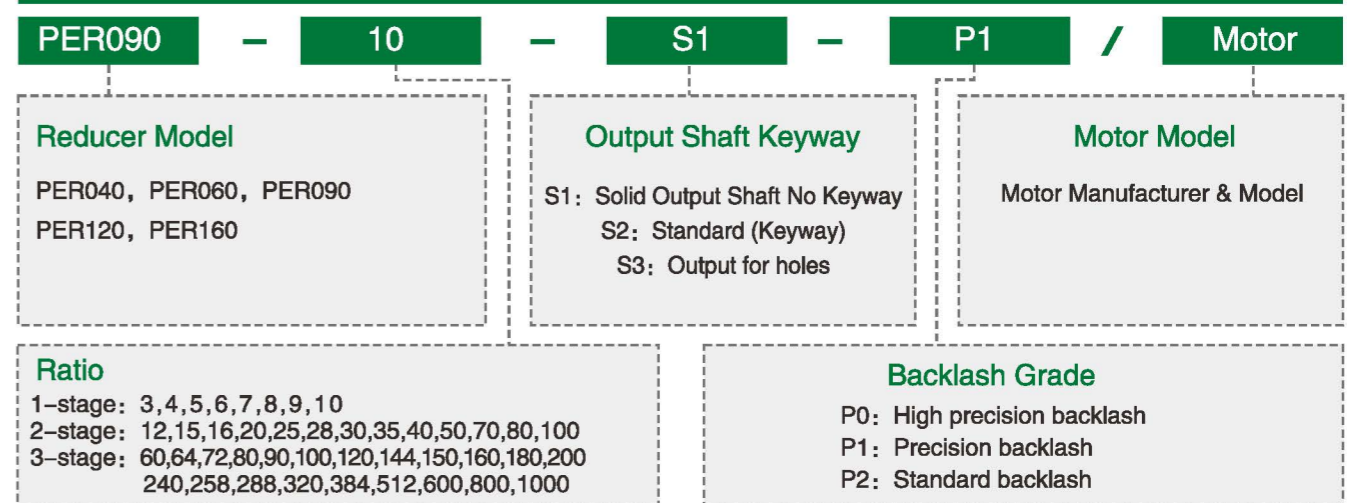

The gearbox matching motor needs to be confirmed with following dimensions :

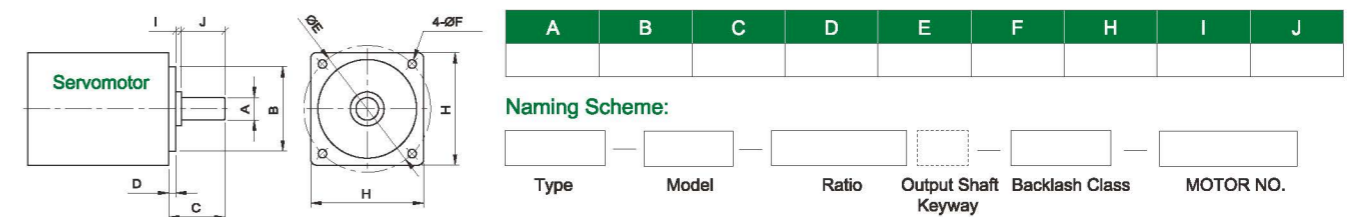

## PER Reducer Specifications

Specs	Unit	Stage	Ratio	PER040	PER060	PER090	PER120	PER160
Rated Output Torque / T <sub>2N</sub>	Nm	1	3	14	28	113	150	323
			4	15	38	115	160	364
			5	17	40	118	160	423
			7	13	35	110	149	358
			10	12	25	105	141	293
		2	15	14	28	113	150	323
			20	15	38	120	160	364
			25	17	40	118	160	423
			30	13	28	113	150	323
			35	17	35	118	160	358
			40	12	38	115	146	364
			50	15	40	118	160	423
			70	13	35	110	149	358
			100	12	25	110	141	293
Max. Output Torque / T <sub>2NOT</sub> <sup>1</sup>	Nm	1,2	3~100	3Times of Nominal Output Torque				
Rated Input Speed / Π <sub>IN</sub>	rpm	1,2	3~100	3000	3000	3000	3000	2500
Max. Input Speed / Π <sub>IS</sub>	rpm	1,2	3~100	5000	5000	5000	5000	3600
Precision Backlash P1	arcmin	1	3~10	≤10	≤10	≤10	≤10	≤10
		2	12~100	≤12	≤12	≤12	≤12	≤12
Standard Backlash P2	arcmin	1	3~10	≤12	≤12	≤12	≤12	≤12
		2	12~100	≤14	≤14	≤14	≤14	≤14
Torsional Rigidity	Nm/arcmin	1,2	3~100	3	6	12	22	50
Max. Radial Force / F <sub>2B</sub> <sup>2</sup>	N	1,2	3~100	320	460	1300	3200	6520
Max. Axial Force / F <sub>2A</sub> <sup>2</sup>	N	1,2	3~100	160	230	660	1600	3260
Service Life	hr	1,2	3~100	20000 h				
Efficiency / η	%	1	3~10	≥97%				
		2	15~100	≥94%				
Weight	kg	1	3~10	0.73	0.99	2.1	4.98	18.2
		2	15~100	1.05	1.46	3.2	6.92	24.9
Operating Temperature	°C	1,2	3~100	-25°C~+90°C				
Lubrication		1,2	3~100	Synthetic Grease				
Protection Class		1,2	3~100	IP65				
Mounting Position		1,2	3~100	Any Direction				
Noise Level (n1=3000rpm, No load)	dB(A)	1,2	3~100	≤62	≤63	≤65	≤67	≤68

## Reducer Rotary Inertia

Specs	Unit	Stage	Ratio	PER040	PER060	PER090	PER120	PER160
Moment of Inertia	kg.cm <sup>2</sup>	1	3	0.03	0.16	0.61	3.25	9.21
			4	0.03	0.14	0.48	2.74	7.54
			5	0.03	0.13	0.47	2.71	7.42
			7	0.03	0.13	0.45	2.65	7.25
			10	0.03	0.13	0.45	2.62	7.14
		2	12~40	0.03	0.13	0.44	2.58	7.07
			50~100	0.03	0.13	0.44	2.57	7.04

1. The Max. acceleration torque T<sub>2B</sub>=60% of T<sub>2NOT</sub> 2. When output speed is 100rpm, acting on the output shaft center position.  
3. 3-stage big ratios are not in the above table. There is shaft lengthening and enlarging design. Please tell sales person if you need it.

# MODEL: PER

1-Stage

Ratio: 3, 4, 5, 6, 7, 8, 9, 10



## Dimensions:

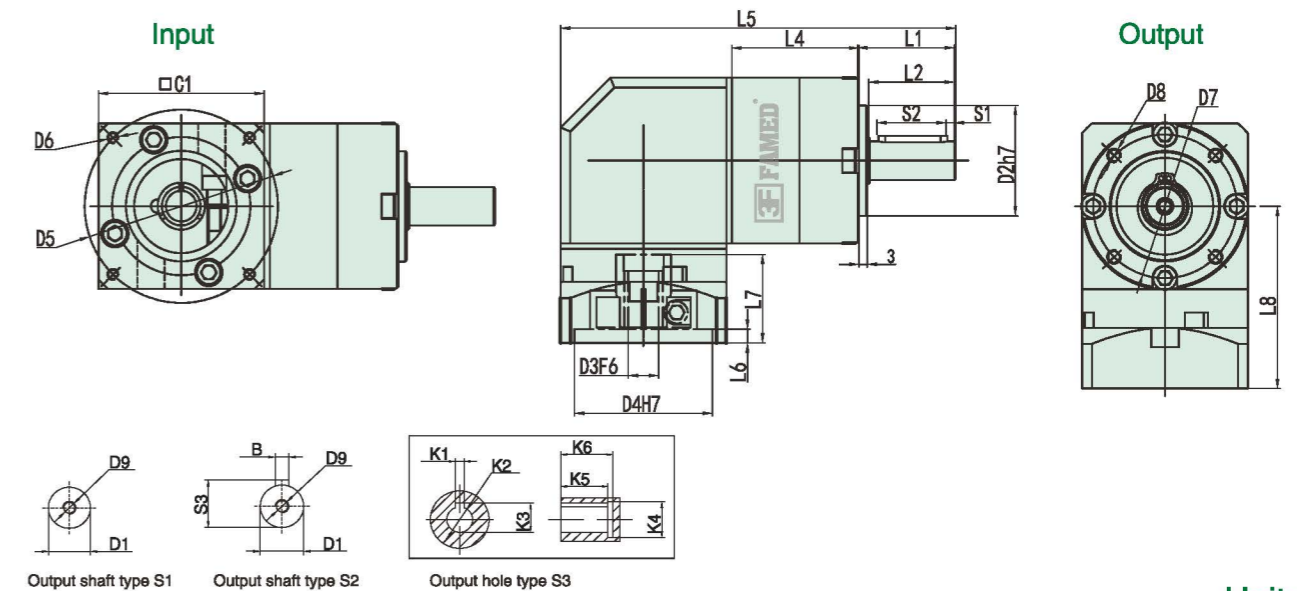

Unit:mm

Size	PER060-L1	PER090-L1	PER120-L1	PER160-L1
D1	φ 14 (16)	φ 20 (22)	φ 25 (32)	φ 40
D2	φ 40	φ 60	φ 80	φ 130
D3	φ 14 ( φ 6.35-19 )	φ 19 ( φ 11-24 )	φ 22 ( φ 16-24 )	φ 35 ( φ 22-38 )
D4	φ 50 ( φ 30-70 )	φ 70 ( φ 50-110 )	φ 110 ( φ 55.5-110 )	φ 114.3 ( φ 110-114.3 )
D5	φ 70 ( φ 45-90 )	φ 90 ( φ 70-145 )	φ 145 ( φ 90-155 )	φ 200 ( φ 145-200 )
D6	4-M4 ( M3-M6 )	4-M5 ( M4-M8 )	4-M8 ( M6-M12 )	4-M12 ( M8-M12 )
D7	φ 52	φ 70	φ 100	φ 145
D8	4-M5X10L	4-M6X12L	4-M10X20L	4-M12X24L
D9	M5X0.8P	M8X1.25P	M10X1.5P	M16X2P
L1	35	40	55	87
L2	31	35	49	80
L3	3	3	4	5
L4	46	55	80	111
L5	143	190	273	295
L6	5(4-6)	8(5-8)	8(5-8)	5 ( 5-7 )
L7	32(32-44)	42(42-60)	70 ( 59-70 )	86 ( 62-86 )
L8	66(66-88)	95.5(95.5-113.5)	130 ( 119-130 )	165.5 ( 165.5-189.5 )
C1	60(60-90)	90(90-130)	130 ( 120 )	175 ( 142 )
S1	3	3	5	5
S2	25	30	40	70
S3	16	22.5	28	43
B	5	6	8	12
K1	4	6	8	10
K2	φ 11	φ 22	φ 28	φ 38
K3	12.8	24.5	31.3	41.3
K4	φ 16	φ 32	φ 38	φ 48
K5	15	20	27	35
K6	18	24	32	40

# MODEL: PER

2-Stage

Ratio: 12, 15, 16, 20, 25, 28, 30, 35  
40, 50, 70, 80, 100



## Dimensions:

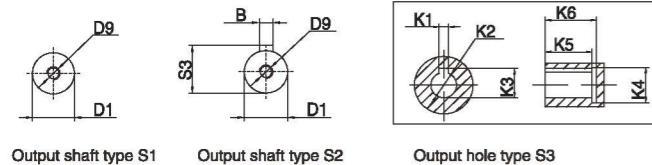
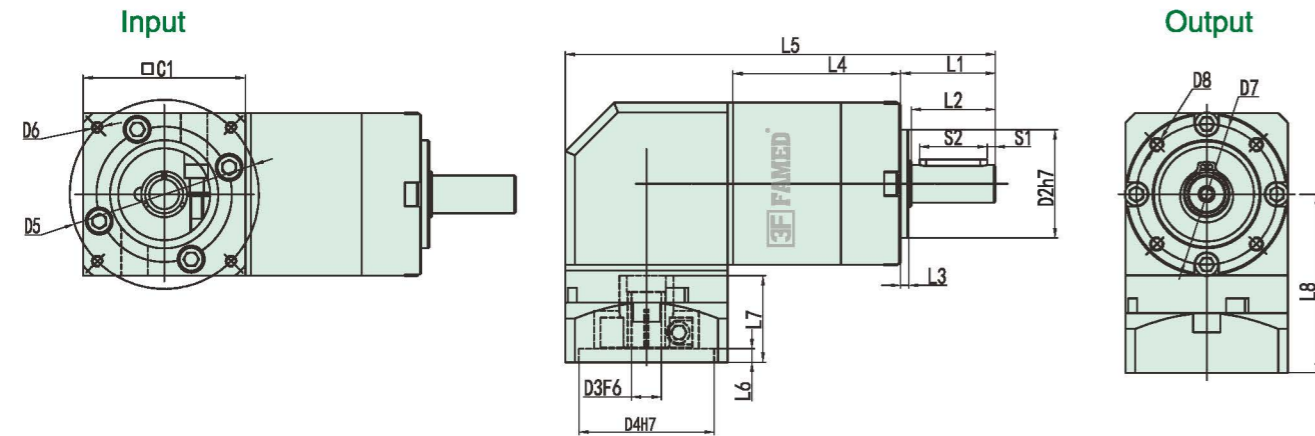

Output shaft type S1    Output shaft type S2    Output hole type S3

Unit:mm

Size	PER060-L2	PER090-L2	PER120-L2	PER160-L2
D1	φ 14(16)	φ 20 ( 22 )	φ 25 ( 32 )	φ 40
D2	φ 40	φ 60	φ 80	φ 130
D3	φ 14 ( φ 6.35-19 )	φ 19 ( φ 11-24 )	φ 22 ( φ 16-24 )	φ 35 ( φ 22-38 )
D4	φ 50 ( φ 30-70 )	φ 70 ( φ 50-110 )	φ 110 ( φ 55.5-110 )	φ 114.3 ( φ 110-114.3 )
D5	φ 70 ( φ 45-90 )	φ 90 ( φ 70-145 )	φ 145 ( φ 90-155 )	φ 200 ( φ 145-200 )
D6	4-M4 ( M3-M6 )	4-M5 ( M4-M8 )	4-M8 ( M6-M12 )	4-M12 ( M8-M12 )
D7	φ 52	φ 70	φ 100	φ 145
D8	4-M5X10L	4-M6X12L	4-M10X20L	4-M12X24L
D9	M5X0.8P	M8X1.25P	M10X1.5P	M16X2P
L1	35	40	55	87
L2	31	35	49	80
L3	3	3	4	5
L4	62	78.5	110	149
L5	159	213.5	303	333
L6	5(4-6)	8(5-8)	8(5-8)	5 ( 5-7 )
L7	32(32-44)	42(42-60)	70 ( 59-70 )	86 ( 62-86 )
L8	66(66-88)	95.5(95.5-113.5)	130 ( 119-130 )	165.5 ( 165.5-189.5 )
C1	60(60-90)	90(90-130)	130 ( 120 )	175 ( 142 )
S1	3	3	5	5
S2	25	30	40	70
S3	16	22.5	28	43
B	5	6	8	12
K1	4	6	8	10
K2	φ 11	φ 22	φ 28	φ 38
K3	12.8	24.5	31.3	41.3
K4	φ 16	φ 32	φ 38	φ 48
K5	15	20	27	35
K6	18	24	32	40

# RIGHT ANGLE GEARBOX

## ZR

Low rotating backlash  
less than 10 seconds

- The right angle reducer is processed using a high precision six axial machine. It is clamped and finished all in one process.
- Transmission gears can achieve low rotating backlash and high accuracy through precision grinding.
- Precision transmission and quiet, stable operation can realize low noise, high rigidity and other requirements.



## Features

- The reducer body with a compact structure and small volume to save the mounting space.
- Although the reducer is small in volume and light in weight, and it features of high torque output and low backlash.
- When ordering, please inform the sizes of motor flange and shaft.





## Model Identification

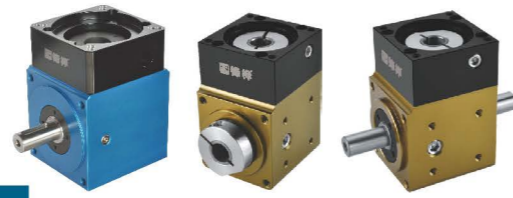

**ZR** — **090** — **3** — **P**

Right Angle Reducer

Specifications

Ratio

Output mode

P: Single output shaft  
2P: Double output shaft  
H: Hole output  
S: with planetary gearbox

## Specification

Model No.	Description	Ratio	Allowable Max Torque (kgf.m/N.m)	Breaking Torque (kgf.m/N.m)	Allowable Max Speed (rpm/min)	Backlash (min-arc)	Weight (kg)
ZR090		2 / 3	12/120	32/320	2500	0.5	3.6
ZR090S		6.8.10.14.20	12/120	32/320	2500	2	6.5

## Dimensions Unit: mm

### ZR-090P

Single output shaft

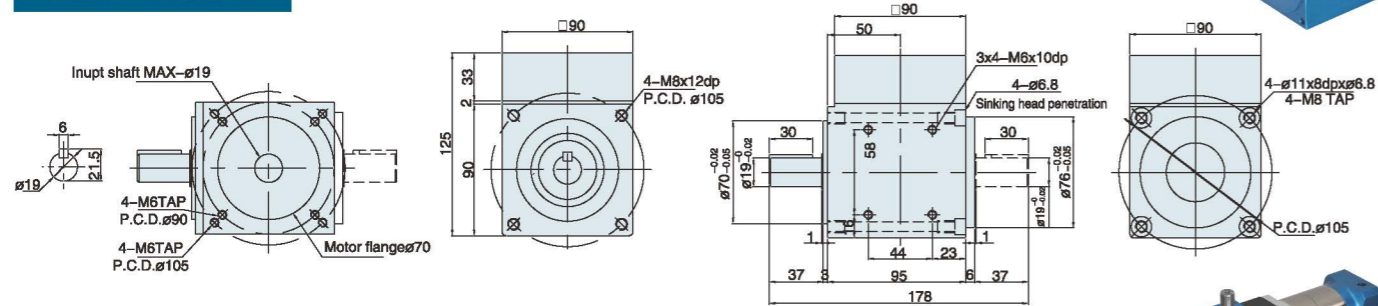

### ZR-090S

with planetary gearbox

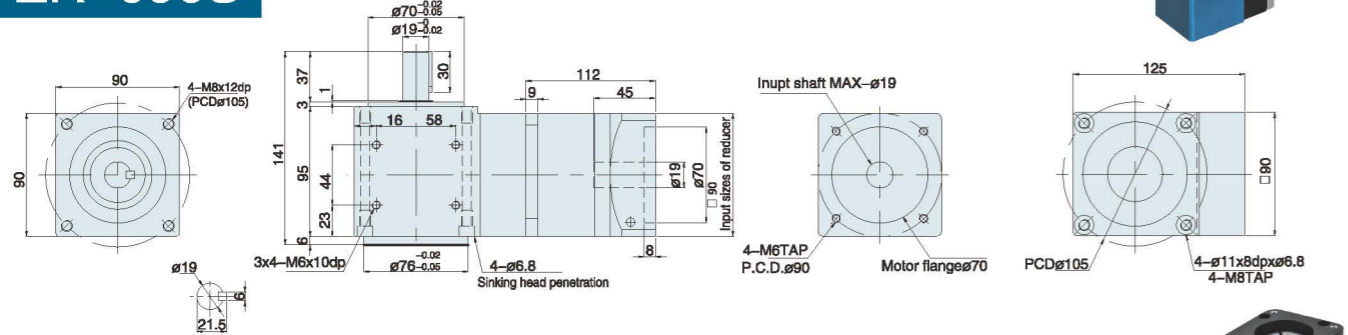

### ZR-090H

Hole output

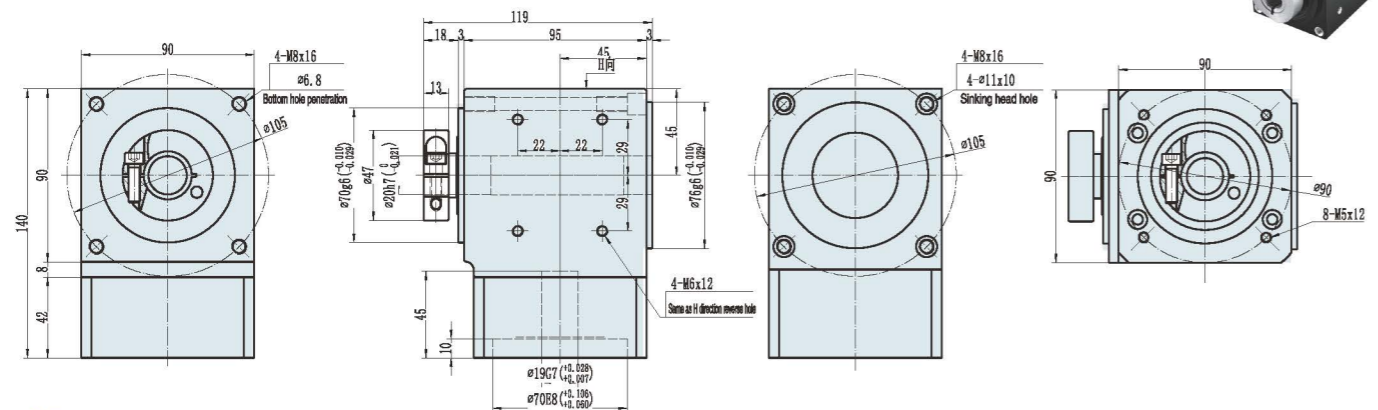
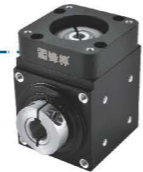

## Model Identification



**ZR** — **120** — **3** — **P**

Right Angle Reducer

Specifications

Ratio

Output mode

P: Single output shaft  
2P: Double output shaft  
H: Hole output  
S: with planetary gearbox

## Specification

Model No.	Description	Ratio	Allowable Max Torque (kgf.m/N.m)	Breaking Torque (kgf.m/N.m)	Allowable Max Speed (rpm/min)	Backlash (min-arc)	Weight (kg)
ZR120		2	16/160	45/450	2500	0.5	8
ZR120S		6.8.10.14.20	16/160	45/450	2500	2	15.5

## Dimensions Unit: mm

### ZR-120P

Single output shaft

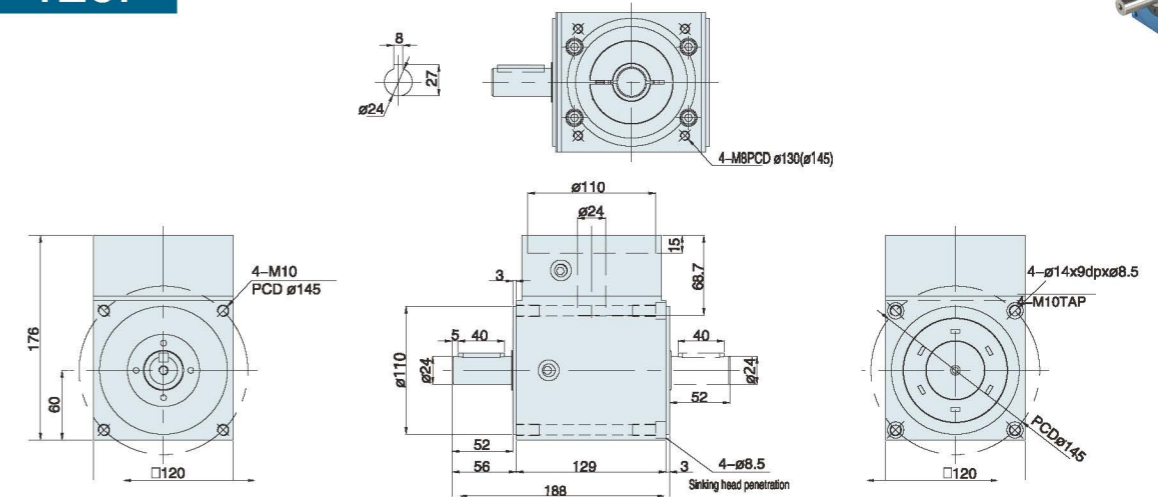

### ZR-120S

with planetary gearbox

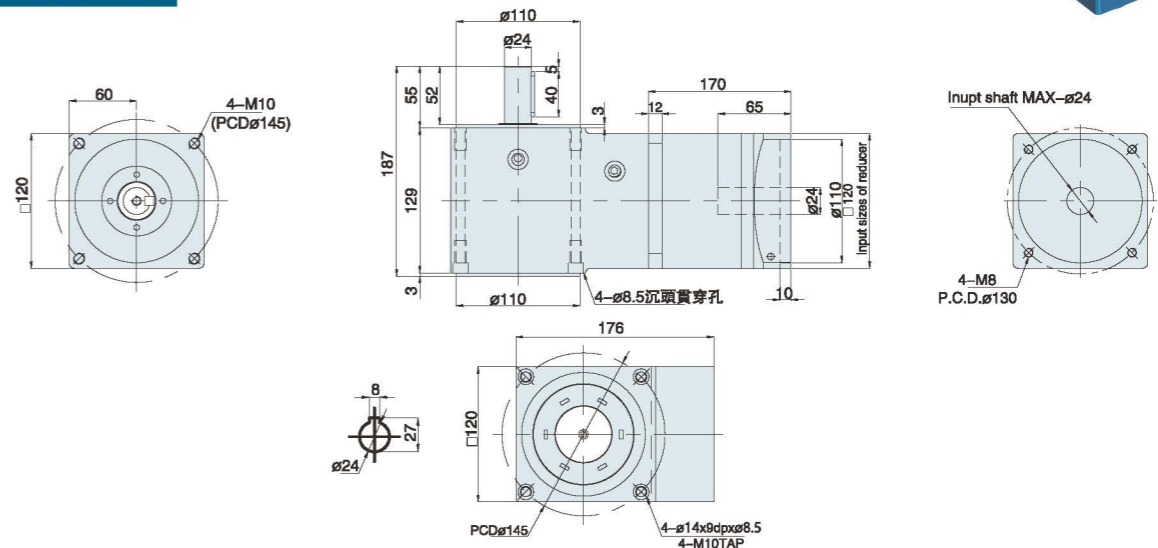

## Model Identification

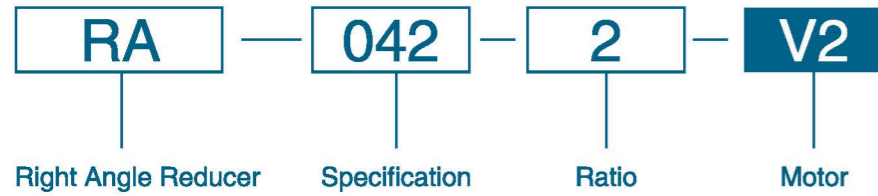

## Specification

Product model	Unit	RA□042	RA□060	RA□090	RA□120
Ratio	I	1:2/1:3	1:2/1:3	1:2/1:3	1:2/1:3
Rated output torque T <sub>2N</sub>	Nm	14	22	45	95
Max. Torque T <sub>2Not</sub>	Nm	42	65	130	200
Rated speed n <sub>1n</sub>	rpm	1500	1500	1500	1500
Max.speed n <sub>1B</sub>	rpm	2000	2000	2000	2000
Backlash jt	arcmin	8	8	8	8
Allowable radial force F <sub>2RB</sub>	N	300	500	900	1800
Allowable axial force F <sub>2AB</sub>	N	150	200	480	1100
Moment inertia J <sub>1</sub>	Kg.cm <sup>2</sup>	0.025	0.07	0.07	0.12
Working efficiency η	%	95%	95%	95%	95%
Service life L <sub>h</sub>	h	≥20000	≥20000	≥20000	≥20000
Temperature T	°C	-15°C~90°C	-15°C~90°C	-15°C~90°C	-15°C~90°C
Noise level	Db	≤65	≤65	≤66	≤66
Lubricant	Lub	Synthetic grease	Synthetic grease	Synthetic grease	Synthetic grease
Protection class	PC	IP65	IP65	IP65	IP65
Mounting direction	MP	Any direction	Any direction	Any direction	Any direction
Weight	kg	0.7	1.3	4.0	8.5

\* The above technical parameters are for reference only, and the actual specs and dimensions are issued according to the data provided by customers.

## Dimensions Unit: mm

### RA042-L1-2-8-30

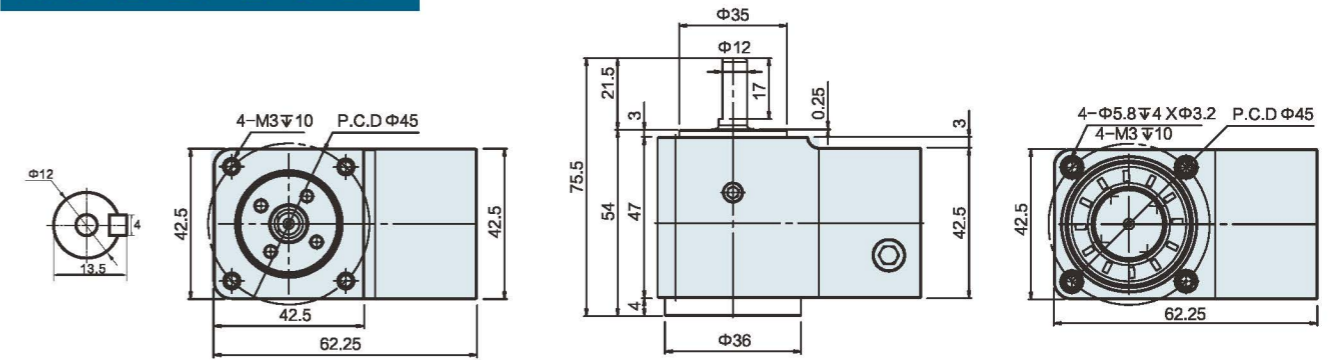

### RA060-L1-2-14-50

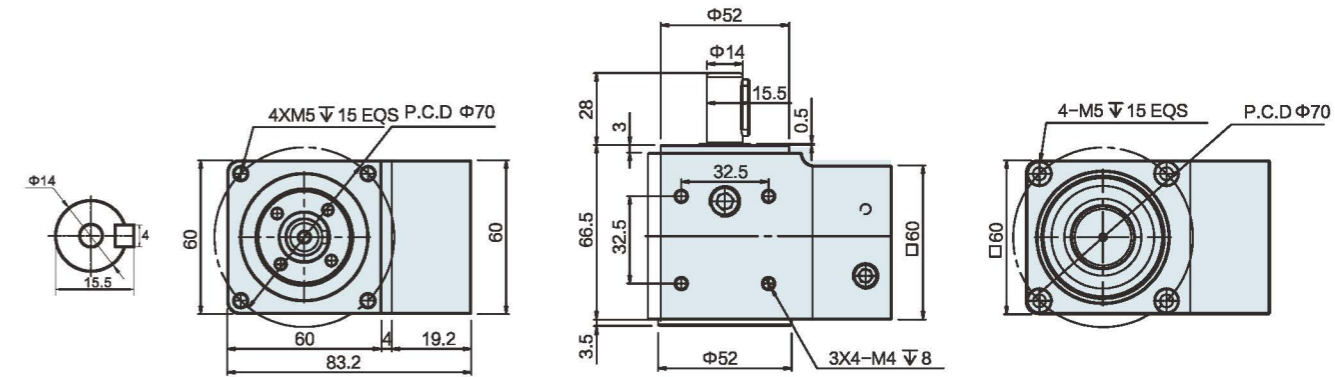

### RA090-L1-2-19-70

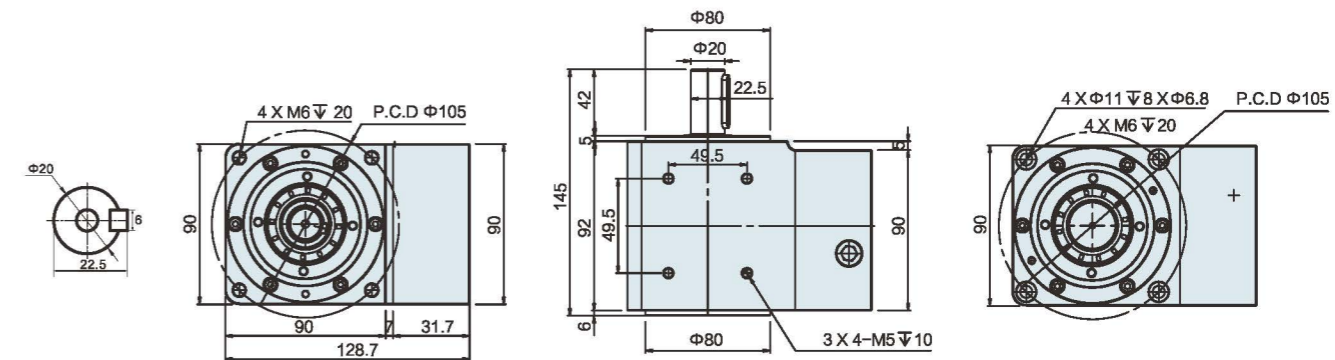

### RA120-L1-2-22-110

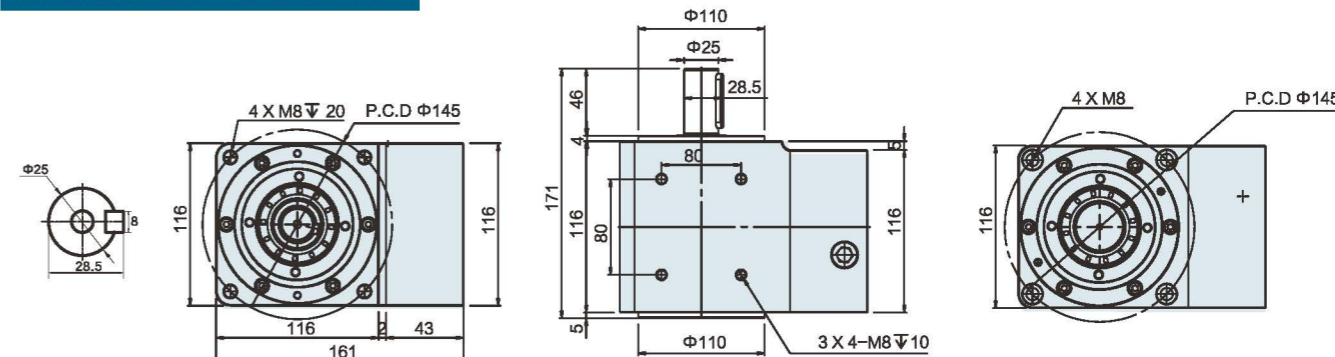



# RM Series

## Right-angle Hollow Rotating Platform



## Ordering Representation

**RM** - **130** - **30** - **14** - **50** - **70**

Series      Model      Ratio      Motor Shaft Diameter      Motor Pilot Diameter      Motor P.C.D

RM      130, 180, 260      LI: 15/21/30, L2: 60/75/105/120, 150/210/300      Attention: ( Servo Motor P.C.D) ( Stepper Motor P.C.D)

## Technical Parameter

Model		RM130			RM180			RM260		
Bearing structure		Cross roller bearing								
Reduction ratio	i	15	21	30	15	21	30	15	21	30
Rated output torque	N.m	150	130	105	430	400	360	2950	2650	2200
Output torque	N.m	3 Times rated torque								
Positioning accuracy	arc-min	≤2								
Repeated positioning accuracy	arc-sec	≤30								
Allowable disk speed	rpm	200 Intermittent operation								
Adapt to servo motor	W	200-400			750-1500			2000-5000		
Suitable for stepping motor		57 Stepper			86/110 Stepper			130/150 Stepper		
Allowable axial load	N	7300			13500			29600		
Allowable radial load	N	7300			13500			29600		
Design load	Kg	50			150			1000		
Allowable moment of inertia	N.m	50			110			750		
Torsional rigidity	N.m/arcmin	25			45			175		
Overturning moment	N.m	520			1420			6300		
Accuracy life	h	20000h Intermittent operation								
Protection level	IP	54								
Lubrication method		Long-term lubrication								
Installation method		Arbitrary								
Concentricity of rotating platform	mm	≤0.01								
Parallelism of rotating platform	mm	≤0.01								
Transmission efficiency	%	95			95			95		
Noise	db	≤57			≤63			≤63		
Weight	Kg	7			17			17		

**Attention:** If the parallelism of the rotating platform has higher requirements, please contact our sales staff

## Outline Dimensional

### RM130- ( 15/21/30 Ratio for Servo Motor 200-400W, 57 Stepper Motor )

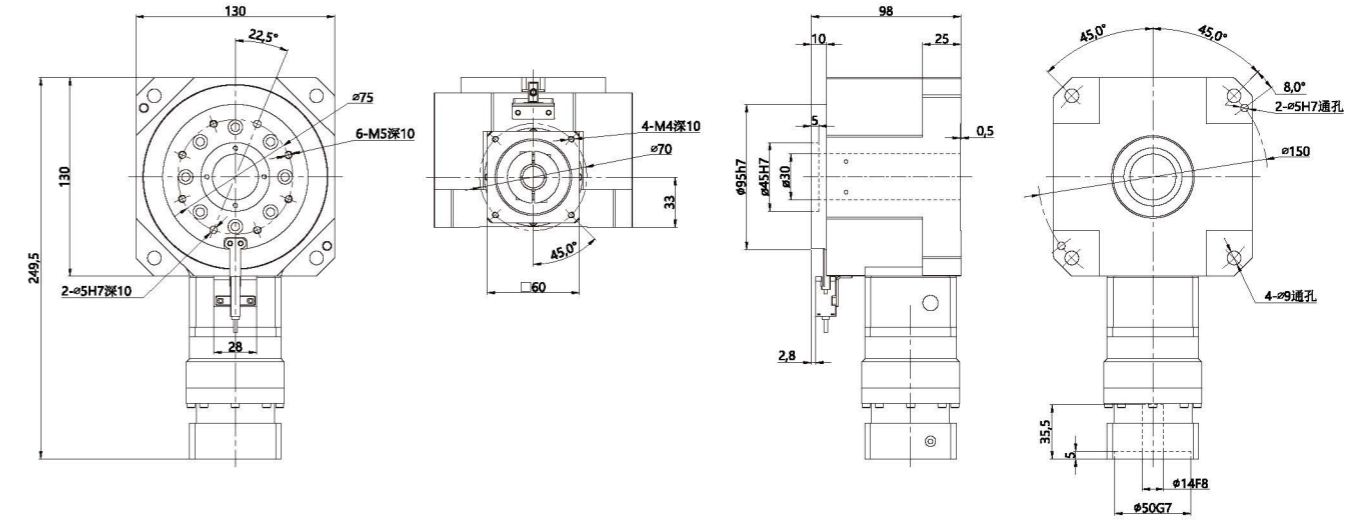

### RM180- ( 15/21/30 Ratio for Servo Motor 750-1500W, 86/110 Stepper Motor )

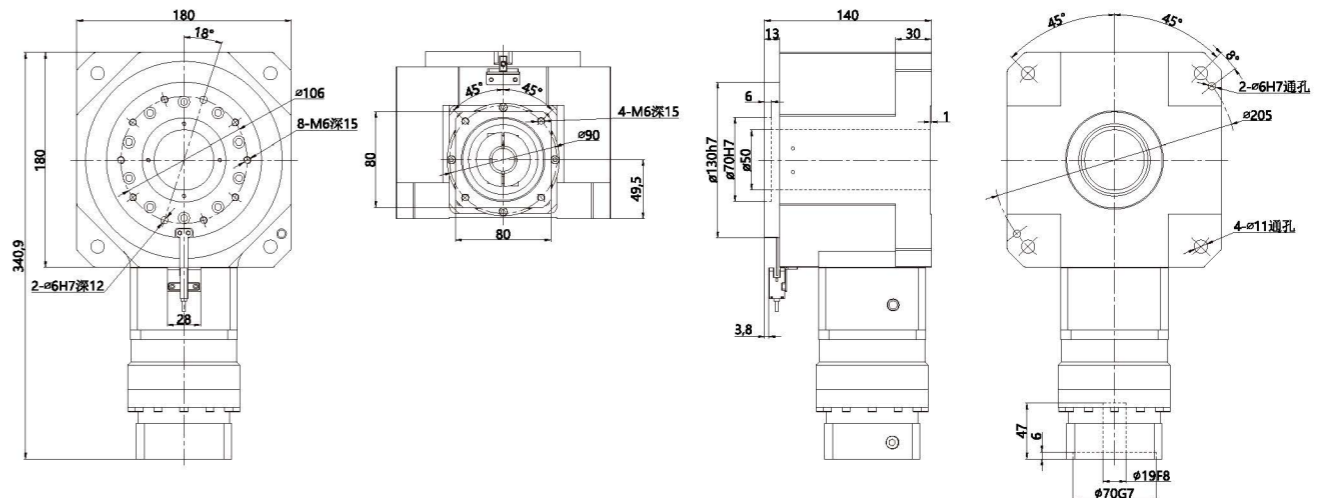

### RM260- ( 15/21/30 Ratio for Servo Motor 2000-5000W, 130/150 Stepper Motor )

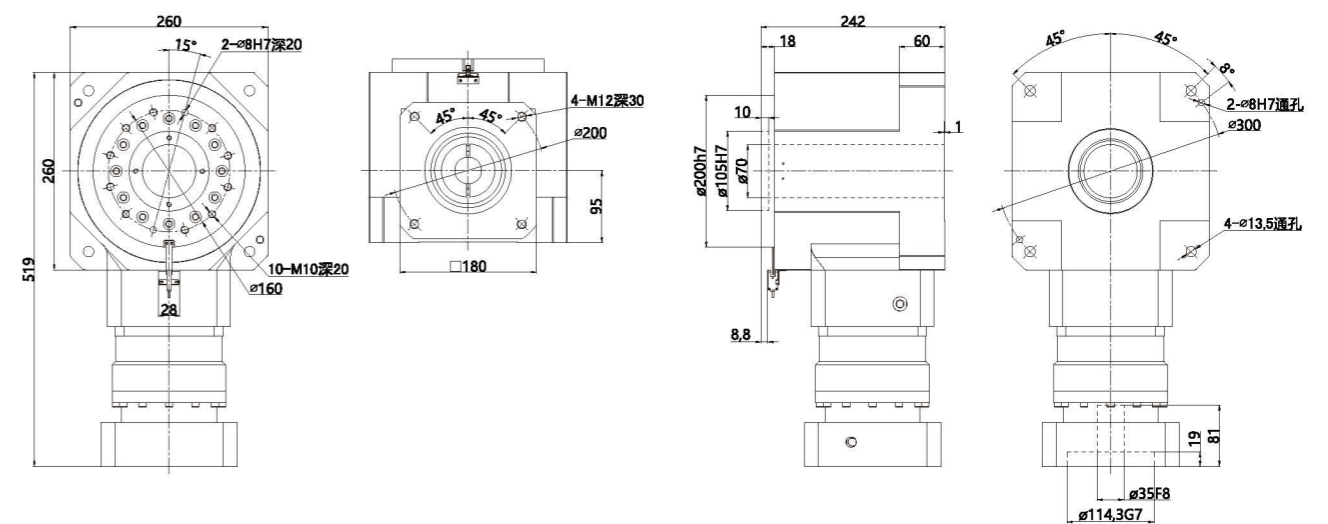

\* Specifications mentioned above are for reference, the actual parameter situation is based on the tech data provided

# Hollow Rotary Actuator

ZK



- Working objects can be locked directly  
The rotating disk surface can directly lock the working objects, and therefore improve the convenience of the workpiece transfer.
- Wiring convenience  
Featured with a hollow design, the rotating platform is convenient for wiring or piping.



- Alternative D.D motor and cam splitter  
Straight lines motions and circular motions are two kinds of mechanical movements. Linear motion are mainly based on various types of slides, while circular motions are the most representative motion of cam indexers. And due to the maturity of technology and the accuracy requirement of equipment, D.D motor is becoming more and more popular. However, the traditional splitter has been unable to meet the needs of any segmentation. Though D. D Motor can be applied in multiple ways and with high precision, its high price is the main factors that make user reconsider. ZK series hollow rotating table has successfully got a balance between the cam indexers and D.D motor. It fills the functional requirements that not only can greatly reduce the cost of D.D Motor, but also can meet the high-precision and digital control that the cam divider can't provide.

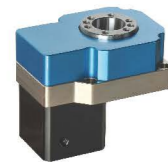

ZK60-5-5A

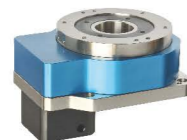

ZK100-8



ZK130-10

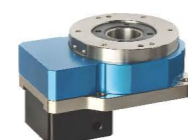

ZK200-10

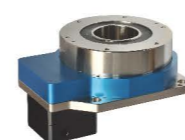

ZK275-10

- High positioning accuracy. Repeatability positioning accuracy is  $\pm 15$  sec and idling accuracy is 2 min

Ultra-precision machined gears are used in the speed reduction mechanism to eliminate the backlash through its own adjustment mechanism, thus there will be no backlash in the part of mechanism. As repeated positioning accuracy is  $\pm 15$  sec in one direction and idling precision is 2 min in two directions, positioning with high accuracy is possible.

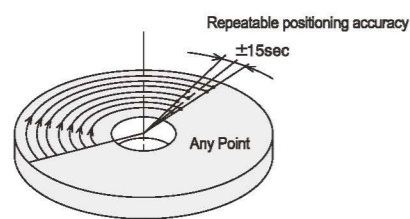

- Direct connection - simple design enhances trust

The worktable and robot arm of the equipment can be installed directly on the hollow output platform. When the general equipment positions and operates by means of pulleys and other mechanical parts. It is mostly affected by the transmission efficiency of the mechanical parts and therefore the accuracy is reduced, or there is a need to maintain the parts of the mechanism. While the ZK series hollow rotary actuators can be installed directly without intermediate parts. Therefore, in addition to the direct use of the accuracy of the actuator itself, maintenance can be avoided.

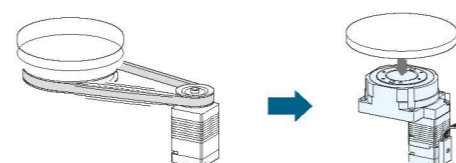

## Calculation of Selection

Pre-calculation should be done in order to select suitable products of equipment. The introduction of calculation methods of the ZK series are as follow.

### The calculation of the necessary torque

- Firstly, calculate the inertia of the working object.  
The work inertia should be under the 30 times of the inertia of the transmission equipment.
- Determine the positioning angle
- If there is no friction torque, please refer to the positioning time chart of ZK series to confirm the positioning time.
- Determine the positioning time and acceleration and deceleration time.  
Observe the following two conditions:  
Positioning time  $\geq$  Calculating the shortest positioning time according to the positioning time chart.  
Time of acceleration and deceleration  $t \times 2 \leq$  Positioning time
- Determine the start speed  $N_1$ , then calculate the speed  $N_2$  according to the following formula. Please set  $N_1$  to low speed 0- number r/min. Be careful not to set it too large.

$$N_2 [r/min] = \frac{\theta - 6N_1 t_1}{6(t - t_1)}$$

- $N_2$ : Speed (r/min) [r/min]
- $\theta$ : Positioning angle[°]
- $N_1$ : Start speed[r/min]
- $t$ : Positioning time [s]
- $t_1$ : Acceleration (deceleration) time [s]

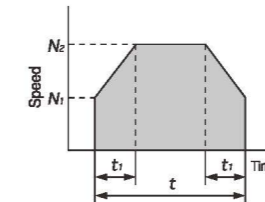

If the result calculated by the above formula can not satisfy the condition of  $N_1 < N_2 \leq 200$  (r/min), please return to procedure 4 and confirm the conditions again.

- Calculate the acceleration torque according to the following formula

$$\text{Acceleration torque } T_a [N \cdot m] = (J_1 + J_2) \times \frac{\pi}{30} \times \frac{(N_2 - N_1)}{t}$$

- $J_1$ : Inertia of a rotating drive [ $kg \cdot m^2$ ]
- $J_2$ : Inertia [ $kg \cdot m^2$ ]
- $N_2$ : [r/min]
- $N_1$ : Starting speed [r/min]
- $t$ : Acceleration (deceleration) time [s]

- Calculate the necessary torque, the necessary torque is the load torque caused by the friction impedance plus the acceleration torque caused by the inertia, and then multiplied by the safety factor.

$$\text{Necessary torque} = (\text{Load torque } [N \cdot m] + \text{Acceleration torque } [N \cdot m]) \times \text{Safety factor} = (T_L + T_a) \times S$$

Please set safety factor S above 1.5.

- Verify that the necessary torque T is included in the range of speed and torque characteristics. If not, please turn back to step 4, then change the conditions and recalculate.

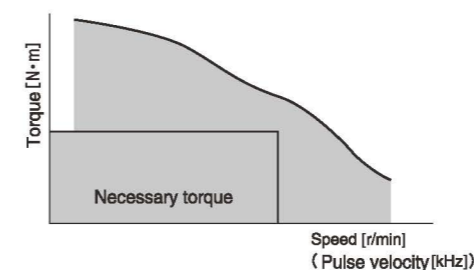

In addition, when the speed is converted to the pulse speed, please calculate the following the below formula.

$$f [Hz] = \frac{6N}{\theta s}$$

- $f$ : Pulse velocity [Hz]
- $N$ : speed [r/min]
- $\theta_s$ : The step angle of the rotating platform[° /step]

### The calculation method of the steering load and the inertia load

As shown below, when the load is loaded on the rotary platform, please calculate the axial load and mass load according to the formula below, and confirm whether it is within the specification value.

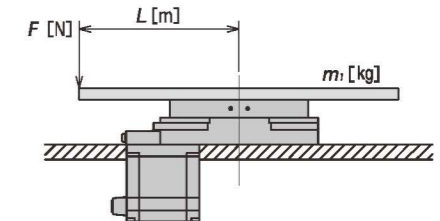

$$\begin{aligned} \text{Axial load } [N] &= F + m \cdot g \\ \text{Inertial load } [N \cdot m] &= F \cdot L \end{aligned}$$

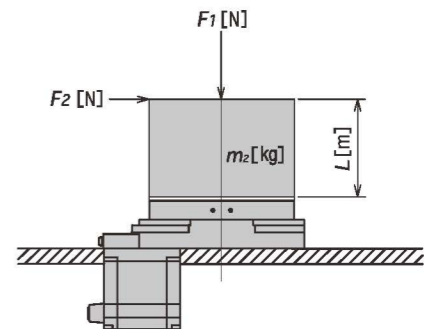

Product Name	a
ZK-60	0.01
ZK-100	0.02
ZK-130	0.03
ZK-200	0.04
ZK-275	0.05

$$\begin{aligned} F_s &= F_1 + m_2 \cdot g \\ M &= F_s \cdot (L + a) \end{aligned}$$

### Variable quantity (reference value) caused by an inertial load

When attaching the inertia load to the rotating platform, the position will change. The variable quantity in the chart shows the change of inertia load on the L position of the center of rotation from the rotating platform to a fixed direction. If the inertia load acts on the positive and negative two directions, the variable quantity will be about 2 times.

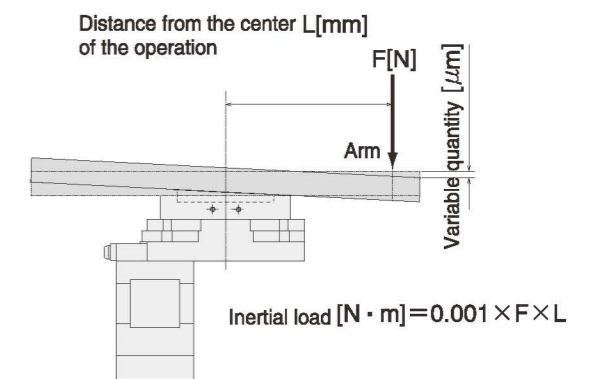

# Model Identification



R: Right angle steering deceleration F: with motor connection seat	V1: Servo Ø8 PCD45,M3	T1: Stepper Ø5 PCD43.8, M3
	V2: Servo Ø8 PCD46,M4	T2: Stepper Ø6 PCD43.8, M3
	100W AC servo motor for each brand	42 stepper motor for each brand

# Specification

Model	ZK60	ZK60R
Bearing of rotate table	Deep groove ball+Thrust ball bearing	
Allowable torque (N.m)	5	
Precision lifetime	15000Hrs	
Allowable speed (rpm)	200( Plate)	
Ratio	5	15
Repeated accuracy(arc-sec)	≦ 15	≦ 20
Positioning accuracy(arc-min)	≦ 1	≦ 1
Parallelism of rotate plate(mm)	≦ 0.02	
Coaxiality of rotate plate(mm)	≦ 0.02	
Protection Class	IP40	

P.S: Circumferential unit: 1 rpm=360° 1° =60'(arc-min) 1'=60"(arc-sec)  
Circumferential error conversion linear error:Disc diameter × 3.14159 ÷ (360° × 60' × 60")The value of backlash

# Positioning Accuracy Examination

The accuracy of this specification is tested by this ratio

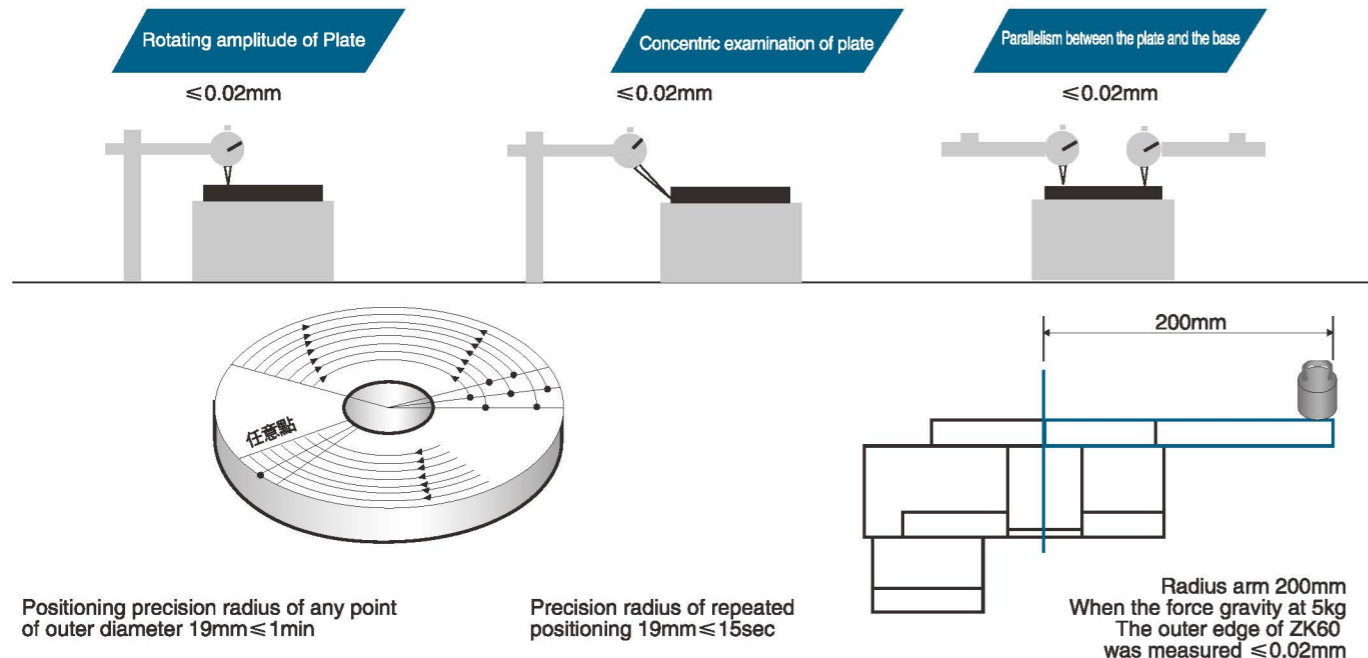

# Dimensions Unit:mm

## ZK60-5-5A ( This model contains stepper motor 42H5K-2A)

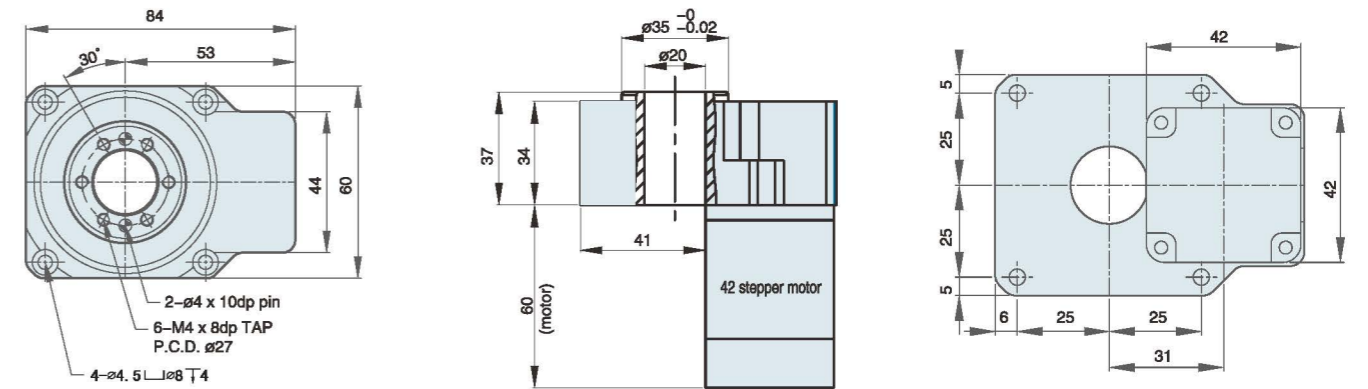

## ZK60F-5 ( A self assembled motor with a connecting seat)

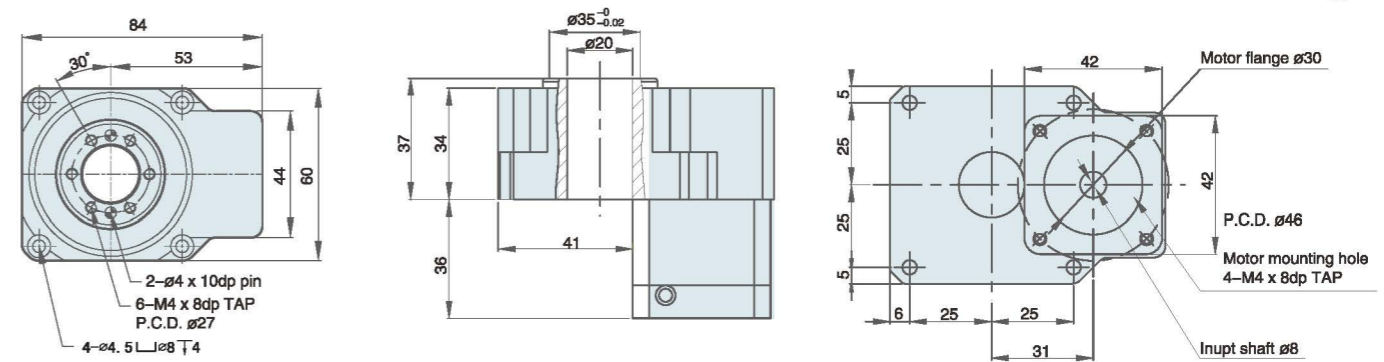

## ZK60R-15 ( Right angle steering 1:15)

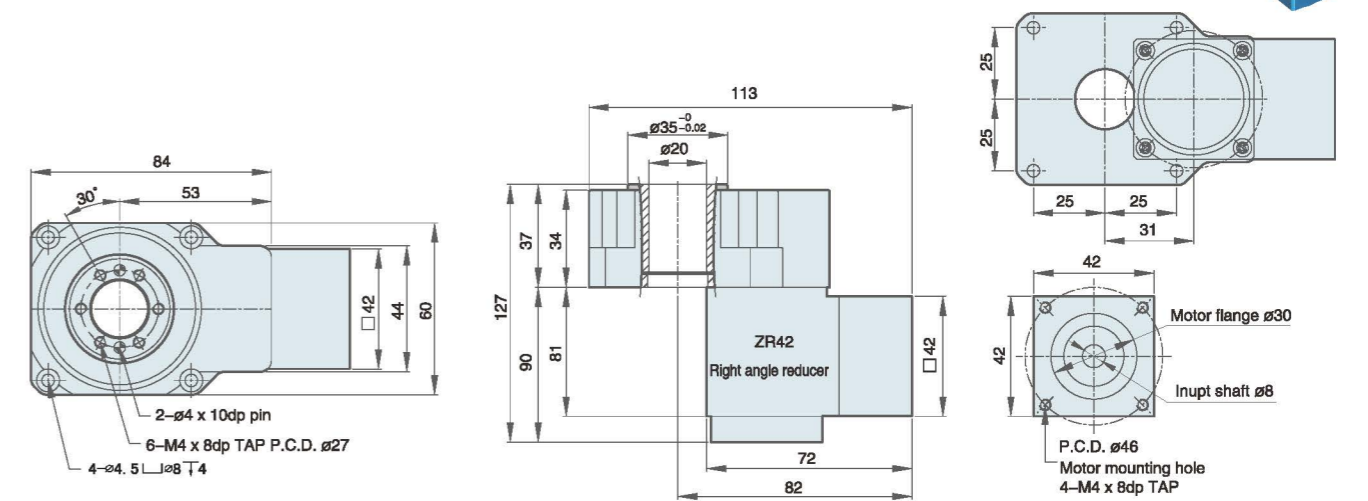

※ Please provide the size of the motor flange when ordering  
P.S: Origin Sensor specification (selection) OMRON EE-SX672

# Model Identification



R: Right angle steering deceleration  
P: Attached planetary reducer

V1: Servo Ø14 PCD70 M4 V2: Servo Ø14 PCD70 M5	T1: Stepper Ø8 PCD66.67,M4 T2: Stepper Ø8 PCD70,M4 T3: Stepper Ø10 PCD70,M4
200~400W AC servo motor for each brand	60 stepper motor for each brand

# Specification

Model	ZK100	ZK100R	ZK100P
Bearing of rotate table	Tapered roller bearing		
Allowable torque (N.m)	45		
Precision lifetime	20000Hrs		
Allowable speed (rpm)	200(Plate)		
Ratio	8	16,24	24,32,40
Repeated accuracy(arc-sec)	≤10	≤20	≤60
Positioning accuracy(arc-min)	≤1	≤1	≤2
Parallelism of rotate plate(mm)	≤0.02		
Coaxiality of rotate plate(mm)	≤0.015		
Protection Class	IP40		

P.S: Circumferential unit: 1 rpm=360° 1° =60'(arc-min) 1'=60"(arc-sec)  
Circumferential error conversion linear error: Disc diameter × 3.14159 ÷ (360° × 60' × 60")The value of backlash

# Positioning Accuracy Examination

The accuracy of this specification is tested by this ratio

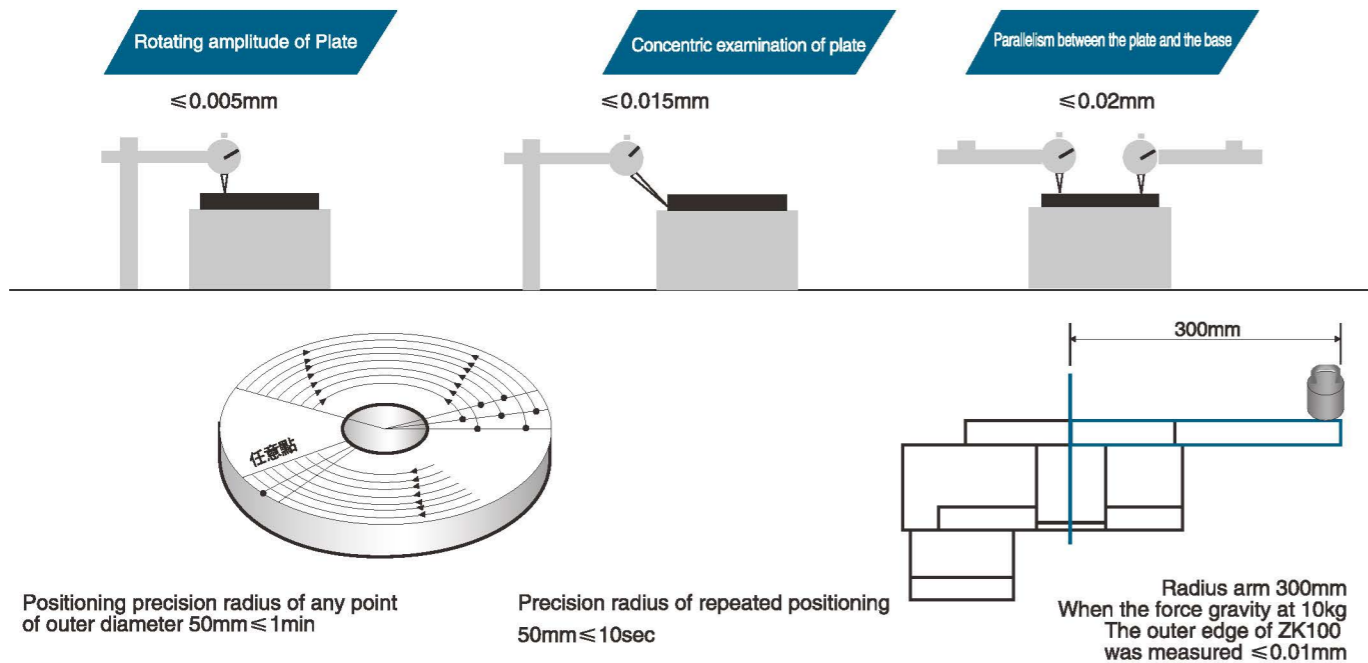

# Dimensions Unit:mm

## ZK 100 (A self assembled motor with a connecting seat)

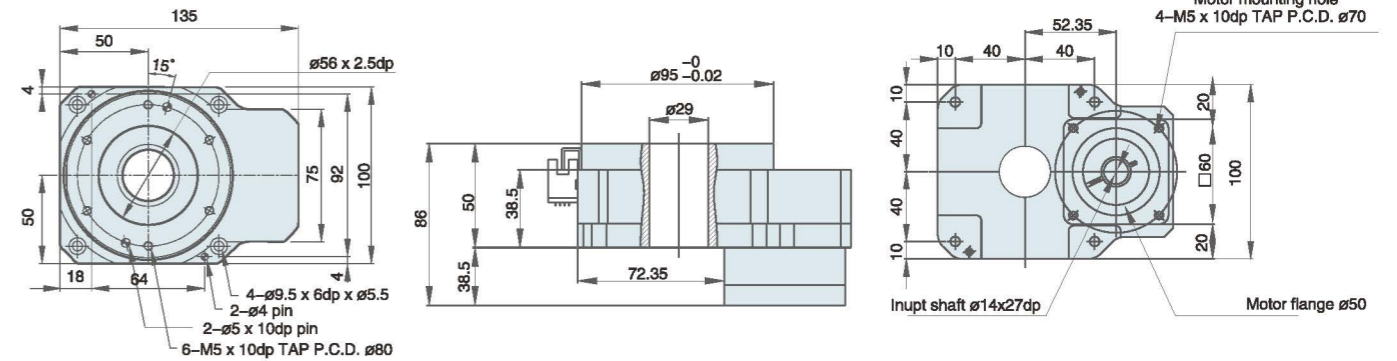

## ZK 100R (Right angle steering 1:16)

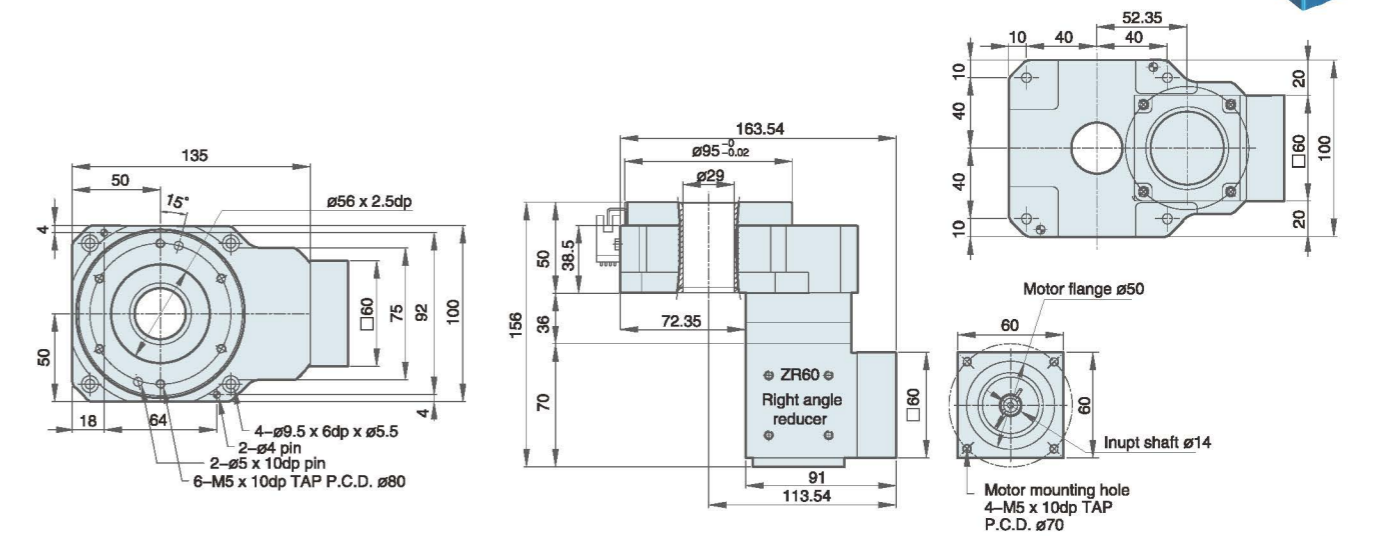

## ZK 100P (Attached planetary reducer ratio 24,32,40)

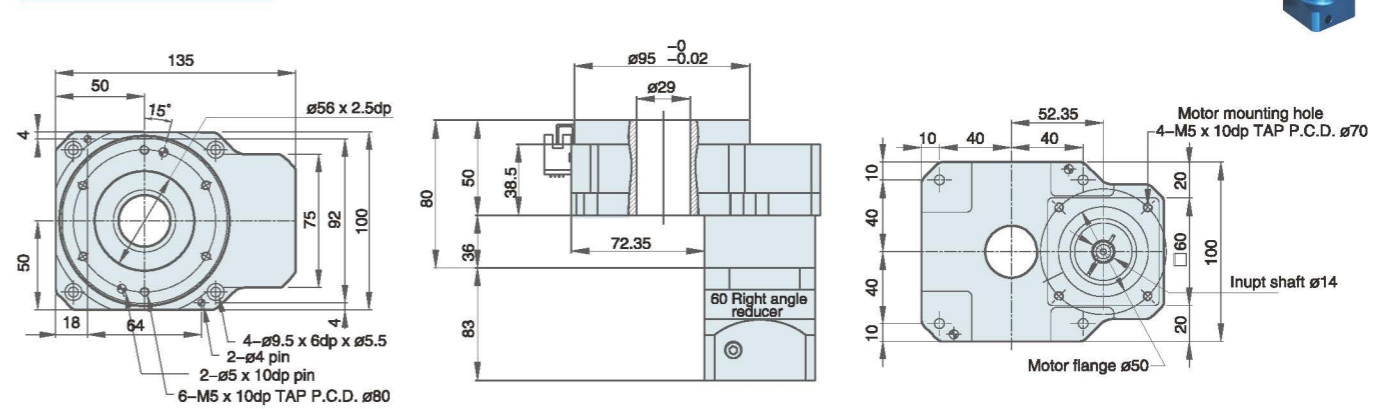

※ Please provide the size of the motor flange when ordering  
P.S: Origin Sensor specification (selection) OMRON EE-SX672

# Model Identification



R: Right angle steering deceleration P: Attached planetary reducer	V1: Servo Ø14 PCD70 M4 V2: Servo Ø14 PCD70 M5	T1: Stepper Ø8 PCD66.67,M4 T2: Stepper Ø8 PCD70,M4 T3: Stepper Ø10 PCD70,M4
	200~400W AC servo motor for each brand	60 stepper motor for each brand

# Specification

Model	ZK130	ZK130R	ZK130P
Bearing of rotate table	Tapered roller bearing		
Allowable torque (N.m)	45		
Precision lifetime	20000Hrs		
Allowable speed (rpm)	200(Plate)		
Ratio	10	20,30	30,40,50
Repeated accuracy(arc-sec)	≤ 10	≤ 20	≤ 60
Positioning accuracy(arc-min)	≤ 1	≤ 1	≤ 2
Parallelism of rotate plate(mm)	≤ 0.02		
Coaxiality of rotate plate(mm)	≤ 0.015		
Protection Class	IP40		

P.S: Circumferential unit: 1 rpm=360° 1° =60'(arc-min) 1'=60"(arc-sec)  
Circumferential error conversion linear error:Disc diameter × 3.14159 ÷ (360° × 60' × 60")The value of backlash

# Positioning Accuracy Examination

The accuracy of this specification is tested by this ratio

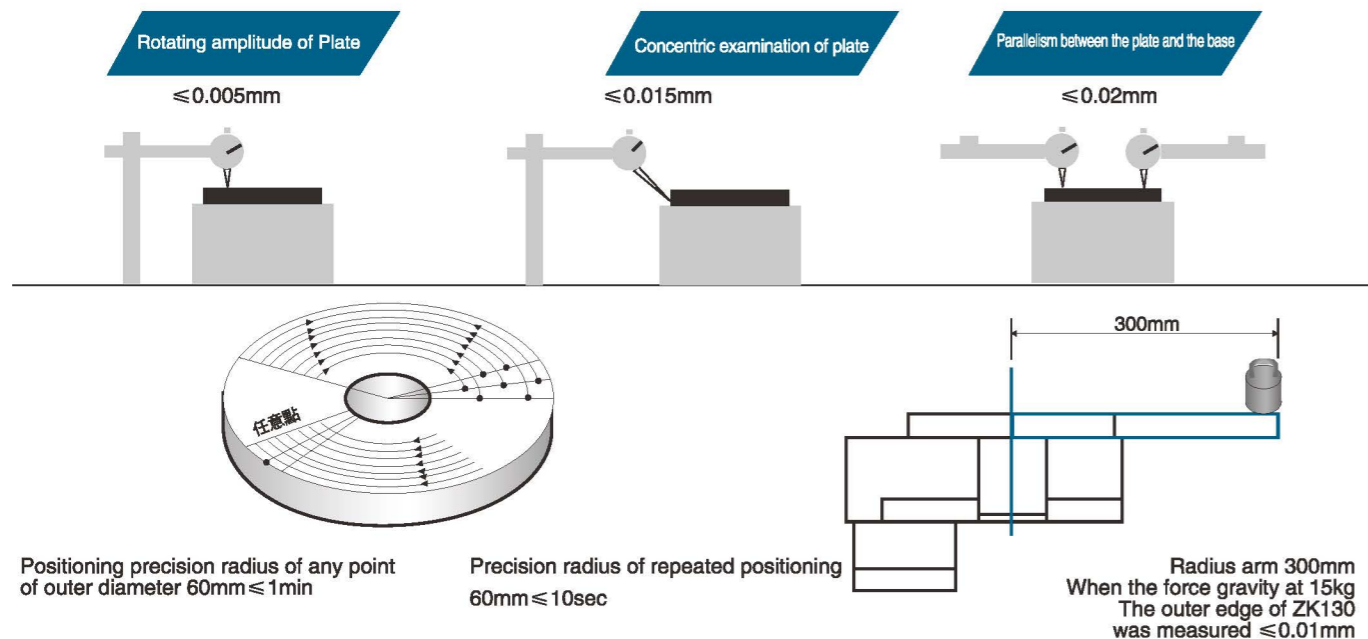

# Dimensions Unit:mm

## ZK 130 (A self assembled motor with a connecting seat)

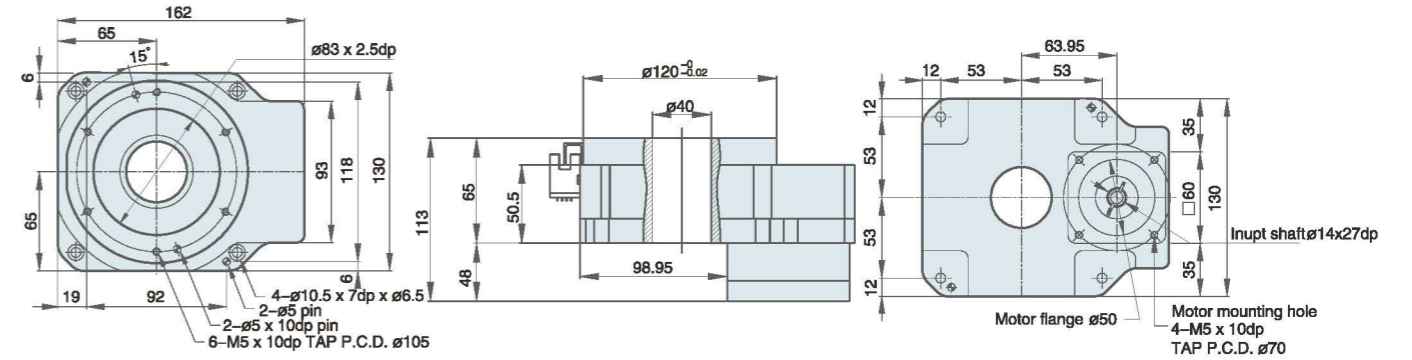

## ZK 130R (Right angle steering 1:20)

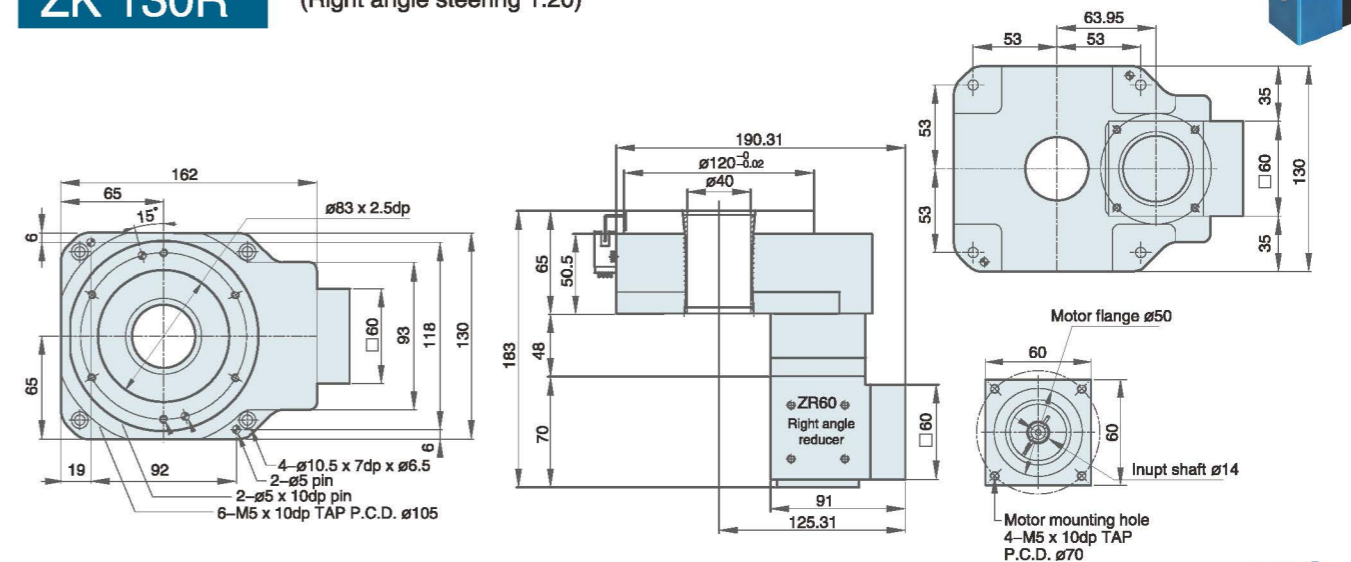

## ZK 130P (Attached planetary reducer ratio 30,40,50)

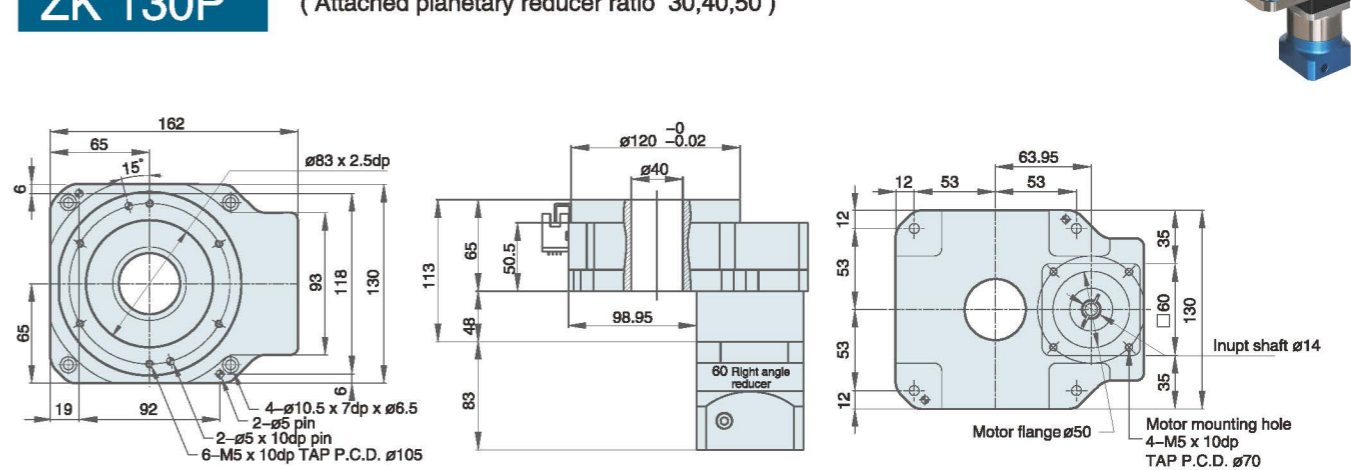

※ Please provide the size of the motor flange when ordering  
P.S: Origin Sensor specification (selection) OMRON EE-SX672

# Model Identification

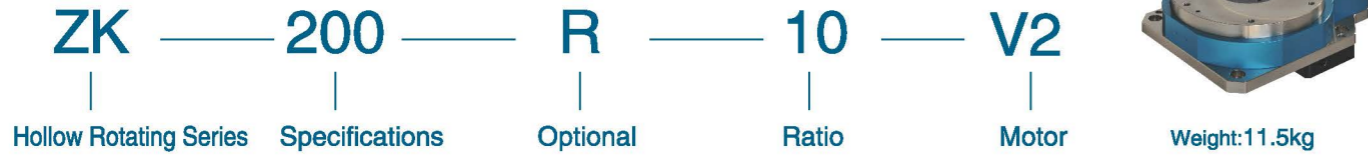

R: Right angle steering deceleration P: Attached planetary reducer	V1: Servo Ø19 PCD90 M5 V2: Servo Ø19 PCD90 M6	T1: Stepper Ø14 PCD98.4, M5
	750W AC servo motor for each brand	86 stepper motor for each brand

# Specification

Model	ZK200	ZK200R	ZK200P
Bearing of rotate table	Tapered roller bearing		
Allowable torque (N.m)	80		
Precision lifetime	20000Hrs		
Allowable speed (rpm)	200(Plate)		
Ratio	10	20,30	30,40,50
Repeated accuracy(arc-sec)	≤ 10	≤ 20	≤ 60
Positioning accuracy(arc-min)	≤ 1	≤ 1	≤ 2
Parallelism of rotate plate(mm)	≤ 0.02		
Coaxiality of rotate plate(mm)	≤ 0.015		
Protection Class	IP40		

P.S: Circumferential unit: 1 rpm=360° 1° =60'(arc-min) 1'=60"(arc-sec)  
Circumferential error conversion linear error: Disc diameter × 3.14159 ÷ (360° × 60' × 60") The value of backlash

# Positioning Accuracy Examination

The accuracy of this specification is tested by this ratio

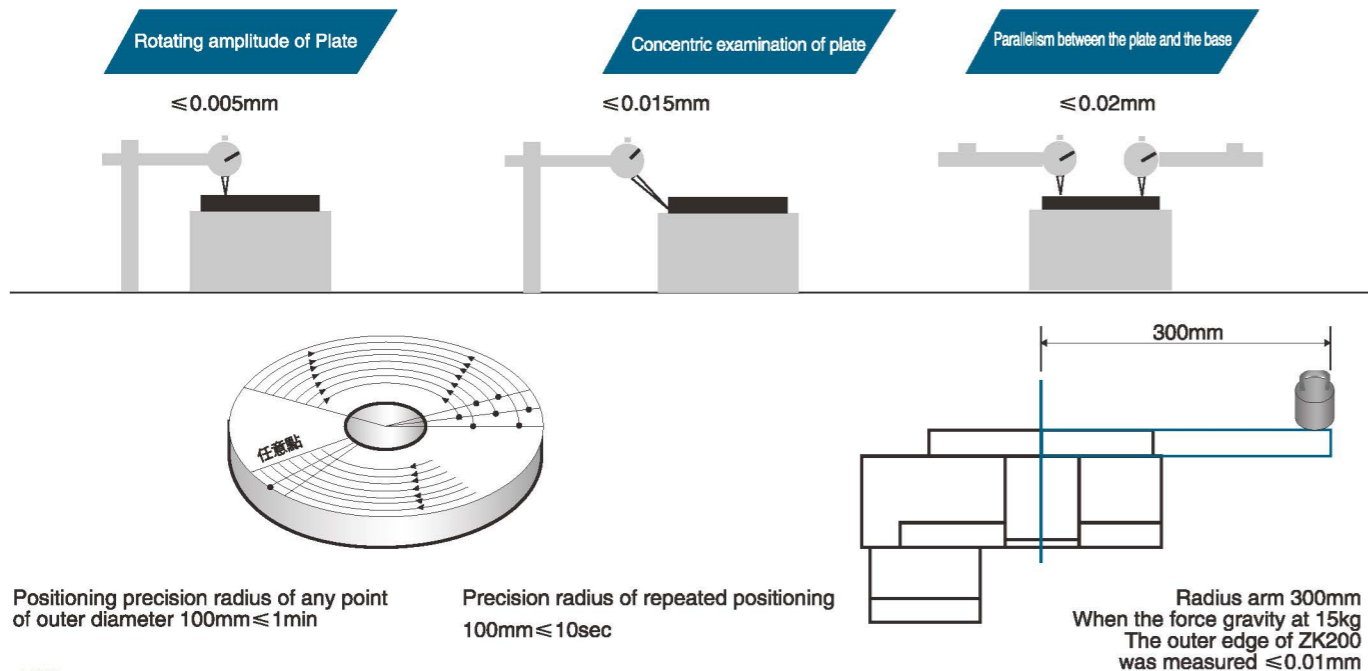

# Dimensions Unit:mm

## ZK 200 (A self assembled motor with a connecting seat)

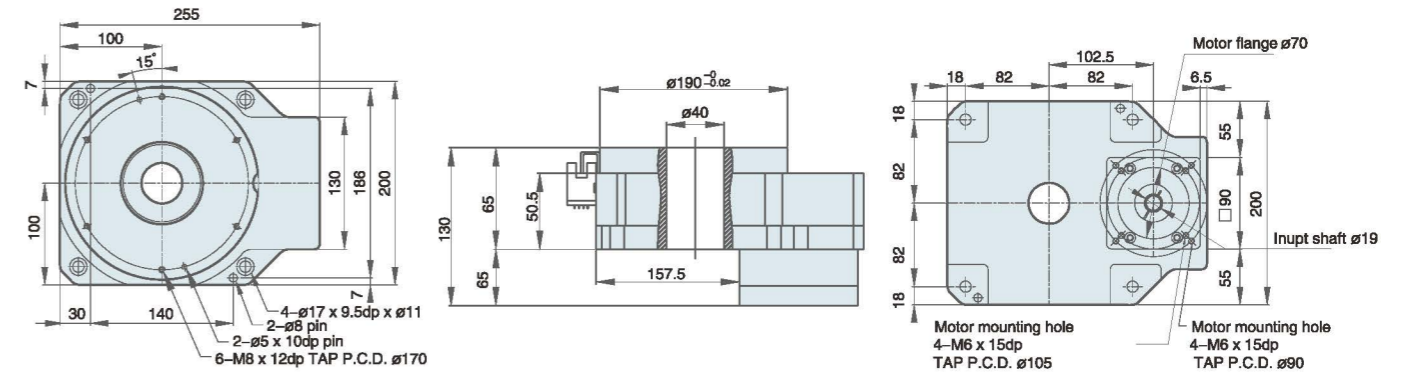

## ZK 200R (Right angle steering 1:20)

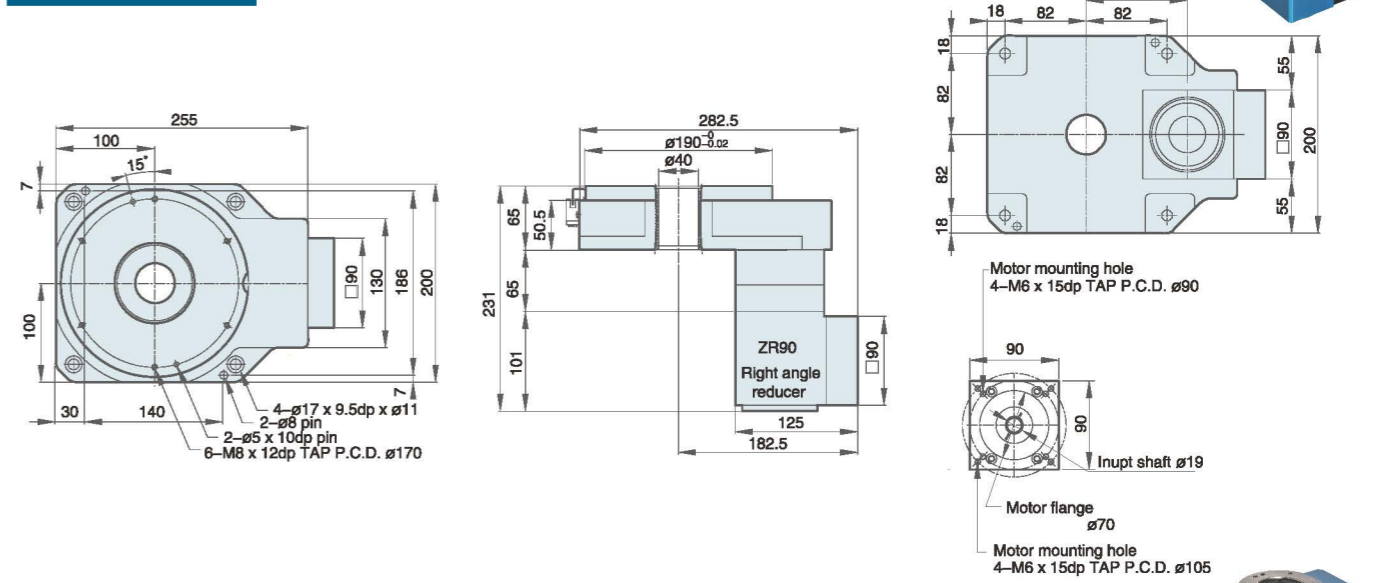

## ZK 200P (Attached planetary reducer ratio 30,40,50)

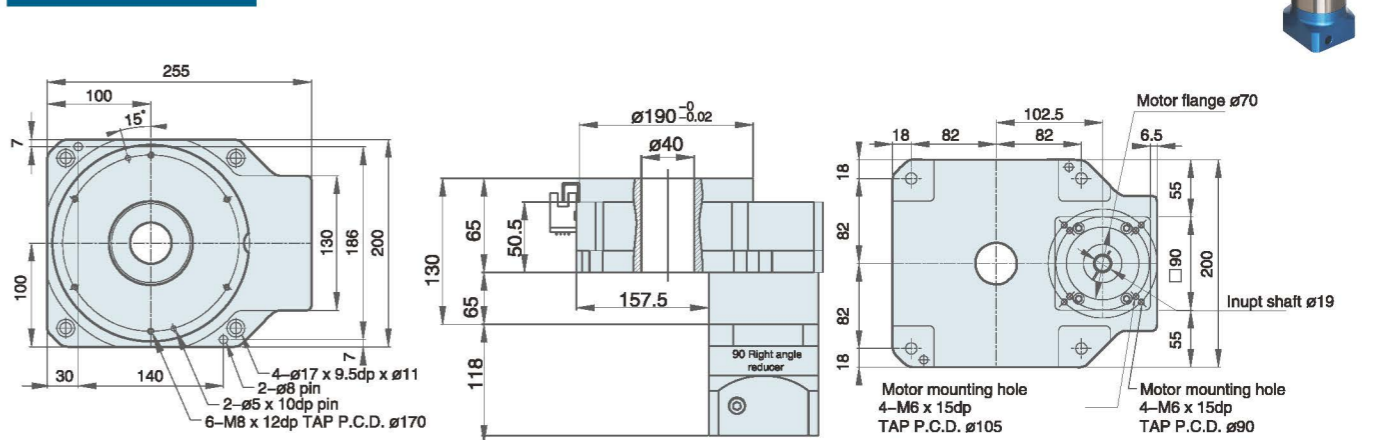

※ Please provide the size of the motor flange when ordering  
P.S: Origin Sensor specification (selection) OMRON EE-SX672

# Model Identification



R: Right angle steering deceleration  
P: Attached planetary reducer

V1: Servo Ø19 PCD90 M5 V2: Servo Ø19 PCD90 M6	T1: Stepper Ø14 PCD98.4, M5
750W AC servo motor for each brand	86 stepper motor for each brand

# Specification

Model	ZK275	ZK275R	ZK275P
Bearing of rotate table	Tapered roller bearing		
Allowable torque (N.m)	80		
Precision lifetime	20000Hrs		
Allowable speed (rpm)	200( Plate)		
Ratio	10	20,30	30,40,50
Repeated accuracy(arc-sec)	≤10	≤20	≤60
Positioning accuracy(arc-min)	≤1	≤1	≤2
Parallelism of rotate plate(mm)	≤0.02		
Coaxiality of rotate plate(mm)	≤0.015		
Protection Class	IP40		

P.S: Circumferential unit: 1 rpm=360° 1° =60'(arc-min) 1'=60"(arc-sec)  
Circumferential error conversion linear error:Disc diameter × 3.14159 ÷ (360° × 60' × 60")The value of backlash

# Positioning Accuracy Examination

The accuracy of this specification is tested by this ratio

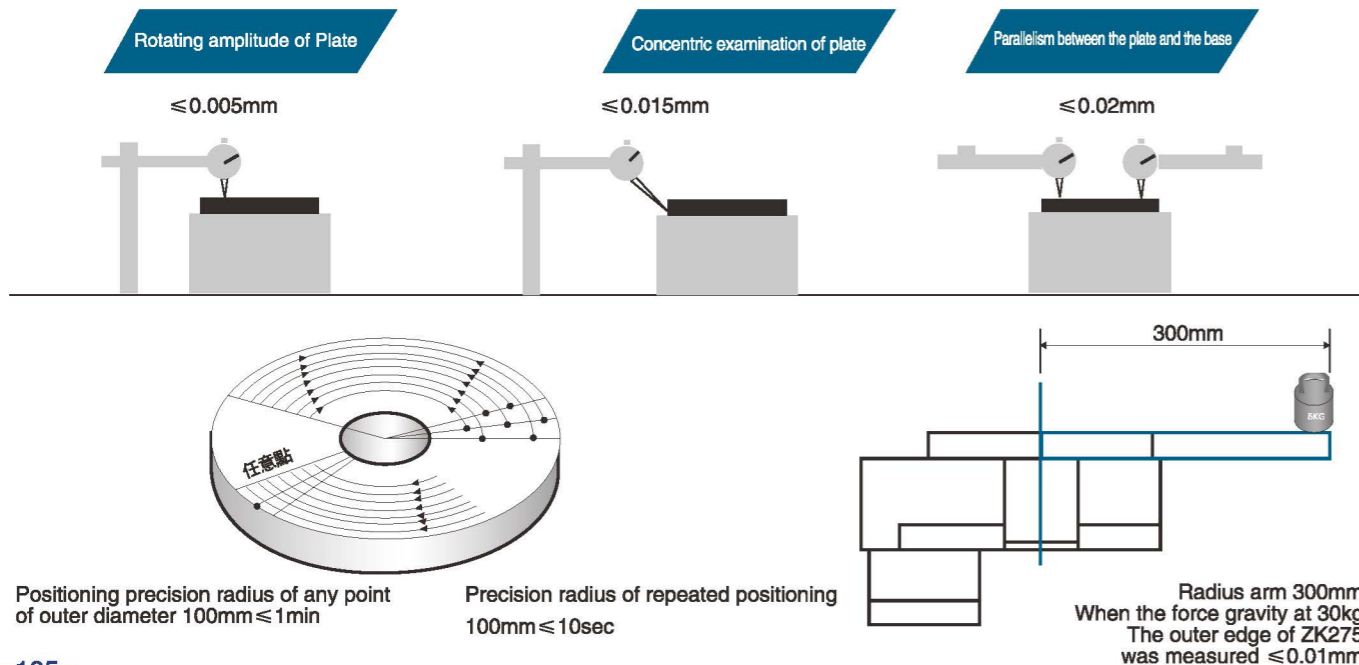

# Dimensions Unit:mm

## ZK 275 (A self assembled motor with a connecting seat)

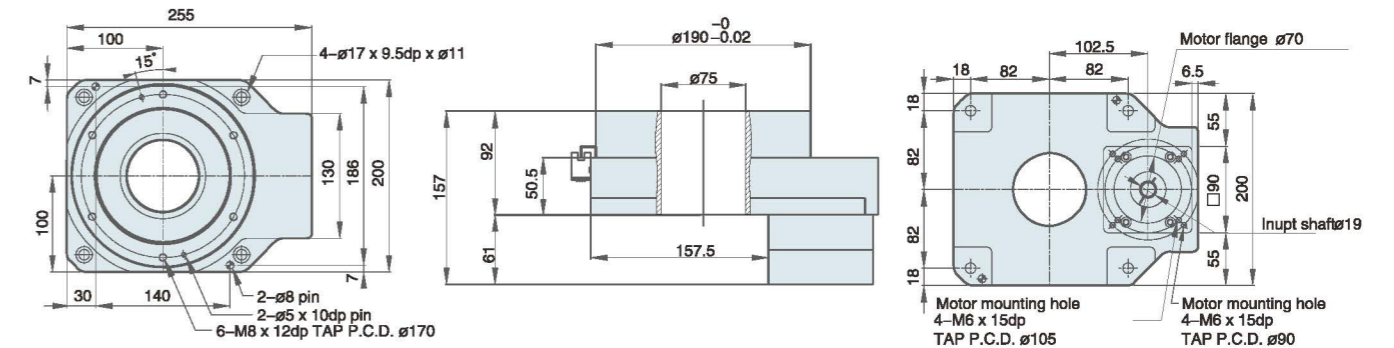

## ZK 275R (Right angle steering 1:20)

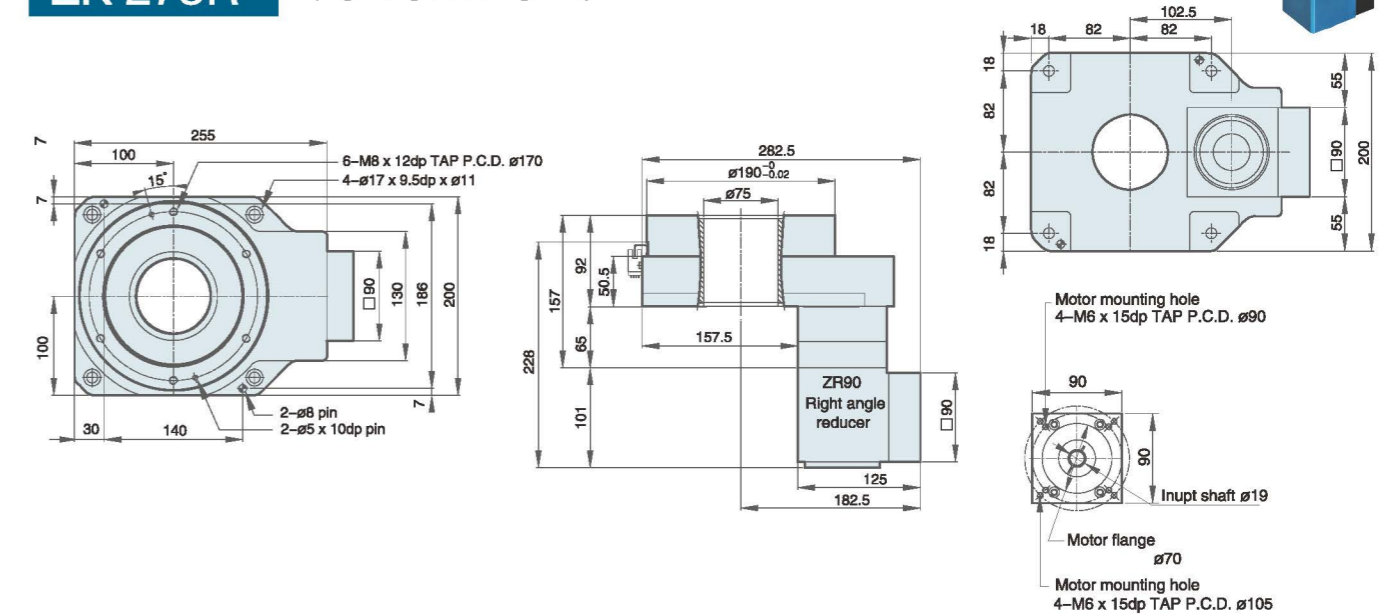

## ZK 275P (Attached planetary reducer ratio 30,40,50)

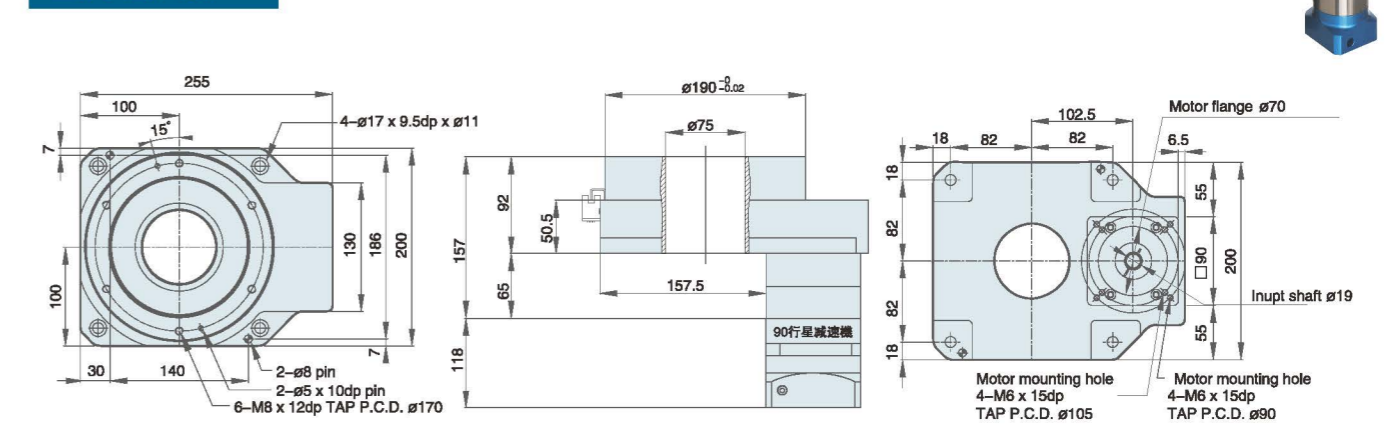

※ Please provide the size of the motor flange when ordering  
P.S: Origin Sensor specification (selection) OMRON EE-SX672

# Precision Hollow Rotary Actuator

**DG**

Hollow rotary transmission device with large diameter  
Simple wiring and piping

Direct connection  
Simple design to improve trust

Easy of origin regression  
regression thanks to the using  
the origin sensor kit  
( Choose and purchase accessories )

High positioning precision  
The accuracy of repeated positioning  
is + 15sec Lost motion is 2mins  
Angle transmission error is 4mins

Short time positioning  
The positioning of the inertial load  
can be realized in a short time

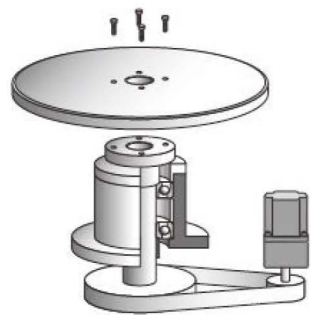

Motor + mechanism components  
(separate design \* procurement)

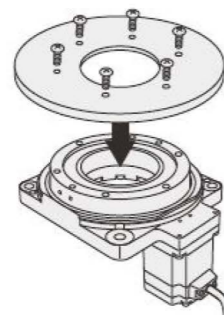

DGII series  
( Integrated product )

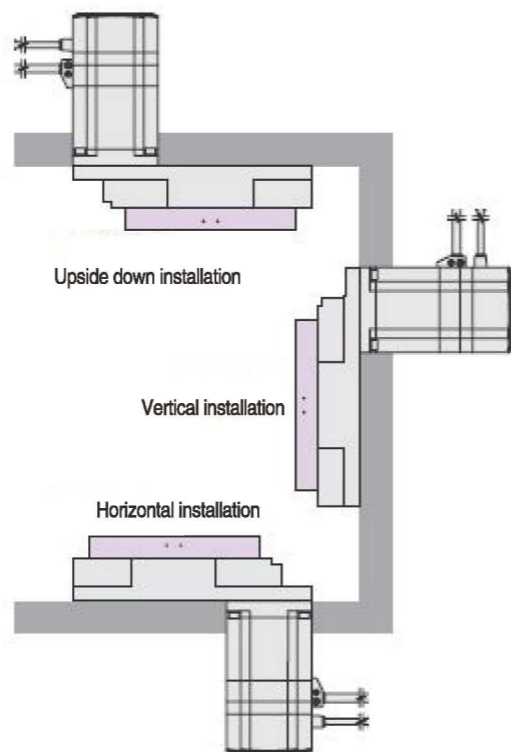

## Hollow rotary transmission device

- Direct connection→Simple design to improve trust

The hollow output platform can directly install the worktable and machine arm of the equipment. When the general equipment is positioned and run through the belt pulley and other parts, the precision of the transmission efficiency of the mechanism is reduced, or the necessity of maintaining the parts of the mechanism. The DG series can be directly installed because it does not pass through the intermediate parts, except that the accuracy of the product itself, it can also realize free-maintenance.

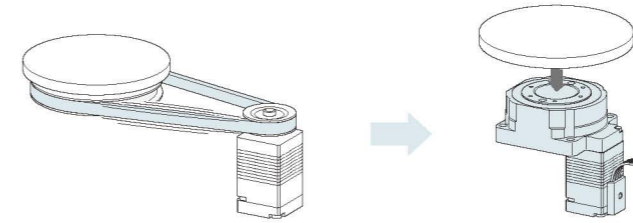

- Hollow rotary platform with large diameter→ simple wiring and piping

The design of a large diameter hollow hole (penetration) is realized by using one stage reduction gear mechanism to increase the diameter of the driven gear. It is suitable for the complicated wiring and piping application and so on, which makes the equipment design more succinct.

	Size(mm)	Hollow diameter
<b>DG60</b>	60	28
<b>DG85R</b>	85	33
<b>DG130R</b>	130	62

Eg: The application of DG130R.

## Structure drawing

- Standard type

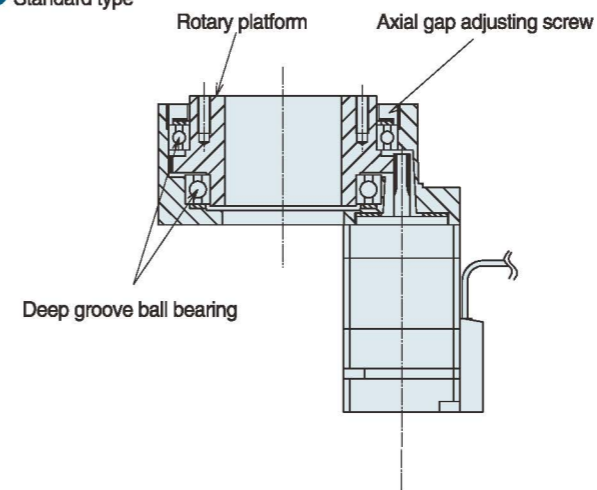

- Simple origin regression→ save time and labor for design and parts procurement.

In order to simplify the operation of the origin regression, the company also prepares the original sensor kit for customers(Choose and purchase accessories). The kit includes all the parts required to mark the original point. It can save the users' time and labor of installing the sensor for the design, production, and part purchase.

(DG130R sensor, example of shading plate installation )

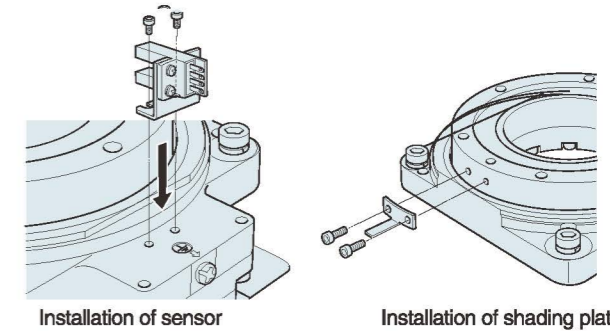

- High Positioning accuracy → repeated positioning accuracy is + 15sec Lost Motion is 2mins

The mechanism part have no backlash, because the gearbox adopts micro precision gear, and it can eliminate the backlash through its own adjusting mechanism. The repeated positioning accuracy of single direction is 15sec; while the lost motion is 2mins of two direction positioning, so it can achieve high precision positioning.

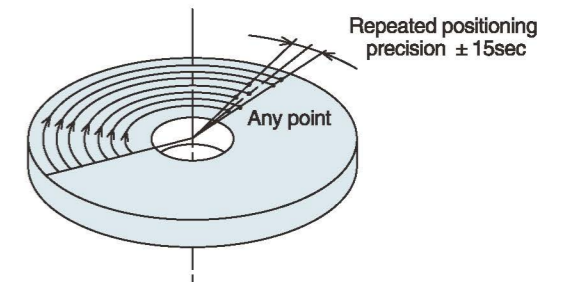

- High rigidity type (DG85R, DG130R)

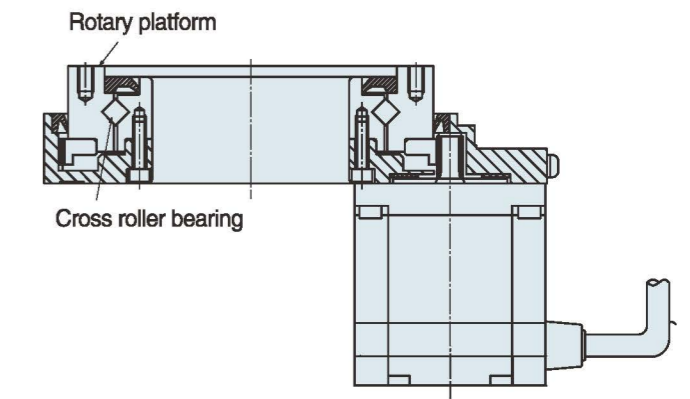

## Model Identification

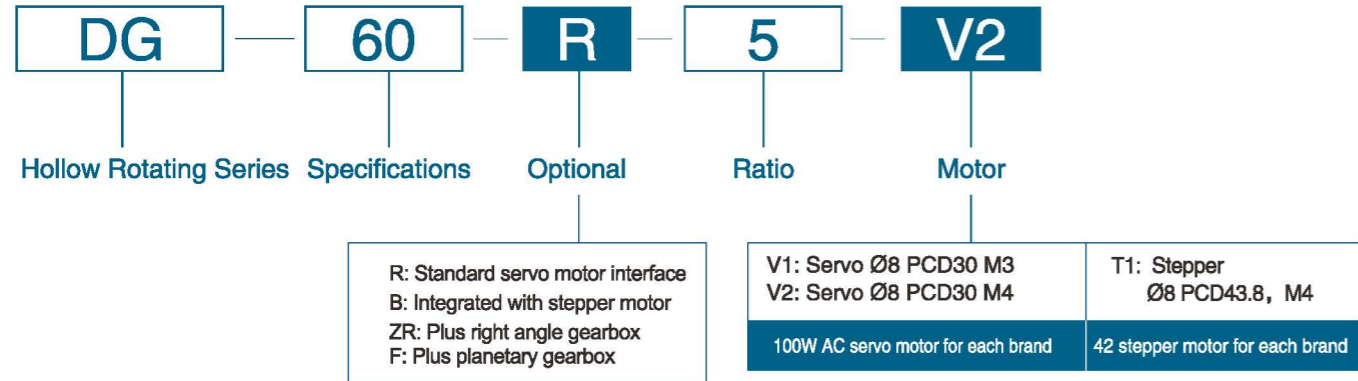

## Specification

Product model	Unit	DG060-R-5	DG060-B-10	DG060-ZR-15	DG060-F-10
Ratio		5	10	15	30/40/50
Matching servo motor	W	100	Stepper	100	400/100
Bearing structure		Crossed roller bearing	Crossed roller bearing	Crossed roller bearing	Crossed roller bearing
Allowable torque	N.M	5	5	5	5
Moment of inertia	kg.m <sup>2</sup>	4500 × 10 <sup>-7</sup>	4500 × 10 <sup>-7</sup>	4500 × 10 <sup>-7</sup>	21090 × 10 <sup>-7</sup>
Allowable plate output speed	r/min	200	200	200	200
Allowable inertia moment load	N.M	9	9	9	62/27
Allowable axial load	N	300	300	300	800
Repeat positioning accuracy	arc-sec	±5	±5	±5	±5
Positioning accuracy	arc-min	±0.5	±0.5	±0.5	≥3
Rotating platform surface deviation (plane bounce)	mm	±0.005	±0.005	±0.005	±0.005
Rotating platform concentricity	mm	±0.01	±0.01	±0.01	±0.01
Rotating platform parallelism	mm	±0.015	±0.015	±0.015	±0.015
Accuracy life	h	25000	25000	25000	25000
Protection class		IP40	IP40	IP40	IP40
Mass	kg	0.55	1.04	1	1.23

\* The above technical parameters are for reference only, and the actual specs and dimensions are issued according to the data provided by customers.

## Dimensions Unit: mm

### DG060-R-5

(A self assembled motor with a connecting seat)

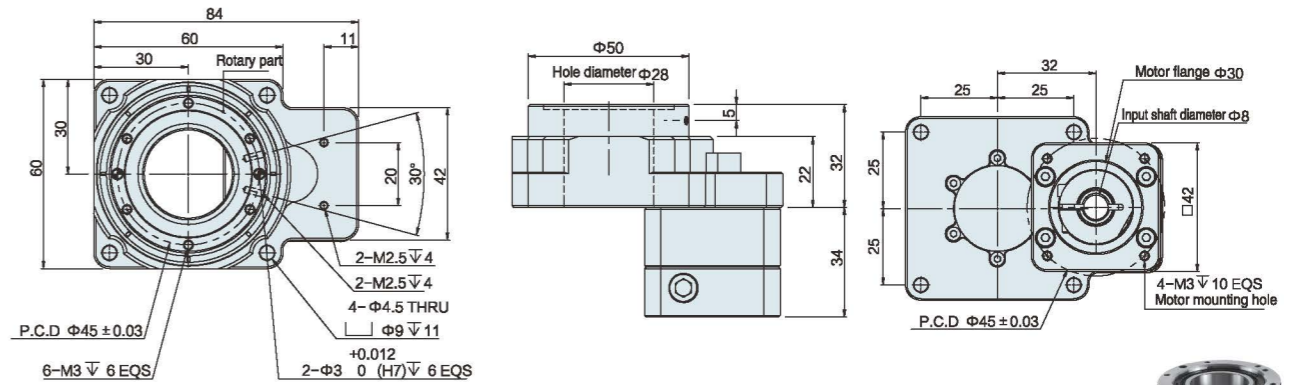

### DG060-B-10

(This model contains stepper motor 42H5K-2A)

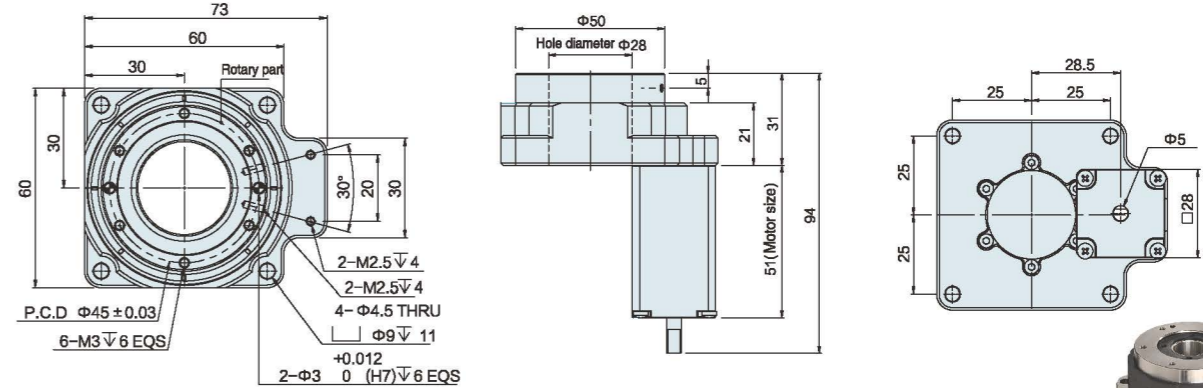

### DG060-ZR-15

(Right angle steering 1:15)

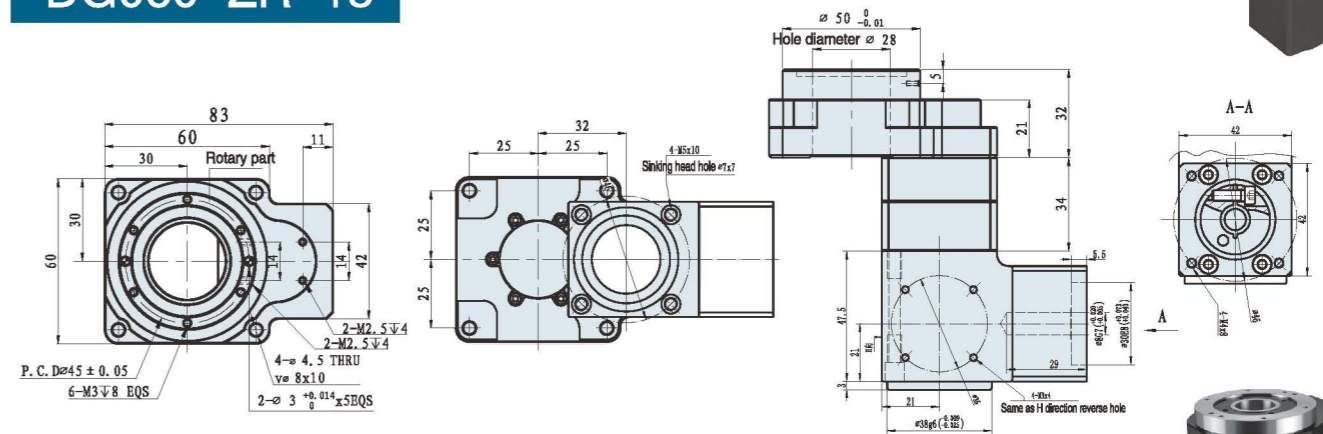
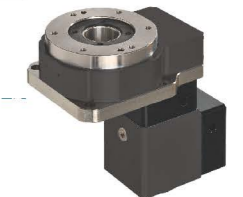

### DG060-F-10

(Attached planetary reducer ratio 30,40,50)

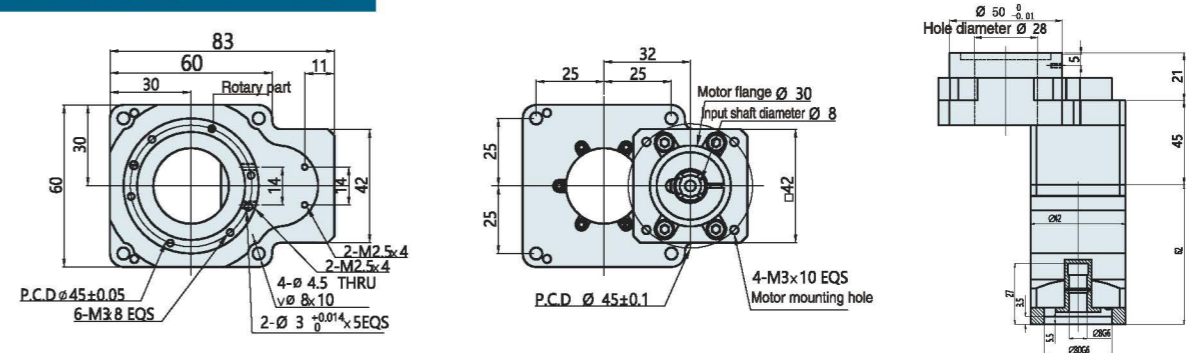

# Model Identification

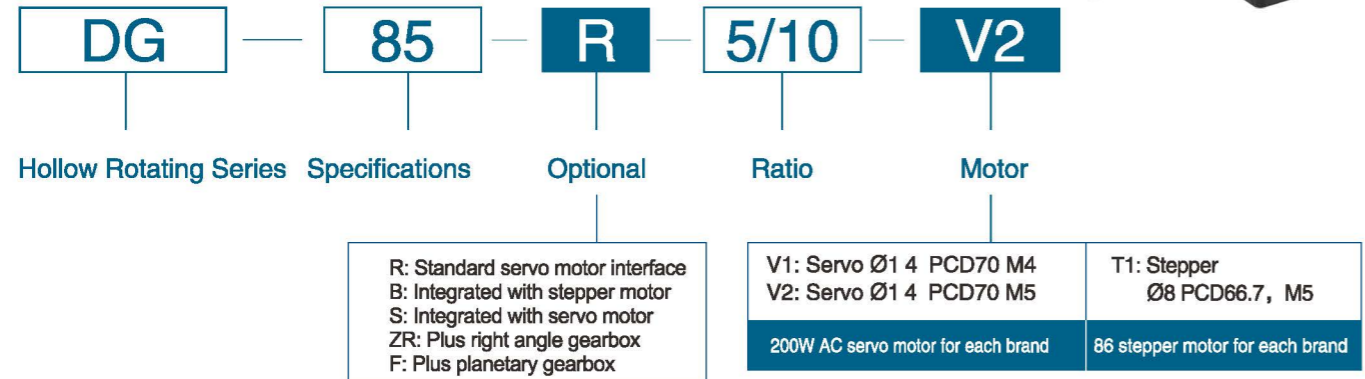

# Specification

Product model	Unit	DG085-R-5	DG085-B-10	DG085-S-10	DG085-ZR-10	DG085-F-10
Ratio		5/10	10	10	20/30	30/40/50
Matching servo motor	W	400/100	400/100	400/100	400/100	400/100
Bearing structure		Crossed roller bearing	Crossed roller bearing	Crossed roller bearing	Crossed roller bearing	Crossed roller bearing
Allowable torque	N.M	40/18	40/18	40/18	40/18	40/18
Moment of inertia	kg.m <sup>2</sup>	21090 × 10 <sup>-7</sup>	21090 × 10 <sup>-7</sup>	21090 × 10 <sup>-7</sup>	21090 × 10 <sup>-7</sup>	21090 × 10 <sup>-7</sup>
Allowable plate output speed	r/min	200	200	200	200	200
Allowable inertia moment load	N.M	62/27	62/27	62/27	62/27	62/27
Allowable axial load	N	800	800	800	800	800
Repeat positioning accuracy	arc-sec	± 5	± 5	± 5	± 5	± 5
Positioning accuracy	arc-min	± 0.5	± 0.5	± 0.5	≥ 3	≥ 3
Rotating platform surface deviation (plane bounce)	mm	± 0.005	± 0.005	± 0.005	± 0.005	± 0.005
Rotating platform concentricity	mm	± 0.01	± 0.01	± 0.01	± 0.01	± 0.01
Rotating platform parallelism	mm	± 0.015	± 0.015	± 0.015	± 0.015	± 0.015
Accuracy life	h	25000	25000	25000	25000	25000
Protection class		IP40	IP40	IP40	IP40	IP40
Mass	kg	1.15	1.85	2.1	2.05	2.1

\* The above technical parameters are for reference only, and the actual specs and dimensions are issued according to the data provided by customers.

# Dimensions Unit: mm

## DG085-R-(5/10) (A self assembled motor with a connecting seat)

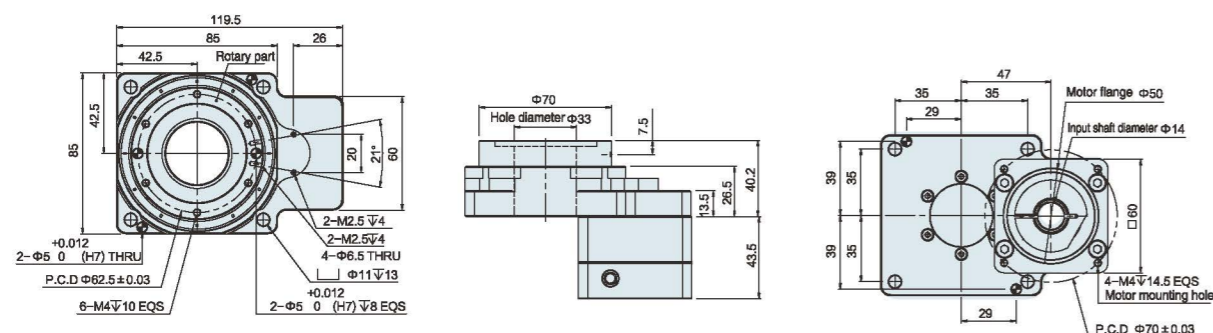

## DG085-B-10 (This model contains stepper motor 57H5K-2A)

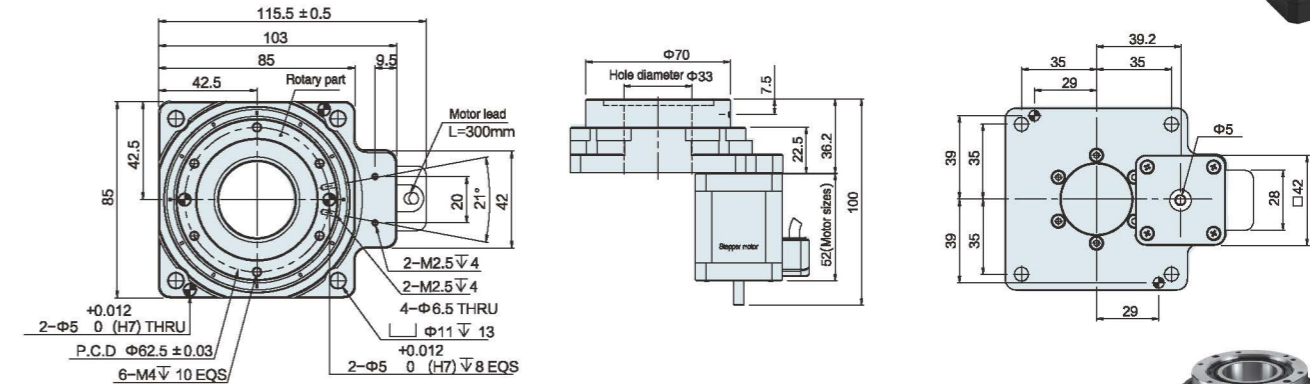

## DG085-S-10 (200W This model contains Servo motor)

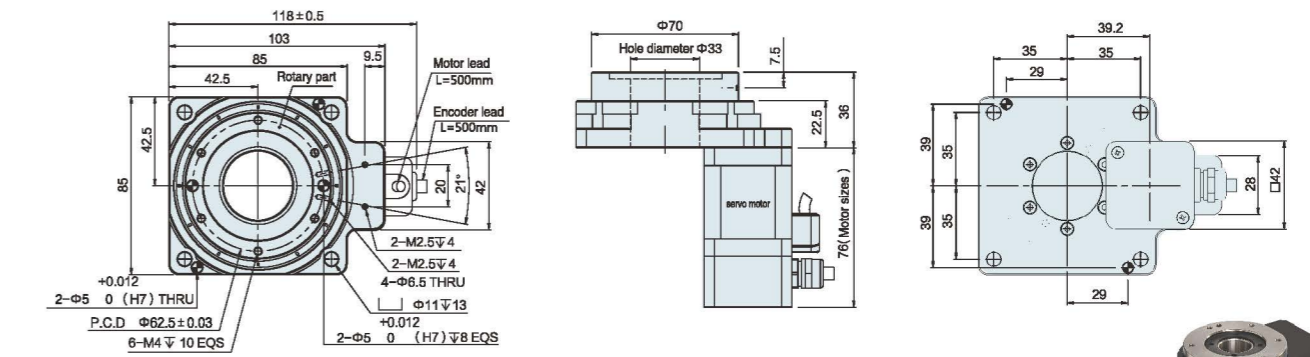

## DG085-ZR-10 (Right angle steering 20:30)

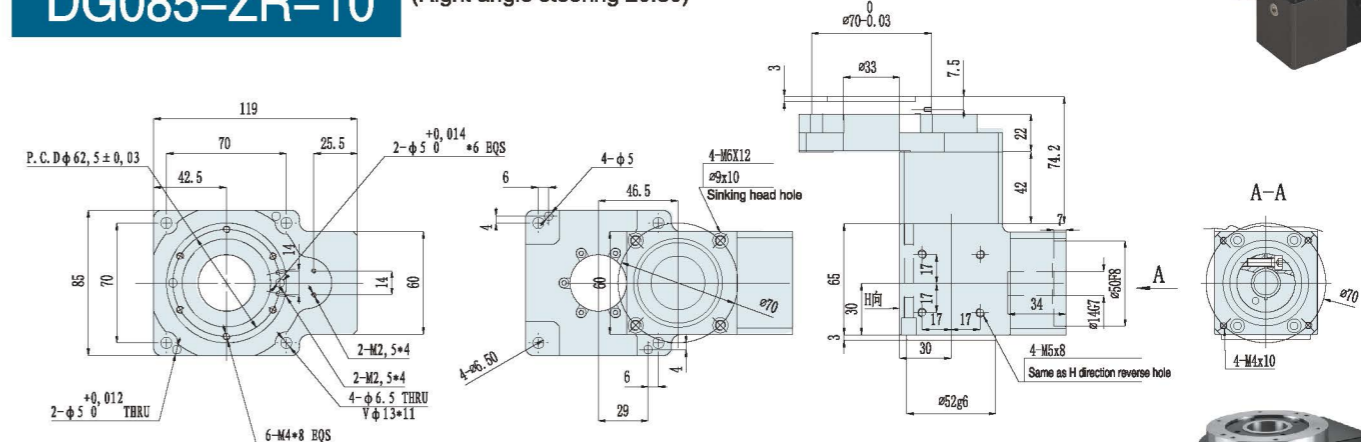

## DG085-F-10 (Attached planetary reducer ratio 30,40,50)

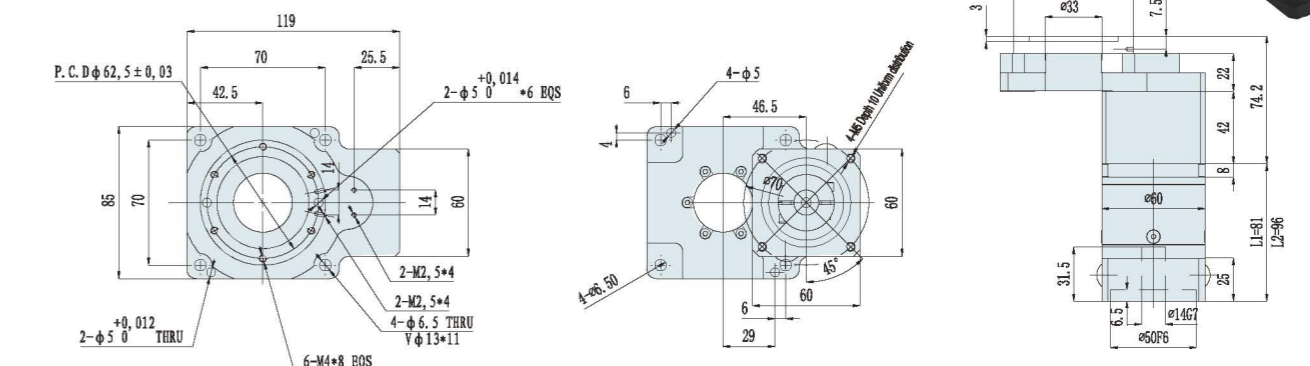





## Model Identification

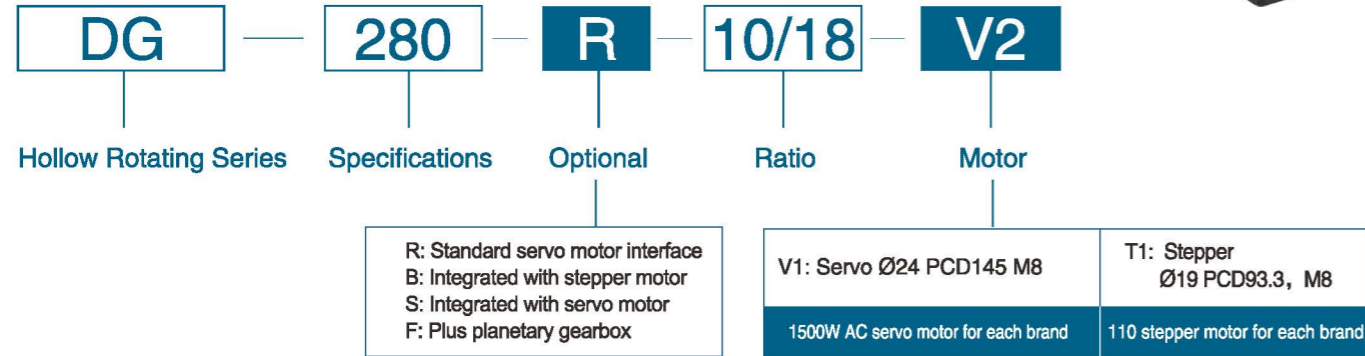

## Specification

Motor Model	110 Stepping Motor	1500W AC Servo Motor
Bearings of Rotating table	Crossed Roller Bearing	
Ratio	1:10 / 1:18	
Max.Torque	180Nm	180Nm
Moment of Inertia	146000*10 <sup>-6</sup> kg.m <sup>2</sup>	146000*10 <sup>-6</sup> kg.m <sup>2</sup>
Max.Speed	200r/min	200r/min
Max.Load of Inertia	216Nm	216Nm
Max.Axial Force	7000Nm	7000Nm
Positioning Accuracy	0.5arcmin	0.5arcmin
Repeatability	5arcsec	5arcsec
Table Play Eccentricity	0.005mm	0.005mm
Parallelism of rotating table	0.015mm	0.015mm
Concentricity of rotating table	0.01mm	0.01mm
Life	20000	20000
Degree of Protection	IP40	IP40
Weight	21.5Kg	22.2Kg

\* All specifications, dimensions and design characteristics shown in this catalogue are subject to change without notice.

## Dimensions Unit: mm

### DG280-B-(10/18) (This model contains stepper motor 110H5K-2A)

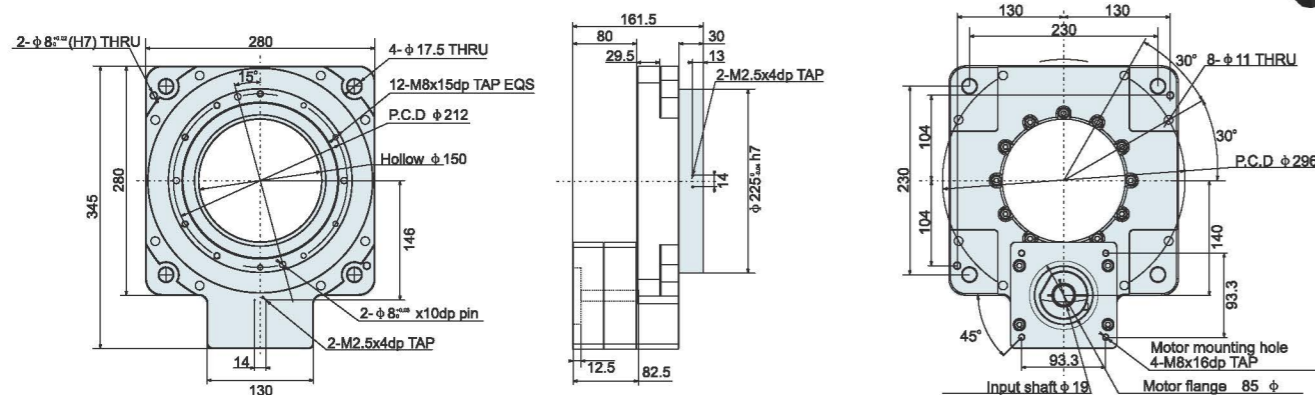
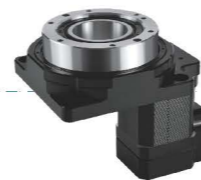

## Dimensions Unit: mm

### DG280-S-(10/18) (1500W This model contains Servo motor)

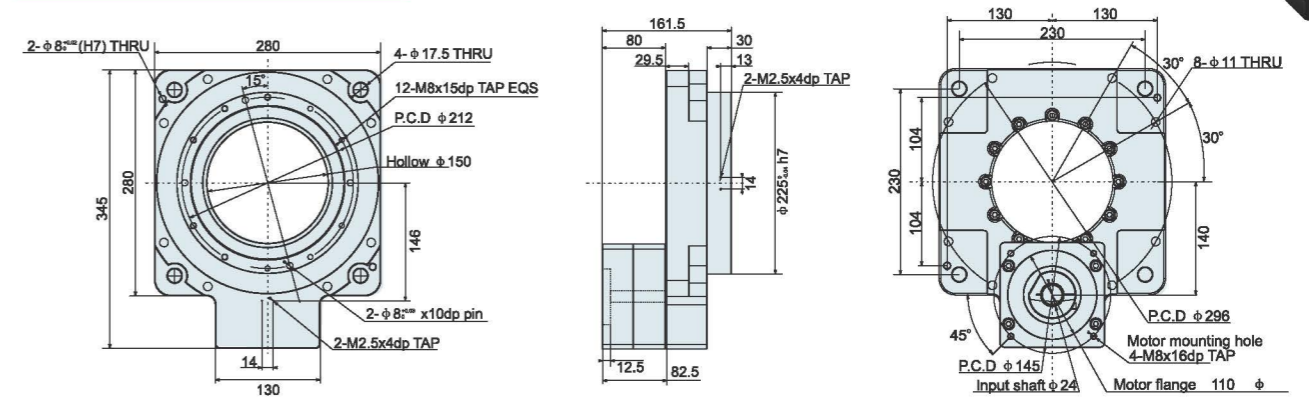

## Application Examples Technical Data

Description	i <sup>2</sup>	VRB115	
Nominal Output Torque T2N <sup>3</sup>	Nm	3	208
		4	290
		5	330
		7	300
		10	230
Emergency stop torque T2Not	Nm	2.5 times of Nominal Output Torque	
Nominal Input Speed	rpm	4000	
Max. Input speed	rpm	8000	
Backlash	Nm	≤3	
Torsional Stiffness	Nm/arcmin	25	
Max. Radial Force <sup>4</sup>	N	6700	
Max. Axial Force <sup>4</sup>	N	3350	
Service Life	Hr	20000(Continuous operation reduces service life 50%)	
Efficiency	%	96%	
Operating Temp	°C	-15°C ~ +90°C	
Degree of Protection		IP 65	
Lubrication		Synthetic Lubricating Grease	
Noise	dB(A)	≤63	

### DG280-S-30

(Attached planetary reducer ratio 30、40、50)

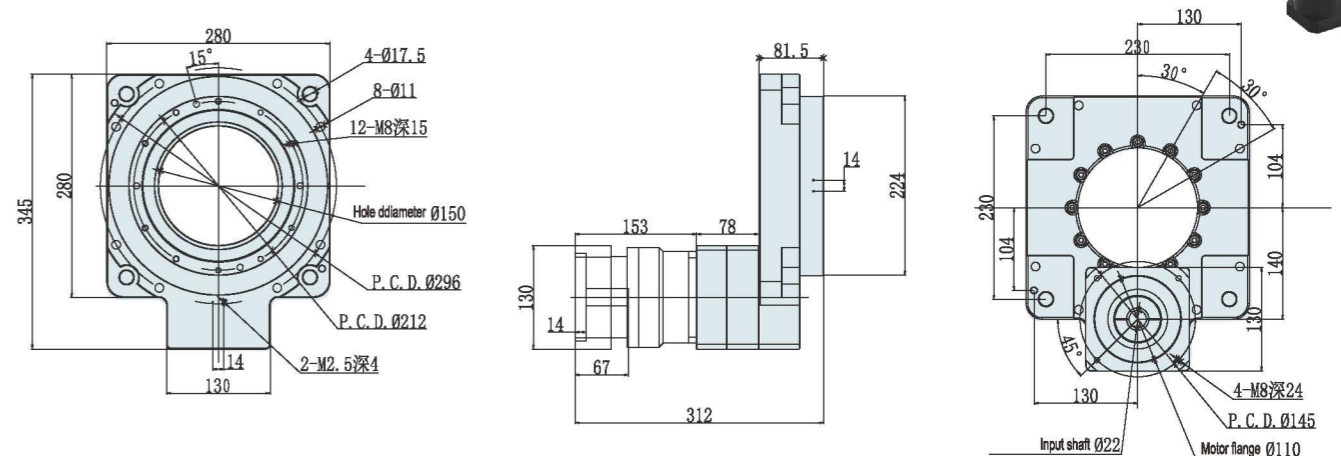

# Model Identification

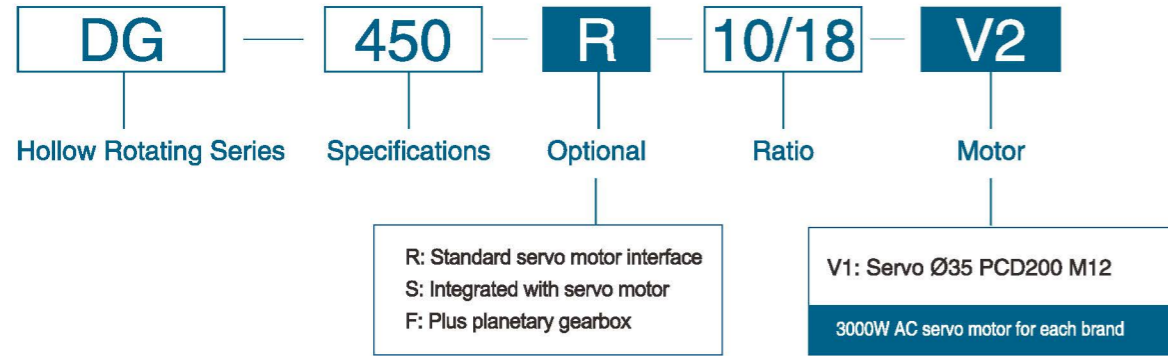

# Specification

Motor Model	3KW AC Servo Motor
Bearings of Rotating table	Crossed Roller Bearing
Ratio	1:10
Max.Torque	387Nm
Moment of Inertia	380230*10 <sup>-6</sup> kg.m <sup>2</sup>
Max.Speed	200r/min
Max.Load of Inertia	767Nm
Max.Axial Force	7000Nm
Positioning Accuracy	0.5arcmin
Repeatability	5arcsec
Table Play Eccentricity	0.005mm
Parallelism of rotating table	0.015mm
Concentricity of rotating table	0.01mm
Life	20000
Degree of Protection	IP40
Weight	80Kg

\* All specifications, dimensions and design characteristics shown in this catalogue are subject to change without notice.

# Dimensions Unit: mm

**DG450-S-(1/10)** (3000W This model contains Servo motor)

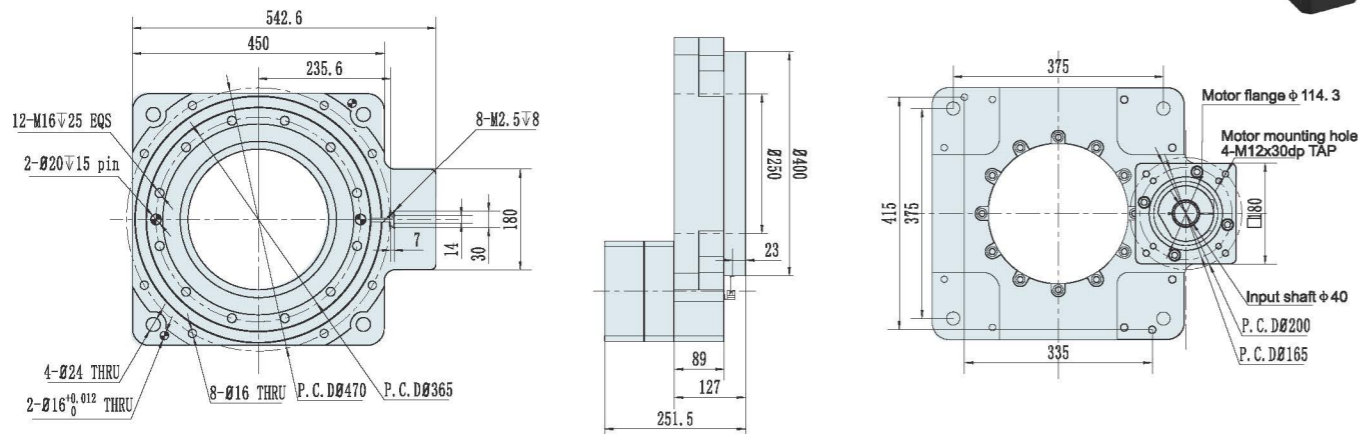

# Application Examples Technical Data

Description	i <sup>2</sup>	VRB142	
Nominal Output Torque T2N <sup>3</sup>	Nm	3	342
		4	540
		5	650
		7	550
		10	450
Emergency stop torque T2Not	Nm	2.5 times of Nominal Output Torque	
Nominal Input Speed	rpm	3000	
Max. Input speed	rpm	6000	
Backlash	Nm	≤3	
Torsional Stiffness	Nm/arcmin	50	
Max. Radial Force <sup>4</sup>	N	9400	
Max. Axial Force <sup>4</sup>	N	4000	
Service Life	Hr	20000(Continuous operation reduces service life 50%)	
Efficiency	%	96%	
Operating Temp	°C	-15°C ~ +90°C	
Degree of Protection		IP 65	
Lubrication		Synthetic Lubricating Grease	
Noise	dB(A)	≤65	

# DG450-S-30

(Attached planetary reducer ratio 30、40、50)

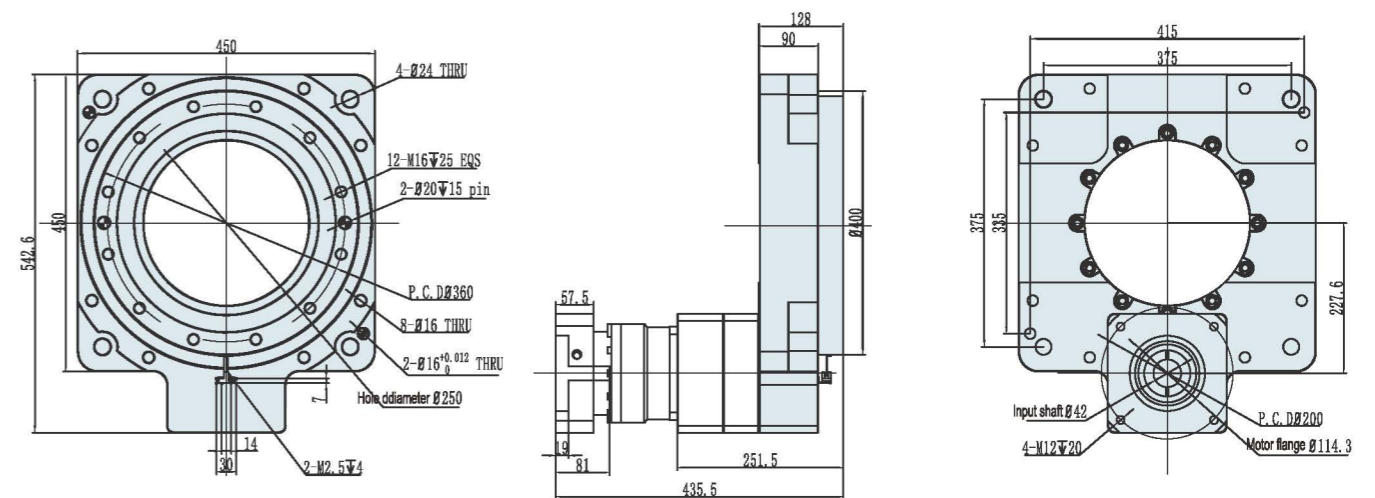

# Safety Precautions

## Cautions for storage

Whenever temporarily keeping the product, keep the following directions:

1. Keep in a clean and dry place.
2. Whenever storing outdoors or in a humid place, put in a box so that it does not directly contact rain or external air and cover with a vinyl sheet (Take a measure to prevent rust.)

## Cautions for operation

When the reducer is delivered to you.....

When the product delivered, please confirm that you received the exact same model you have ordered.

Please wipe out the input and output shaft of the reducer which is covered by anti-corrosive oil.

※Please remove the rubber cap on the input shaft before you wipe the shafts.

※Lubricant(grease) is already filled in the reducer. It is available as it is.

## Fixation & installation

Avoid use in a place where rain or water drops directly.

In case of use outdoors or in a place where dust and water drops, consult in advance.

Install at 0°C~40°C of surrounding temperature.

In case of use at temperature out of the above-mentioned range, contact the headquarters and consult on this.

Firmly fix with a bolt onto a solid stand without vibration.

Install in consideration of convenience in repair and inspection.

## Cautions prior to starting the operation

Reducer can be used soon after arrival, since it has already been filled out with lubrication.

At initial operation, check the rotating direction of the output shaft and then gradually apply load.

## Cautions during operation

Avoid overload. Ensure that input speed shall not be the number of revolutions beyond the specification.

In the following cases, stop the operation and check the following points:

- If temperature sharply increases
- If an abnormal noise appears sharply
- If the number of revolutions becomes unstable sharply

## Regulations

The scope of warranty only includes the product.

The following costs and damages are not covered by the warranty.

- 1) Shipping cost of this product.
- 2) The cost of removing, installing or other incidental construction of the product from other devices after connection or installation.
- 3) Due to the failure of this product, indirect damage caused to the user due to loss of use opportunities or business interruption.
- 4) All other derived or consequential damages.

# Installation

## Mounting procedure to the motor

- 1 Wipe off anti-rust agent and oil on the motor shaft.



- 2 Remove the plug

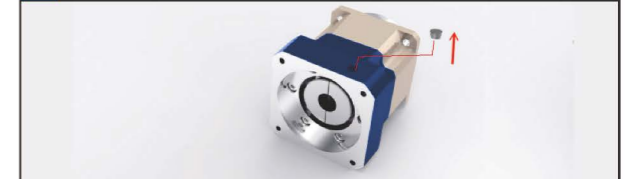

- 3 In case the bushing has been attached, Please fix it to the reducer as the drawing below.

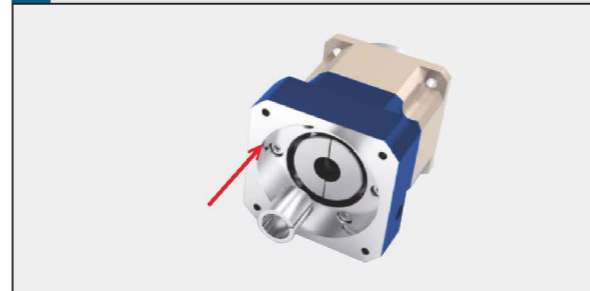

- 4 Please place reducer vertically on the flat surface so the motor mounting part faces up. Carefully insert the motor shaft into the input shaft. (It should be inserted smoothly) Make sure the motor flange is perfectly fit to the reducer's flange. Tighten the motor installing bolts to the proper torque.(See table1)

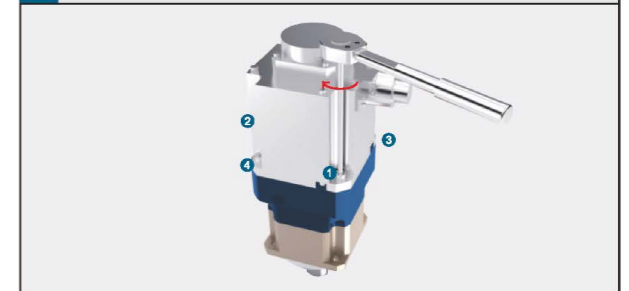

- 5 Tighten the clamping bolt of the input shaft with torque wrench to the proper torque.(See table1)

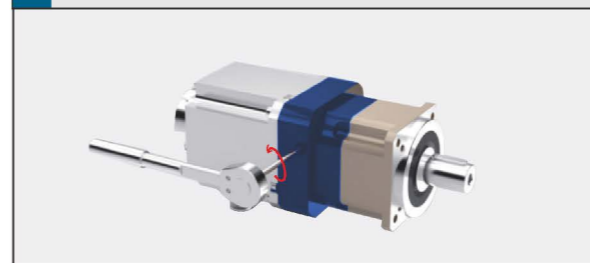

- 6 Reinstall the plug. The procedure is done.

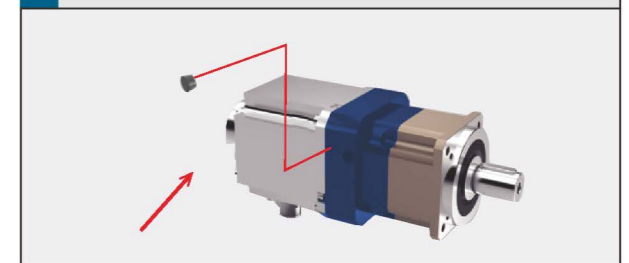

Table 1

Bolt size	Clamping bolt			
	Nm	kgfm	Nm	kgfm
M3	1.1	0.11	1.9	0.18
M4	2.5	0.26	4.3	0.44
M5	5.1	0.52	8.7	0.89
M6	8.7	0.89	15	1.5
M8	21	2.1	36	3.7
M10	42	4.3	71	7.2
M12	72	7.3	125	13
M16	134	14	-	-

Table 2

Bolt size	Tightening torque	
	Nm	kgfm
M3	1.9	0.18
M4	4.3	0.44
M5	8.7	0.89
M6	15	1.5
M8	36	3.7
M10	71	7.2
M12	125	13
M16	310	32
M20	603	62

※Recommended bolt: Strength 12.9